UniCel DxI

Access Immunoassay System

Access 2
IMMUNOASSAY SYSTEM

LIS Vendor Information

C03112-AF
May 2026



© 2026 Beckman Coulter, Inc. All rights reserved.
BECKMAN COULTER, INC. • 250 S. Kraemer Blvd. • BREA, CA 92821 • U.S.A.

Publication Notes

Beckman Coulter, Inc. grants a limited non-exclusive license to the UniCel DxI system or Access 2 system owner or operator to make a copy of all or a portion of this book solely for laboratory use.

Beckman Coulter, the stylized logo, and the Beckman Coulter product and service marks mentioned herein are trademarks or registered trademarks of Beckman Coulter, Inc. in the United States and other countries.

Remisol is a trademark of Normand-Info SAS.

MeMed BV and BV are registered trademarks of MeMed in the United States and other countries. Used under license.

Table of Contents

Preface	1
1 Overview	2
2 Low Level Transfer Protocol	5
3 Message Format	14
4 Sample Messages	38
Appendix A: ASCII Character Codes	45
Appendix B: Test Codes Used by the Instrument	51
Appendix C: Japanese and Simplified Chinese Characters ..	59
Appendix D: EIA-232 Cables, Connectors, and Adapters . . .	60

Preface

This document is intended as a guide to laboratory information system (LIS) vendors developing interfaces that communicate with the UniCel DxI Access Immunoassay System or the Access 2 Immunoassay System. In this document, the term, instrument, refers to either of these systems, except where noted. **Provide this document to your LIS vendor prior to interfacing the instrument and the laboratory computer.**

NOTES

- The protocols in this document are not applicable to Access 2 Immunoassay Systems that are parts of UniCel DxC 600i Synchron Access Clinical Systems.
- The protocols in this document are not applicable to UniCel DxI Access Immunoassay Systems that are parts of UniCel DxC Synchron Access Clinical System Integrated Workstations.

The LIS interface is based on the following ASTM standard protocols:

- ASTM E1394-97
- ASTM E1381-95

Changes to this Revision

Revision AF of this document includes the following change(s):

- Updated test list in Appendix B: Test Codes Used by the Instrument:
 - Added Access codes BV-Score, NTBPN, and TT4II
-

1 Overview

The LIS feature of the instrument software allows a laboratory computer to communicate with the instrument through a standard serial connection. The LIS interface specification consists of two major functional groups:

- Low level transfer protocol
- Message format definitions

The low level transfer protocol specified by ASTM E1381 includes the methods of physical interconnection of devices, characteristics and format of data, and methods of opening and closing communications sessions.

The message format definitions specified by ASTM E1394 define the format of the data records to be passed between the instrument and the laboratory computer. Message data is sent in delimited records, of which there are seven types. For information on the record types and their contents, see Record Field Descriptions on page 16.

Definitions of Terms

The following list defines terms as they are used in this document.

<ACK>	acknowledge (ASCII Decimal 6).
<CR>	carriage return (ASCII decimal 13).
<ENQ>	enquiry (ASCII Decimal 5).
<EOT>	end of transmission (ASCII decimal 4).
<ETB>	end of transmission block (ASCII Decimal 23). For use only when a single record is too large to fit into one frame.
<ETX>	end of text (ASCII Decimal 3). Required at the end of each record.
<LF>	line feed (ASCII Decimal 10).

<NAK>	negative acknowledge (ASCII Decimal 21).
<STX>	start of text (ASCII Decimal 2).
[C1]	The most significant hexadecimal digit of the checksum, expressed as an ASCII character.
[C2]	The least significant hexadecimal digit of the checksum, expressed as an ASCII character.
[DATA]	The data contents of the record.
[frame#]	An ASCII numeric character ranging from 0 to 7 . Frame numbers begin at 1 , and are incremented using modulo 8 arithmetic. When the frame number reaches 7 , the numbering starts over at 0 .
Communications Packet	All framing required for transmission of data. This framing includes: <STX> [frame#] [DATA] [<ETB> or <ETX>] [C1] [C2] <CR> <LF>.
Component Field	A single data element or data elements which express a finer aggregate or extension of data elements which precede it. For example, a field called Name may have component fields called Last, First, and Middle Initial. A component field may not include Repeat delimiters.
Download	The transmission of data from the laboratory computer to the instrument.
Field	A specific location within a record for a piece of information, indicated by a field delimiter and position.
Frame	A subdivision of a message, used to allow periodic communication housekeeping such as error checks and acknowledgement.
Instrument	The UniCel DxI Access Immunoassay System or the Access 2 Immunoassay System. Except as noted, both systems behave identically with respect to the LIS interface.
Laboratory Computer	A computer that has been set up to communicate with one or more laboratory instruments, using the ASTM E1394 and ASTM E1381 specifications.
LIS	Laboratory information system. Also see Laboratory Computer.
Message	A collection of related information, consisting of a group of records that begins with a Header record and ends with a Terminator record. A single record could theoretically constitute a message, but in this document, a message always contains multiple records. For more information, see Chapter 3 : Message Format.

Modulo <i>n</i>	<p>An integer arithmetic system in which all values are restricted to the range 0 to <i>n</i>-1. Any value outside of this range is brought into range by repeatedly adding or subtracting <i>n</i> until the number is in range.</p> <p>For example, in a modulo 8 system, the range is 0 to 7. A modulo 8 counter is incremented until it reaches 7, then starts over at 0. Likewise, the range for a modulo 256 system is 0 to 255.</p>
Receiver	<p>The system that responds to the sender and accepts the message. The receiver in this document is either the instrument or the laboratory computer.</p>
Record	<p>In the data link layer, a record is the message data (shown as [DATA]) described within the communications packet. If the data is longer than 240 characters, it must be split into two parts and sent in two communications packets. The intermediate packet uses the <ETB> character, and the ending packet uses the <ETX> character. No single communications packet contains more than one record.</p> <p>In the message layer, a record is an aggregate of fields describing one aspect of the complete message. A record contains one of the ASTM standard record codes. For more information, see Chapter 3 : Message Format.</p>
Repeat Field	<p>An additional field of the preceding type, indicated by the Repeat delimiter. Repeat fields are supported only for the Universal Test ID of a Test Order record, and the Nature of Abnormality Testing fields of a Test Result record. The instrument ignores other occurrences of repeat fields.</p>
Sender	<p>The system that has a message to send and initiates the transmission process between two devices. The sender in this document is either the instrument or the laboratory computer.</p>
Session	<p>A complete unit of communication activity consisting of the establishment phase, the transfer phase, and the termination phase. For more information, see Data Link Layer on page 6.</p>
Test	<p>A determination of a single analyte or a combination of values from other determinations or observations from which a variable or gradable result is derived.</p>
Test Order, or Test Request	<p>The sample and test information downloaded from the LIS, or manually entered by an operator on the Test Request screen.</p>
Upload	<p>The transmission of data from the instrument to the laboratory computer.</p>

2 Low Level Transfer Protocol

The low level transfer protocol, defined in ASTM E1381, consists of a physical layer and a data link layer:

- The physical layer is the EIA-232 communications hardware
- The data link layer defines the format of the serial data

The data link layer is responsible for establishing a connection between the sender and receiver, initiating the transfer of data frames, and termination of the connection. In the LIS interface specification, the data link layer also handles error checking through the use of checksum characters.

Physical Layer

All communications are expected to use the EIA-232 asynchronous serial communication protocol, based on the Electronics Industries Association (EIA) standard EIA-232-D. The instrument is configured as Data Terminal Equipment (DTE).

The instrument is connected to the laboratory computer using a DB-9 male connector on the back of the instrument external PC. Because most computer ports are configured for DTE operation, a null modem cable is typically required for connecting the laboratory computer to the instrument. For details about the pin assignments for the instrument LIS port, and the signals that must be provided on the corresponding pins of the laboratory computer cable, see Appendix D: EIA-232 Cables, Connectors, and Adapters.

The instrument serial interface is configured for 1 start bit, 8 data bits, no parity bit, and 1 stop bit. This configuration is fixed in accordance with ASTM standard E1381, and cannot be changed. The baud rate is set by default to 9600, but the interface can be configured for 1200, 2400, 4800, 9600, 14400, or 19200 baud operation.

Data Link Layer

The data link layer includes procedures for link connection and release, delimiting and synchronism, sequential control, error detection, and error recovery as specified in ASTM E1381 (Section 6, Data Link Layer). There are three distinct phases in transferring information between the instrument and the laboratory computer. These phases assure that the actions of the sender and receiver are coordinated. The three phases are establishment, transfer, and termination. Together, these three phases constitute a session.

The data link layer uses a character-based protocol to send messages between directly connected systems. The data link mode of operation is one-way transfer of information with alternate supervision. Information flows in one direction at a time. Replies occur after information is sent, never at the same time. It is a simplex stop-and-wait protocol. At times the two systems are actively operating to transfer information. The remainder of the time the data link is in a neutral state.

Establishment Phase

The establishment phase determines the direction of information flow and prepares the receiver to accept information. A system which does not have information to send normally monitors the data link to detect the establishment phase. It acts as a receiver, waiting for the other system to initiate a message exchange.

The system with information to send initiates the establishment phase. After the sender determines that the data link is in a neutral state, it transmits the <ENQ> transmission control character. The receiver ignores any character other than <ENQ> while in the neutral state. The sender ignores any response to <ENQ> other than <ACK>, <NAK>, or <ENQ>.

Table 2-1 Establishment Phase

Receiver State When <ENQ> is Received	Receiver Reply	Sender Action After Receiving Reply
Ready	<ACK>	Go to transfer phase.
Not Ready	<NAK>	Wait 10 seconds, then send <ENQ> again.
Already Sending	<ENQ>	Line contention condition. Receiver also has information available and has sent <ENQ> before recognizing the Sender request. If Sender is the instrument, wait 1 second, then send <ENQ> again. If Sender is the laboratory computer, go to neutral state for 20 seconds, or until a complete message has been received from the instrument.

Transfer Phase

During the transfer phase, the sender transmits records to the receiver. The transfer phase continues until all records are sent. Records are sent in frames. Each frame contains a maximum of 247 characters, including seven characters of frame overhead. Records with content of more than 240 characters are divided between two or more frames. Multiple records cannot be combined in a single frame. Every record must begin in a new frame.

There are two types of frames: intermediate and end. Intermediate frames terminate with the characters <ETB> [C1] [C2] <CR> <LF>. End frames terminate with the characters <ETX> [C1] [C2] <CR> <LF>. A record containing 240 characters or less is sent in a single end frame. Longer records are sent in intermediate frames with the last part of the record sent in the end frame. A complete record frame has the following format:

```
<STX> [frame#] [DATA] <ETX> [C1] [C2] <CR> <LF>
```

(The example shows a single, or end frame. An intermediate frame has <ETB> after the [DATA], instead of <ETX>.)

Frame Number

The frame number permits the receiver to distinguish between new and retransmitted frames. It is sent immediately after the <STX> character.

The frame number is an ASCII numeric character ranging from 0 to 7. Frame numbers begin at 1 with the first frame of the transfer phase, and are incremented, using modulo 8 arithmetic, for each new frame transmitted. When the frame number reaches 7, the numbering starts over at 0.

The system expects the frame number to fit one of the following conditions:

- [frame#] = 1 for the first frame in a transfer phase
- [frame#] = [previous frame#] + 1 (modulo 8) for successive frames after the first frame
- [frame#] = [previous frame#] for a retransmitted frame

If the frame number does not fit one of these conditions, the frame is considered defective.

Checksum

The checksum permits the receiver to detect a frame that is defective due to a transmission error. It is encoded as two characters, which are sent after the <ETB> or <ETX> character. The checksum is computed by adding the binary values of [frame#], the [DATA] characters, and the <ETB> or <ETX> character, keeping only the least significant eight bits (modulo 256 arithmetic).

The 8-bit checksum is expressed in hexadecimal by two ASCII characters, [C1] and [C2], of the range [0-9, A-F]. [C1] represents the most significant four bits of the checksum, and [C2] represents the least significant four bits.

Acknowledgement

The receiver must acknowledge the receipt of each frame before the sender can transmit the next frame. The receiver acknowledges a frame by sending one of three characters:

- <ACK> signifies that the frame was received successfully and that the receiver is ready to receive another frame.
- <NAK> signifies that the frame was not received successfully, and that the receiver is ready to receive that frame again
- <EOT> signifies that the frame was received successfully and that the receiver is ready to receive another frame. It is also a request for the sender to stop transmitting.

The acknowledgement must be transmitted within the time-out period. (For more information, see Time-outs on page 9).

Receiver Interrupts

The receiver interrupt is an <EOT> acknowledgement that requests that the sender stop transmitting messages as soon as possible. If the sender ignores the <EOT> and continues transmitting, the receiver must request the interrupt again after receiving the next frame.

When the sender honors the interrupt request, it must enter the termination phase. This gives the receiver an opportunity to enter the establishment phase and become the sender. The original sender must not enter the establishment phase for at least 15 seconds or until the receiver has sent a message and returned the data link to the neutral state.

Defective Frames

The receiver checks each frame for validity. A reply of <NAK> is transmitted for invalid frames. The receiver ignores any characters occurring before the <STX> or <EOT>, or after the end of block character <ETB> or <ETX> when checking the frame. A frame is rejected when:

- Any character framing errors are detected
- The frame checksum does not match the checksum computed on the received frame
- The frame number is not the same as the last accepted frame (or one number higher, modulo 8)

Upon receiving a <NAK> or any character other than <ACK> or <EOT>, the sender increments a retransmit counter and retransmits the frame with the same frame number. If a single frame is sent six times without being accepted, the sender must stop transmitting this message and enter the termination phase. This should be extremely rare, but it provides a mechanism to escape from a condition where the transfer phase cannot continue.

Termination Phase

The termination phase returns the data link to the neutral state. The sender transmits the <EOT> transmission control character to notify the receiver that no more records will be sent and that the data link has been returned to the neutral state. Upon receiving <EOT> the receiver also regards the data link to be in a neutral state.

Time-outs

The sender and receiver both use timers to detect loss of coordination between them. The following conditions are resolved by time-outs:

No Reply During the Establishment Phase

If, after sending an <ENQ> to establish a connection, a reply of an <ACK>, <NAK> or <ENQ> is not received within 15 seconds, a time-out occurs. After a time-out, the sender enters the termination phase.

Contention During the Establishment Phase

During the establishment phase, if the laboratory computer detects contention, it sets a timer, goes to the neutral state, and waits for an <ENQ> from the instrument. If an <ENQ> is not received from the instrument within 20 seconds, a time-out occurs and the laboratory computer may make another attempt to establish a link as sender.

If the instrument detects contention during the establishment phase, it waits one second, then sends another <ENQ>.

During the Transfer Phase

During the transfer phase, the sender sets a timer when transmitting the last character of a frame. If a reply is not received within 15 seconds, a time-out occurs. After a time-out, the sender cancels the message transfer and enters the termination phase. As with excessive retransmissions of defective frames, the message must be remembered so that it can be completely repeated.

NOTE

Receivers that cannot process messages fast enough to keep up with a sender may cause message buffer overflows in the sender. A sender can normally store at least one complete message. Storage for more than one outgoing message is desirable but optional.

Receiver Waiting for Frame

During the transfer phase, the receiver sets a timer when first entering the transfer phase or when replying to a frame. If a frame or <EOT> is not received within 30 seconds, a time-out occurs. After a time-out, the receiver discards the last incomplete message and regards the line to be in the neutral state.

Restricted Characters

The low-level transfer protocol is designed for sending character based message text. Restrictions are placed on which characters can be used in the message text. The restrictions make it simpler for senders and receivers to recognize replies and frame delimiters. Additional characters are restricted to avoid interfering with software controls for devices such as multiplexers.

The <LF> character is not permitted in the [DATA] portion of the message text, and must only be used as the last character of a frame. The following characters are restricted, and must not appear in the [DATA] portion of the message frame: <SOH>, <STX>, <ETX>, <EOT>, <ENQ>, <ACK>, <DLE>, <NAK>, <SYN>, <ETB>, <LF>, <DC1>, <DC2>, <DC3>, and <DC4>.

Data Link Layer Sequence

The following examples illustrate data link layer sequences:

Normal Session	Sender	Receiver
Establishment Phase	<ENQ> → ←	<ACK>
Transfer Phase	<STX> [frame#] [DATA] <ETX> [C1] [C2] <CR> <LF> → ← (Frames continue until entire message is sent)	<ACK>
Termination Phase	<EOT> →	No response expected

Delay Request Session (<NAK>)	Sender	Receiver
Establishment Phase	<ENQ> → ← (Delay 10 seconds) <ENQ> → ←	<NAK> <ACK>
Transfer Phase	<STX> [frame#] [DATA] <ETX> [C1] [C2] <CR> <LF> → ← (Frames continue until entire message is sent)	<ACK>
Termination Phase	<EOT> →	No response expected

Failure Session (No Response)	Sender	Receiver
Establishment Phase	<ENQ> → (Time-out after 20 seconds)	No response
Termination Phase	<EOT> →	No Response expected

Retransmission Request (Less than Six <NAK>s)	Sender	Receiver
Establishment Phase	<ENQ> →	<ACK>
Transfer Phase	<STX> [frame#] [DATA] <ETX> [C1] [C2] <CR> <LF> →	<NAK>
	<STX> [frame#] [DATA] <ETX> [C1] [C2] <CR> <LF> →	<NAK>
	<STX> [frame#] [DATA] <ETX> [C1] [C2] <CR> <LF> →	<NAK>
	<STX> [frame#] [DATA] <ETX> [C1] [C2] <CR> <LF> →	<ACK>
	(Frames continue until entire message is sent)	
Termination Phase	<EOT> →	No Response expected

Failure Session (Six <NAK>s)	Sender	Receiver
Establishment Phase	<ENQ> →	<NAK>
	(Delay 10 seconds) <ENQ> →	<NAK>
	(Delay 10 seconds) <ENQ> →	<NAK>
	(Delay 10 seconds) <ENQ> →	<NAK>
	(Delay 10 seconds) <ENQ> →	<NAK>
	(Delay 10 seconds) <ENQ> →	<NAK>
	(Delay 10 seconds)	
Termination Phase	<EOT> →	No Response expected

Failure Session (Receiver Timeout During Transfer)		Sender	Receiver
Establishment Phase		<ENQ>	→
			← <ACK>
Transfer Phase	<STX> [frame#] [DATA] <ETX> [C1] [C2] <CR> <LF>		→
			← No response within 15 seconds
Termination Phase		<EOT>	→
			No response expected

Failure Session (Sender Timeout During Transfer Phase)		Sender	Receiver
Establishment Phase		<ENQ>	→
			← <ACK>
Transfer Phase	<STX> [frame#] [DATA] <ETX> [C1] [C2] <CR> <LF>		→
			← <ACK>
Termination Phase	No frame sent within 30 seconds		
			Discards incomplete message and assumes neutral state

3 Message Format

The message format used by the LIS interface conforms to the ASTM standard E1394.

This section describes the record types, and the fields and delimiters that make up a record (shown as [DATA] in the low-level transfer protocol).

Record Content

The following topics identify the limitations and general considerations regarding record content. For the acceptable values for each field, see Record Field Descriptions on page 16.

NOTE

When instruments are configured for the Japanese or Chinese languages, additional considerations for record content apply. For information about using Japanese or Simplified Chinese characters, see Appendix C: Japanese and Simplified Chinese Characters.

Allowed Characters

The message data sent to the instrument must be restricted to ASCII characters 32-126 (the standard printable keyboard characters) for proper operation of the instrument software. Specific fields may further restrict allowed characters. Also see Appendix A: ASCII Character Codes.

Language

All transmissions to and from the instrument must be in English, even if the user interface is set to a language other than English.

Maximum Field and Record Length

While no maximum field length is imposed by the low level protocol, the parser restricts the length of fields to meet the maximum record length of 1024 characters. For individual field restrictions, see Record Field Descriptions on page 16.

Record Codes

The following codes are required for conformance to the ASTM standard:

H	Message Header record
P	Patient Information record
O	Test Order record
R	Result record
C	Comment record
S	Scientific record (not used by the instrument)
M	Manufacturer record (not used by the instrument)
Q	Request Information record
L	Message Terminator record

Delimiters

The Message Header record defines the unique field, repeat, component, and escape delimiters that are used in the message.

Care should be taken when assigning delimiters. Avoid using any character that is likely to be contained in the record text. The recommended delimiters are shown in Table 3-1. These delimiters are used in the examples throughout this document.

Table 3-1 Recommended Delimiters

Delimiter	Character	ASCII Code
Field		124
Repeat	\	92
Component	^	94
Escape	&	38

When a record field contains a character that is also defined as a delimiter, the character must be preceded and followed by the Escape delimiter to prevent the parser from interpreting the character as a delimiter.

Null Fields

Fields are identified by counting field delimiters from the beginning of the record. If no data is provided for a field (a null field), the field delimiter must be included to enable the parser to correctly identify subsequent fields. However, delimiters are not required for contiguous null fields at the end of a record. When the parser encounters the End of Record delimiter, any remaining fields are considered null. In this document, null refers to an empty field, and not to the ASCII character <NUL>.

The laboratory computer can be programmed to send a null field for 1) an unknown value, 2) a value that is ignored by the instrument, or 3) a value that matches the instrument default value.

Record Field Descriptions

The ASTM E1394 specification defines nine record types, of which seven are used by the instrument:

- Message Header record
- Patient Information record
- Test Order record
- Result record
- Comment record
- Manufacturer Information record (not used by the instrument)
- Scientific record (not used by the instrument)
- Request Information record
- Message Terminator record

The following topics describe the fields in each record type and give examples of complete messages of that type. For each record, a table shows the record identifier, the delimiters for each field or component, an example, and the maximum length of the field. The table also shows how the instrument supports that field when receiving and sending messages:

- **Required** - Mandatory field which must not be null. The instrument must include it when uploading messages, and will reject downloaded messages in which it is null.
- **Yes** - Supported, but optional. The instrument will store the data received in downloaded messages, and, if the data is available, will include it in uploaded messages.
- **Ignored** - Not supported in downloaded messages. The field will be accepted by the instrument, but not stored.
- **No** - Not supported for uploaded messages (not sent by the instrument).

Message Header Record

The Message Header record is the first record of every message. It contains overhead information such as sender and receiver IDs, and the date and time of the message, and defines the delimiters to be used for all records in the message.

Examples

Typical Uploaded Frame:

```
<STX>1H|\^&|||ACCESS^500001||||LIS||P|1|20111231235959<CR><ETX>20<CR><LF>
```

Typical Downloaded Frame:

```
<STX>1H|\^&|||LIS||||||P|1|20111231235959<CR><ETX>EA<CR><LF>
```

Minimal Downloaded Frame:

```
<STX>1H|\^&|<CR><ETX>61<CR><LF>
```

Table 3-2 Message Header Record Fields

Description	Delimiter	Example	Max. Length	Instrument Receive	Instrument Send
Record Identifier	H		1	Required	Required
Delimiters:					
Field			1	Required	Required
Repeat		\	1	Required	Required
Component		^	1	Required	Required
Escape		&	1	Required	Required
Message Control ID				Ignored	No
Instrument Password				Ignored	No
Sender Name or ID		ACCESS	40	Ignored	Yes
System ID	^	500001	40	Ignored	Yes
Sender Street Address				Ignored	No
Reserved Field				Ignored	No
Sender Telephone Number				Ignored	No
Characteristics of Sender				Ignored	No
Receiver ID		LIS	40	Yes	Yes
System ID	^		40	Yes	Yes
Comment or Special Instructions				Ignored	No

Table 3-2 Message Header Record Fields (continued)

Description	Delimiter	Example	Max. Length	Instrument Receive	Instrument Send
Processing ID		P	1	Yes	Yes
Version Number		1	12	Yes	Yes
Date and Time of Message		2011123123 5959	14	Yes	Yes
End of Record	<CR>		1	Required	Required

Descriptions of Supported Header Record Fields

Message Header Record Identifier

The Message Header record is identified by the letter **H** in the Record Identifier field. Case sensitive.

Delimiters

Defines the delimiters to be used in a message. Once defined, it is the responsibility of the sender to avoid including any of the delimiter characters within the field contents. The receiver will determine what characters to use by reading the delimiter specification it receives in each header record.

NOTE

Do not use the /, -, or * characters as delimiters. If they are defined as delimiters, the system cannot recognize test codes that contain these characters.

Field - Marks the beginning of a field. The vertical bar (|) character is the recommended field delimiter.

Repeat - Used to indicate that the previous field is to be repeated. Only certain fields, such as the Universal Test ID in the Test Order record, allow repeat delimiters. The number of repeat delimiters is restricted only by the 1024 character record size limit. The backslash (\) character is the recommended repeat delimiter.

Component - Used to delimit components of a multi-part field, such as Sender Name, which has a System ID component. The circumflex (^) character is the recommended component delimiter.

	<p>Escape - Used to include delimiters and other special characters in the field content without interpreting them in their usual function. The ampersand (&) is the recommended escape delimiter.</p> <p>To include a vertical bar as part of the content of a field, use & &. Likewise, to include an ampersand, use &&&.</p>
Sender Name or ID	<p>Used to identify the sender of the message. The instrument sends the word ACCESS followed by the System ID in a component field.</p> <p>System ID - Component field. Identifies the instrument. On the instrument, the value is configured from the System Setup screen. The contents must be alphanumeric.</p>
Receiver ID	<p>Identifies the intended target of the message. When downloading, the instrument will accept messages with any Receiver ID, including a null field. See the System ID component field description for the exception to this rule.</p> <p>System ID - Component field. When downloading, if the Receiver ID is ACCESS, the message is accepted only if this field matches the system ID of the instrument as configured from the System Setup screen, or is null. Otherwise the message is ignored. The contents are case sensitive.</p>
Processing ID	<p>Only the following code is used:</p> <p>P Production - Treat message as an active message to be completed according to standard processing.</p>
Version Number	<p>Version number of the LIS interface. Not updated from default.</p>
Date and Time of Message	<p>The date and time, in the format YYYYMMDDHHmmss. Although not required, including this field is good practice to support debug and message log analysis.</p>
End of Record	<p>Always the <CR> character.</p>

Patient Information Record

The Patient Information record contains patient identification information and demographic information, which is used by the instrument in range determination calculations.

All Test Order records that follow are associated with this patient until a subsequent patient record is encountered.

Examples

Typical Upload:

```
<STX>2P|1|098765678<CR><ETX>A3<CR><LF>
```

Typical Download:

```
<STX>2P|1|0987656789|||Smith^Tom^A^Jr.^Mr. ||19631124|M| ||||Jones<CR><ETX>6E<CR><LF>
```

Minimal Download:

```
<STX>2P|1|<CR><ETX>BB<CR><LF>
```

Table 3-3 Patient Information Record Fields

Description	Delimiter	Example	Max. Length	Instrument Receive	Instrument Send
Record Identifier	P		1	Required	Required
Sequence Number		1	5	Required	Required
Practice Assigned Patient ID		098765678	15	Required	Required if available
Laboratory Assigned Patient ID				Ignored	No
Patient ID #3				Ignored	No
Patient Name			40	Yes	No
Last Name		Smith			
First Name	^	Tom			
Middle Name	^	A			
Suffix	^	Jr.			
Title	^	Mr.			
Mother's Maiden Name				Ignored	No
Birth Date		19631124	8	Yes	No
Patient Sex		M	6	Yes	No

Table 3-3 Patient Information Record Fields (continued)

Description	Delimiter	Example	Max. Length	Instrument Receive	Instrument Send
Patient Race				Ignored	No
Patient Address				Ignored	No
Reserved Field				Ignored	No
Patient Telephone				Ignored	No
Attending Physician ID		Jones	40	Yes	No
Special Field #1				Ignored	No
Special Field #2				Ignored	No
Patient Height				Ignored	No
Patient Weight				Ignored	No
Patient Diagnosis				Ignored	No
Patient Medications				Ignored	No
Patient Diet				Ignored	No
Practice Field #1				Ignored	No
Practice Field #2				Ignored	No
Admission and Discharge Dates				Ignored	No
Admission Status				Ignored	No
Location				Ignored	No
Nature of Alt. Diagnostic Code & Classification				Ignored	No
Alternate Diagnostic Code & Classification				Ignored	No
Patient Religion				Ignored	No
Marital Status				Ignored	No
Isolation Status				Ignored	No
Hospital Service				Ignored	No
Hospital Institution				Ignored	No
Dosage Category				Ignored	No
End of Record	<CR>		1	Required	Required

Descriptions of Supported Patient Information Record Fields

Record Identifier	The Patient Information record is identified by the letter P in the Record Identifier field. Case sensitive.
Sequence Number	Begins with 1 and is incremented within the message for each subsequent patient record.
Practice Assigned Patient ID	<p>ID code assigned by the laboratory to uniquely identify the patient. This information is printed on the Patient Report, Sample Report, and Continuous Sample Report. It also is displayed on the Test Request screen and is sent in the Result upload message. If this field is null in a downloaded message, the patient information record will not update the sample demographic information on the instrument.</p> <p>The maximum length of this field is 15 characters (fewer if Simplified Chinese characters are used - see Appendix C: Japanese and Simplified Chinese Characters). If more than 15 characters are received, the instrument will accept the test request message, but will make the Patient ID field null and enter a message in the Event Log. Consequently, on upload, this field may be null. The contents must be alphanumeric, and are case sensitive.</p>
Patient Name	<p>The patient name is printed on the Patient Report and Sample Report. No entry or editing of this information is allowed on the instrument. This information will not be uploaded by the instrument. The combined maximum field length is 40 characters (fewer if Simplified Chinese characters are used - see Appendix C: Japanese and Simplified Chinese Characters). The contents are case sensitive.</p> <p>Last Name - The patient's last name.</p> <p>First Name - The patient's first name.</p> <p>Middle Name - The patient's middle name or initial.</p> <p>Suffix - Jr., Sr., or other applicable term.</p> <p>Title - Mr., Mrs., Dr., or other applicable term</p>
Birth Date	Numeric field only. Must be formatted YYYYMMDD. For example, the date November 24, 1963 must be transmitted to the instrument as 19631124. If invalid birth dates are received by the instrument, no birth is stored in the patient's demographic information. The instrument creates an event log entry and returns an error message to the laboratory computer. However, test orders are not rejected.

Patient Sex	<p>The following codes are supported by the instrument:</p> <ul style="list-style-type: none">M - MaleF - FemaleU - Unknown <p>The maximum field length is 6 characters. However, only the first character is used to assign a value to the field. Entries beginning with M are assigned Male. Entries beginning with F are assigned Female. Entries beginning with any other letter are assigned the value U for Unknown.</p> <p>Fields exceeding the 6-character maximum length will cause the message to be rejected.</p>
Attending Physician ID	<p>The field is case sensitive, and the maximum field length is 40 alphanumeric characters (fewer if Simplified Chinese characters are used - see Appendix C: Japanese and Simplified Chinese Characters).</p> <p>This field is accepted by the instrument on downloads, but is not sent by the instrument on uploads.</p>
End of Record	<p>Always the <CR> character.</p>

Test Order Record

The Test Order record contains information that uniquely identifies a sample, the list of tests to be completed, the priority, and the type of action requested.

All Test Order records are associated with the preceding Patient Information record. Result records that follow are associated with this Test Order record until a subsequent Test Order record is encountered.

Examples

Typical Download:

```
<STX>30|1|SPEC1234||^^^Ferritin|R|||||A|||Serum<CR><ETX>F8
<CR><LF>
```

Minimal Download:

```
<STX>30|1|SPEC1234||^^^Ferritin<CR><ETX>0E<CR><LF>
```

Typical Upload:

```
<STX>30|1|SPEC1234|^1^4|^ ^^Ferritin^2|||||||Serum|||||||F
<CR><ETX>34<CR><LF>
```

Table 3-4 Test Order Record Fields

Description	Delimiter	Example	Max. Length	Instrument Receive	Instrument Send
Record Identifier	O		1	Required	Required
Sequence Number		1	5	Required	Required
Specimen ID		SPEC1234	15	Required	Required
Instrument Specimen ID:					
Sample Tag				Ignored	No
Rack Number	^	1	4	Ignored	Yes
Sample Position	^	4	2	Ignored	Yes
Universal Test ID:					
Identifier				Ignored	No
Name	^			Ignored	No
Type	^			Ignored	No
Local Code: Test	^	Ferritin	8	Required	Yes
Local Code: Replicate	^	2	2	Ignored	Yes
Priority		R	9	Yes	No

Table 3-4 Test Order Record Fields (continued)

Description	Delimiter	Example	Max. Length	Instrument Receive	Instrument Send
Requested Date and Time				Ignored	No
Collection Date and Time				Ignored	No
Collection End Time				Ignored	No
Collection Volume				Ignored	No
Collector ID				Ignored	No
Action Code		A	1	Yes	No
Danger Code				Ignored	No
Relevant Clinical Information				Ignored	No
Date and Time Specimen Received				Ignored	No
Specimen Descriptor:					
Specimen Type		Serum	8	Yes	Yes
Specimen Source	^			Ignored	No
Ordering Physician				Ignored	No
Physician's Phone Number				Ignored	No
User Field #1				Ignored	No
User Field #2				Ignored	No
Laboratory Field #1				Ignored	No
Laboratory Field #2				Ignored	No
Date/Time Results Reported/Modified				Ignored	No
Instrument Charge to Computer System				Ignored	No
Instrument Section ID				Ignored	No
Report Types		F	1	Ignored	Yes
Reserved Field				Ignored	No

Table 3-4 Test Order Record Fields (continued)

Description	Delimiter	Example	Max. Length	Instrument Receive	Instrument Send
Local Specimen Collection				Ignored	No
Noscomial Infection Flag				Ignored	No
Specimen Service				Ignored	No
Specimen Institution				Ignored	No
End of Record	<CR>		1	Required	Required

Descriptions of Supported Test Order Record Fields

Record Identifier

The Test Order record is identified by the letter **O** in the Record Identifier field. Case sensitive.

Sequence Number

Begins with **1** and is incremented within the message for each subsequent Test Order record. A new Patient Information record resets the sequence number to **1**.

Specimen ID

Equivalent to the Sample ID on the instrument software. Identifies the specimen independently of the instrument rack ID and position. The maximum field length is 15 characters. The contents are case sensitive. Allowed characters are 0-9, A-Z, a-z, +, /, -, *. Spaces and punctuation are not allowed.

NOTE

A Specimen ID that matches a calibrator name (such as AFPCal) will be rejected.

Instrument Specimen ID

Only the second and third components of this field are supported. The first component is ignored by the instrument, and should be left blank by the laboratory computer.

Rack Number and Sample Position are uploaded to the laboratory computer but are ignored on downloads.

Rack Number - Numeric field containing the sample rack number read by the internal bar code reader in the instrument. Supported values are 1-9999.

Sample Position - Numeric field containing the position of the sample in the rack. Supported values are:

- 1-4 for the UniCel DxI instrument
- 1-10 for the Access 2 instrument

Universal Test ID	<p>Only the fourth and fifth components of this field are used. The first three components are ignored by the instrument, and should be left blank by the laboratory computer.</p> <p>The instrument supports repeat delimiters in this field. The instrument may produce repeat delimiters in this field when uploading Test Order records, to list each test code for each Result record to follow for a specific sample position.</p> <p>Local Code: Test - Alphanumeric field containing the test code for the instrument. The maximum field length is 8 characters. Test codes are not case sensitive. The hyphen character (-) may be used. For a list of available test codes, see Appendix B: Test Codes Used by the Instrument.</p> <p>Local Code: Replicate - On uploads, the instrument includes this component to indicate the test replicate number. Replicate numbers are ignored on downloads. The range of acceptable values is 1-99.</p>
Priority	<p>The following test priority codes are accepted:</p> <p>S - STAT</p> <p>R - Routine</p> <p>Although the instrument accepts up to nine characters, the priority code is the first character in the field.</p> <p>Code S gives a test order STAT priority.</p> <p>Code R or a null field gives the order routine priority.</p> <p>If any other code is used, the test order is rejected and an error message is returned to the LIS.</p>
Action Code	<p>The action to take for the test codes named in this record, indicated by one of the following codes:</p> <p>C - Cancel the tests for the indicated sample. The instrument removes the tests from the LIS workpool.</p> <p>A - Add the test to the indicated sample. If the sample location is unknown on the instrument, add the sample with the indicated test requests to the LIS workpool.</p> <p>N - New tests for the indicated sample. If tests are already associated with the sample, the new tests are rejected.</p> <p>If this field is null, it is received as an Add request.</p>

Specimen Descriptor	<p>Only the first component of the Specimen Descriptor is used.</p> <p>Specimen Type - The instrument supports the following specimen types:</p> <ul style="list-style-type: none">• Amniotic• Blood• Cervical• CSF• Plasma• Ratio• Saliva• Serum• Synovial• Urethral• Urine• Other <p>If no Specimen Type is received in a download, and no tests are assigned to the sample, the instrument uses the default sample type for the first test received for the sample. The default sample type is set up on the instrument Test Setup screen. Not case sensitive.</p>
Report Types	<p>The following codes are used by the instrument when uploading messages:</p> <p>F - Final results</p> <p>X - Results cannot be generated, request cancelled</p>
End of Record	<p>Always the <CR> character.</p>

Result Record The Result record contains information regarding a particular test that identifies the result value and units, the demographic range information, the condition of the result (normal or abnormal), and the date and time of the test.

All Result records are associated with the preceding Test Order record.

If a test result includes one or more flags, the flags are uploaded separately in a Comment record immediately following the Result record containing the flagged results.

The instrument can be configured to send results to the laboratory computer either when each test is finished (LIS Send Mode is By Test), or when all of the tests on a sample container are finished (LIS Send Mode is By Sample Container).

Examples

Typical Upload:

```
<STX>4R|1|^F^Ferritin^1|105.6|ng/ml||N||F|||20111231235959<CR>
<ETX>54<CR><LF>
```

Interpreted Result Upload:

```
<STX>3R|1|^F^Rub-IgG^1|0.24^Non-React.|S/CO||N||F|||20111231235959
9<CR><ETX>36<CR><LF>
```

Possible Upload:

```
<STX>3R|1|^F^TU^1|Cancelled|%Uptake||N||X|||20111231235959<CR>
<ETX>67<CR><LF>
```

Table 3-5 Result Record Fields

Description	Delimiter	Example	Max. Length	Instrument Receive	Instrument Send
Record Identifier	R		1	No	Required
Sequence Number		1	5	No	Required
Universal Test ID:					
Identifier				No	No
Name	^				No
Type	^				No
Local Code: Test	^	Ferritin	8		Required
Local Code: Replicate	^	1	8		Required

Table 3-5 Result Record Fields (continued)

Description	Delimiter	Example	Max. Length	Instrument Receive	Instrument Send
Data Measurement and Value:					
Value		105.6	9	No	Yes
Interpretation	^		10	No	Yes
Units		ng/mL	8	No	Yes
Reference Ranges		23.9 to 336.2	21	No	Yes
Reference Type	^	Normal	6	No	Yes
Result Abnormal Flags		N	2	No	Yes
Nature of Abnormality Testing		A	5	No	Yes
Result Status		F	1	No	Yes
Date of Change				No	No
Operator Identification				No	No
Date and Time Test Started				No	No
Date and Time Test Completed		20111231235959	14	No	Yes
Instrument Identification			40	No	Yes
End of Record	<CR>		1	No	Required

Descriptions of Supported Result Record Fields

Record Identifier

The Result record is identified by the letter **R** in the Record Identifier field. Case sensitive.

Sequence Number

Begins with **1** and is incremented within the message for each subsequent Result record. A new Test Order record will reset the Result record Sequence Number to **1**.

Universal Test ID	<p>Only the fourth and fifth components of this field are used. Repeat delimiters are not used for this field in the Result record.</p> <p>Local Code: Test - Alphanumeric field containing the test code for the instrument. The maximum field length is 8 characters. Not case sensitive. The hyphen character (-) may be used. For a list of available test codes, see Appendix B: Test Codes Used by the Instrument.</p> <p>Local Code: Replicate - Numeric value that specifies the replicate number for a particular assay. Supported values of 1-99.</p>
Data Measurement and Value	<p>The test result is reported in the two components of this field.</p> <p>Value - Alphanumeric test result. Other possible values are Cancelled, N/A, and No Value. This field is empty if result is fatally flagged.</p> <p>Interpretation - This field indicates the interpretation of the result value. The following codes are used: Reactive, Non-React., Confirmed, Not Conf., Negative, Positive, Equivocal.</p>
Units	<p>Alphanumeric representation of the units expressed in Data Measurement and Value. This field is empty if result is fatally flagged.</p>
Reference Ranges	<p>Alphanumeric representation of the demographic reference range used for the result.</p>
Reference Type	<p>Possible values are Normal and Panic.</p>

Result Abnormal Flags	<p>This field indicates the status of the result. The following codes are used:</p> <p>L Below normal reference low limit. Indicates an instrument ORL flag.</p> <p>H Above normal reference high limit. Indicates an instrument ORH flag.</p> <p>LL Below panic low. Indicates an instrument CRL flag.</p> <p>HH Above panic high. Indicates an instrument CRH flag.</p> <p>> Out of range high. Indicates an instrument OVR flag.</p> <p>N Normal result. Result not flagged ORH, ORL, CRH, CRL, or OVR.</p> <p>< Under for positive slope assays (or over for negative slope assays). The threshold limit is defined in the instrument assay protocol file (APF).</p> <p>This field is empty if result is fatally flagged.</p>
Nature of Abnormality Testing	<p>Possible values are:</p> <p>A Age</p> <p>S Sex</p> <p>N Generic Normal</p> <p>The instrument may use the Repeat delimiter to report multiple indications.</p>
Result Status	<p>Possible values are:</p> <p>F Final results.</p> <p>X Results cannot be generated. Request is not honored, or result is fatally flagged.</p>
Date and Time Test Completed	Date and time in the format YYYYMMDDHHmmss.
Instrument Identification	The system ID of the instrument reporting the test results, as configured from the System Setup screen.
End of Record	Always the <CR> character.

Comment Record

The Comment record is uploaded immediately following a Result record for a result that contains one or more flags.

When the instrument finds an error in a patient or test order record which will prevent tests from being ordered, it uploads a Patient Information record, Test Order record and Comment record containing an error message in an informational comment to the laboratory computer.

If multiple Result records are uploaded in a message, the Comment record applies to the Test Result record immediately preceding the Comment record.

Examples:

Typical Uploads:

```
<STX>4C|1|I|CEX;PEX|I<CR><ETX>42<CR><LF>
<STX>4C|1|I|Assay Not Enabled|G<CR><ETX>55<CR><LF>
```

Table 3-6 Comment Record Fields

Description	Delimiter	Example	Max. Length	Instrument Receive	Instrument Send
Record Identifier	C		1	No	Required
Sequence Number		1	5	No	Required
Comment Source		I	1	No	Yes
Comment Text		CEX; PEX	160	No	Yes
Comment Type		I	1	No	Yes
End of Record	<CR>		1	No	Required

Descriptions of Supported Comment Record Fields

Record Identifier	The Comment record is identified by the letter C in the Record Identifier field.
Sequence Number	Always 1 .
Comment Source	Indicates the source of the comment. Only the following code is used: I - Clinical instrument system

Comment Text There are two types of text comments: informational comments, and flags. Informational comments are sent in English for all languages except Japanese and Simplified Chinese. For Japanese LIS hosts, comments are sent using Half-Width Katakana characters. For Chinese LIS hosts, comments are sent in GB2312 Simplified Chinese characters. Flag comments are always sent in English, regardless of the language configured for the instrument user interface.

The instrument transmits flags in the Comment Text field of the Comment record following Test Result records.

NOTE

Multiple flags are delimited with semicolons.

The following codes are defined for flags:

CEX	Calibration curve or cut-off value expired.
CLX	Calibrator lot expired.
CRH	Result higher than critical (panic) reference range.
CRL	Result lower than critical (panic) reference range.
EXS	Substrate expired.
GRY	Qualitative result in gray zone.
LEX	Reagent or diluent pack lot expired.
LOW	Result lower than the minimum reportable result.
LRH	The result is above the upper limit of the LIS range.
LRL	The result is below the lower limit of the LIS range.
ORH	Result higher than normal reference range.
ORL	Result lower than normal reference range.
OVR	Result out of range of calibration.
PEX	Open pack stability time expired for reagent or diluent pack.
QCF	Control is outside QC limits (Westgard rule violation).
QEX	Quality control lot expired.
RFX	The result is from a reflex test.
TRA	Sample wheel temperature out of range.
TRR	Reagent storage chamber temperature out of range.

- Comment Type** Used to indicate type of comment. The following codes are used:
 - G** Generic/Free Text Comment (for error messages)
 - I** Instrument Flag Comment (for test result flags)
- End of Record** Always the <CR> character.

Request Information Record

The Request Information record is used to query the laboratory computer for test order information for a specific specimen ID.

Example

Upload message for a single specimen ID:

```
<STX>2Q|1|^Samp45||ALL|||||||O<CR><ETX>15<CR><LF>
```

Table 3-7 Request Information Record Fields

Description	Delimiter	Example	Max. Length	Instrument Receive	Instrument Send
Record Identifier	Q		1	No	Required
Sequence Number		1	5	No	Required
Starting Range ID Number:					
Patient ID Number				No	No
Specimen ID Number	^	Samp45	15	No	Yes
Ending Range ID Number				No	No
Universal Test ID		All		No	Yes
Nature of Request Time Limits				No	No
Beginning Request Results Date and Time				No	No
Ending Request Results Date and Time				No	No
Requesting Physician Name				No	No
Requesting Physician Telephone Number				No	No
User Field #1				No	No

Table 3-7 Request Information Record Fields (continued)

Description	Delimiter	Example	Max. Length	Instrument Receive	Instrument Send
User Field #2				No	No
Request Information Status Codes		O	1	No	Yes
End of Record	<CR>		1	No	Required

Descriptions of Supported Request Information Record Fields

Record Identifier	The Request Information record is identified by the letter Q in the Record Identifier field.
Sequence Number	Always 1 .
Starting Range ID Number	The second component of this field is a single specimen ID which corresponds to the 15-character sample ID in the instrument. Specimen ID Number - This component specifies a single specimen ID which corresponds to the 15-character sample ID in the instrument.
Universal Test ID	Always All , to query for all demographics and test orders for this specimen.
Request Information Status Codes	Always O , to query for demographics and test orders only.
End of Record	Always the <CR> character.

Message Terminator Record

The Message Terminator record signals the end of the message.

Example:

Typical upload or download:

```
<STX>4L|1|F<CR><ETX>FF<CR><LF>
```

Table 3-8 Message Terminator Record Fields

Description	Delimiter	Example	Max. Length	Instrument Receive	Instrument Send
Record Identifier	L		1	Required	Required
Sequence Number		1	5	Required	Required
Termination Code		F	1	Ignored	Yes
End of Record	<CR>		1	Required	Required

Descriptions of Supported Terminator Record Fields

- Record Identifier** The Message Terminator record is identified by the letter **L** in the Record Identifier field.
- Sequence Number** Always **1**.
- Termination Code** Provides an explanation for the end of the session. The following code is used for all uploaded messages:
F - Last request for information processed.
- End of Record** Always the **<CR>** character.

Manufacturer Information Record

The Manufacturer Information record is ignored when received by the instrument, and is not created or sent by the instrument.

Scientific Record

The Scientific record is ignored when received by the instrument, and is not created or sent by the instrument.

4 Sample Messages

The following examples show messages transmitted between the instrument and the laboratory computer.

Example 1: Request for Information (Host Query)

When a rack is loaded, the instrument checks to see if there are tests ordered for the samples in the rack. If no test orders are pending, and Host Query is enabled, the instrument sends a Request Information message to the laboratory computer. The instrument then waits for a response for the period of time defined in the instrument LIS setup. The instrument interprets the next message it receives during this time-out period as the response to its query.

Upload, Request Information (Query)

When performing a query for test requests from the instrument LIS Diagnostics screen, the following encoding is used. The <ENQ>, <STX>, and <EOT> come from the instrument; the <ACK> comes from the LIS.

```
<ENQ>
<ACK>
<STX>1H|\^&|||Sender||||Receiver||P|1|DateandTimeofMessageYYYYMMD
DHHMSS<CR><ETX>XX<CR><LF>
<ACK>
<STX>2Q|1|^SpecimenID||ALL||||||O<CR><ETX>XX<CR><LF>
<ACK>
<STX>3L|1|TerminationCode<CR><ETX>XX<CR><LF>
<ACK>
<EOT>
```

```
H|\^&|||ACCESS^500001||||LIS||P|1|20111010085833<CR>
Q|1|^Samp45||ALL||||||O<CR>
L|1|F<CR>
```

In this example, the instrument sends a query to the laboratory computer for test information for sample ID **Samp45**, after the rack containing this sample is loaded onto the instrument.

Download, Query Response, Test Available

In a reply from the LIS Host to the instrument, the following encoding is used. The <ENQ>, <STX>, and <EOT> come from the LIS; the <ACK> comes from the instrument.

```
<ENQ>
<ACK>
<STX>1H|\^&|||Sender|||Receiver||P|1|DateandTimeofMessageYYYYMMD
DHHMMSS<CR><ETX>XX<CR><LF>
<ACK>
<STX>2P|1|PracticeAssignedPatientID|||LastName^FirstName^MiddleNam
e^Suffix^Title||BirthDateYYYYMMDD|PatientSex||AttendingPhysicianID
<CR><ETX>XX<CR><LF>
<ACK>
<STX>3O|1|SpecimenID||^TestOrder\^TestOrder\^TestOrder|Prior
ity|||ActionCode|||SpecimenDescriptor<CR><ETX>XX<CR><LF>
<ACK>
<STX>4L|1|TerminationCode<CR><ETX>XX<CR><LF>
<ACK>
<EOT>
```

```
H|\^&|||LIS|||ACCESS^500001||P|1|20111010080000<CR>
P|1|435600||Amundson^Madelyn^Anne^Mrs^|19430421|F|Dr N Naidu 433<CR>
O|1|Samp45||^TSH\^FT4\^TU|R|||A|||Serum<CR>
L|1|F<CR>
```

In this example, the laboratory computer responds to a query for sample **Samp45** with test orders for TSH, FT4, and TU.

Download, Query Response, Test Unavailable

```
H|\^&|||LIS|||ACCESS^500001||P|1|20111010080000<CR>
L|1|F<CR>
```

In this example, the laboratory computer responds to a query for sample **Samp45** with a message indicating that no tests are available for the sample.

Example 2: Tests Ordered and Results Reported

In the following six sample messages, a series of tests are ordered and then results are reported. The first two messages are downloaded from the laboratory computer to the instrument, to order tests on four samples from three different patients. The next four messages are uploaded from the instrument to the laboratory computer, to report the results of the ordered tests.

Download with Test Orders for Multiple Patients

```
H|\^&|||Host LIS|||||P|1|20111010080000<CR>
P|1|AbelCindy<CR>
O|1|123456||^TSH|R||||A|||Serum<CR>
P|2|32445||Baker^Tom^M^S^Mr||19530101|M<CR>
O|1|123458||^TSH|R||||A|||Serum<CR>
O|2|123458||^TSH|R||||A|||Serum<CR>
L|1|F<CR>
```

In this example, the laboratory computer orders tests for two different patients.

The first patient is identified by the Patient ID of AbleCindy. One TSH test is ordered on Sample ID 123456.

The second patient's Patient ID is 32445, and his name, birth date, and sex are included. Two TSH tests are ordered on Sample ID 123458. The tests are ordered in separate records.

Download with Multiple Test Orders for One Patient

```
H|\^&|||Host LIS|||||P|1|20111010080000<CR>
P|1|CasperJane|||Johnson^Joan||19580101|F<CR>
O|1|AABB1234||^EPO\^Ferritin\^Ferritin|R||||A|||Serum<CR>
O|2|AABB1235||^TSH|R||||A|||Serum<CR>
L|1|F<CR>
```

In this example, a third patient is identified with a Patient ID of CasperJane. A total of four tests are ordered on two samples. For Sample ID AABB1234, one EPO test and two Ferritin tests are ordered. For Sample ID AABB1235, one TSH test is ordered.

Upload with Single Result

```
H|\^&||ACCESS^500001||||LIS||P|1|20111010131522<CR>
P|1|AbleCindy<CR>
O|1|123456|^9^1|^^TSH^1|||||||Serum|||||||F<CR>
R|1|^^TSH^1|0.18|uIU/mL||N||F|||20111010113536<CR>
L|1|F<CR>
```

In this example, the instrument reports the results of the downloaded test order for Patient ID AbleCindy. Sample ID 123456 was found in position 1 of sample rack 9. The test result is 0.18 μ IU/mL of TSH.

Upload for One Sample Container with Multiple Results

```
H|\^&||ACCESS^500001||||LIS||P|1|20111010131522<CR>
P|1|23445<CR>
O|1|123458|^9^2|^^TSH^1|||||||Serum|||||||F<CR>
R|1|^^TSH^1|0.03|uIU/mL||N||F|||20110131113612<CR>
O|2|123458|^9^2|^^TSH^1|||||||Serum|||||||F<CR>
R|2|^^TSH^2|0.01|uIU/mL||N||F|||20110131113648<CR>
L|1|F<CR>
```

In this example, the instrument reports the results of the downloaded test order for Patient ID 23445. Sample ID 123458 was found in position 2 of rack 9. There are two results. In the first test, 0.03 μ IU/mL of TSH was found. In the second test, 0.01 μ IU/mL of TSH was found.

NOTE

The instrument in this example has the LIS Send Mode set to **By Sample Container**. If the LIS Send Mode was set to **By Result**, each result would be reported in a separate message.

Upload for Result with Reagent Pack Expired Flag

```

H|\^&||ACCESS^500001||||LIS||P|1|20111010131522<CR>
P|1|CasperJane<CR>
O|1|AABB1234|^9^3|^^^EPO^1\^^^Ferritin^1\^^^Ferritin^2|||||||Serum|||||||F<C
R>
R|1|^^^EPO^1|0.13|mIU/mL||N|F||||20110131111100<CR>
C|1|I|PEX|I<CR>
R|2|^^^Ferritin^1|0.0|ng/mL||N|F||||20110131112300<CR>
R|3|^^^Ferritin^2|0.0|ng/mL||N|F||||20110131112336<CR>
L|1|F<CR>

```

In this example, the instrument reports the results of the downloaded test order for Sample ID AABB1234, from Patient ID CasperJane. The Comment record included after Result record number 1 indicates that the EPO reagent pack has expired (PEX flag).

Upload for Single Result

```

H|\^&||ACCESS^500001||||LIS||P|1|20111010131522<CR>
P|1|CasperJane<CR>
O|1|AABB1235|^9^4|^^^TSH^1|||||||Serum|||||||F<CR>
R|1|^^^TSH^1|0.02|uIU/mL||N|F||||20110131113636<CR>
L|1|F<CR>

```

In this example, the instrument reports the results of the downloaded test order for Sample ID AABB1235, from Patient ID CasperJane.

Example 3: Upload with Multiple Tests and Flags

```
H|\^&|||ACCESS^500001|||LIS||P|1|20111010115158<CR>
P|1|<CR>
O|1|47G|^1^3|^^^FOLW^1\^^^Ferritin^1\^^^VitB12^1\^^^Rub-IgG^1|||||Serum|||||
||F<CR>
R|1|^^^FOLW^1|0.09|ng/mL||N||F|||20111010115045<CR>
R|2|^^^Ferritin^1|0.0|ng/mL||N||F|||20111010114745<CR>
R|3|^^^VitB12^1|00|pg/mL||N||F|||20111010115121<CR>
L|1|F<CR>
```

The instrument reports results for Sample ID 47G. In this example, the LIS Send Mode on the instrument is set to **By Sample Container**, so all results for the sample are sent in one message. One replicate each of FolW, Ferritin, VitB12, and Rub-IgG was requested. The test was ordered at the instrument console, without a Patient ID. Because of a fatal flag, no result was calculated for the Rub-IgG test, so no result is sent to the laboratory computer. Only non-fatally flagged results are transmitted to the laboratory computer.

Example 4: Upload with Rejection Notification

```
H|\^&|||ACCESS^500001|||LIS||P|1|20111010085833<CR>
P|1|675DRC4<CR>
O|1|W3|^|^EPO|||||Serum|||||X<CR>
C|1|I|Sample already exists|G<CR>
L|1|F<CR>

H|\^&|||ACCESS^500001|||LIS||P|1|20111010085834<CR>
P|1|675DRC4<CR>
O|1|W3|^|^Ferritin|||||Serum|||||X<CR>
C|1|I|Sample already exists|G<CR>
L|1|F<CR>
```

In this example, the instrument sends rejection notification messages for Sample ID W3. This Sample ID already exists on the instrument and therefore cannot be accepted as a new test order (assuming that the action code in the downloaded Test Order record was N). The rejections are sent in separate messages because the instrument LIS Send Mode is set to **By Test**.

Example 5: Upload, FTIndex Reported

```
H|\^&|||ACCESS^500001|||LIS||P|1|20111010114936<CR>
P|1|DOEjane<CR>
O|1|661|^1^1|^^TotT4^1\^^TotT4^2\^^TU^1\^^TU^2|^^FTIndex^1|||Serum|||
|||F<CR>
R|1|^^TotT4^1|3.33|ug/dL||N||F|||20111010114333<CR>
R|2|^^TotT4^2|3.33|ug/dL||N||F|||20111010114333<CR>
R|3|^^TU^1|15.33|%Uptake||N||F|||20111010114221<CR>
R|4|^^TU^2|15.33|%Uptake||N||F|||20111010114857<CR>
R|5|^^FTIndex^1|1.28|ug/dL||N||F|||20111010114931<CR>
L|1|F<CR>
```

In this example, the instrument reports results for Sample ID 661. Two replicates of TotT4 and two replicates of TU were ordered. The FTIndex was not ordered (it cannot be ordered using the LIS interface), but it was generated automatically when valid TotT4 and TU results were obtained. The instrument LIS Send Mode is set to **By Sample Container**, so all results for the sample are sent in one message.

Appendix A: ASCII Character Codes

Table A-1 lists the 128 characters in the 7-bit ASCII character set, and shows the key-stroke, decimal value, hexadecimal value, character name, and description of each character. Control character (decimal value 0-31, and 127) keystrokes are preceded by a ^ character, to indicate that the <CTRL> key must be held down while pressing the associated key.

Table A-1 ASCII Character Codes

Key	Dec	Hex	Character	Description
^@	0	00	<NUL>	null
^a	1	01	<SOH>	start of heading
^b	2	02	<STX>	start of text
^c	3	03	<ETX>	end of text
^d	4	04	<EOT>	end of transmission
^e	5	05	<ENQ>	enquiry
^f	6	06	<ACK>	acknowledge
^g	7	07	<BEL>	bell
^h	8	08	<BS>	backspace
^i	9	09	<TAB>	horizontal tab
^j	10	0A	<LF>	line feed
^k	11	0B	<VT>	vertical tab
^l	12	0C	<FF>	form feed
^m	13	0D	<CR>	carriage return
^n	14	0E	<SO>	shift out
^o	15	0F	<SI>	shift in
^p	16	10	<DLE>	data link escape

Table A-1 ASCII Character Codes (continued)

Key	Dec	Hex	Character	Description
^q	17	11	<DC1>	device control 1 (XON)
^r	18	12	<DC2>	device control 2
^s	19	13	<DC3>	device control 3 (XOFF)
^t	20	14	<DC4>	device control 4
^u	21	15	<NAK>	negative acknowledge
^v	22	16	<SYN>	synchronous idle
^w	23	17	<ETB>	end of transmission block
^x	24	18	<CAN>	cancel
^y	25	19		end of medium
^z	26	1A	<SUB>	substitute
^[27	1B	<ESC>	escape
^\	28	1C	<FS>	file separator
^]	29	1D	<GS>	group separator
^^	30	1E	<RS>	record separator
^_	31	1F	<US>	unit separator
SP	32	20	<space>	space
!	33	21	!	exclamation point
"	34	22	"	double quote
#	35	23	#	number sign
\$	36	24	\$	dollar sign
%	37	25	%	percent sign
&	38	26	&	ampersand
'	39	27	'	apostrophe
(40	28	(left parenthesis

Table A-1 ASCII Character Codes (continued)

Key	Dec	Hex	Character	Description
)	41	29)	right parenthesis
*	42	2A	*	asterisk
+	43	2B	+	plus sign
,	44	2C	,	comma
-	45	2D	-	hyphen, minus sign
.	46	2E	.	period
/	47	2F	/	forward slash
0	48	30	0	digit 0
1	49	31	1	digit 1
2	50	32	2	digit 2
3	51	33	3	digit 3
4	52	34	4	digit 4
5	53	35	5	digit 5
6	54	36	6	digit 6
7	55	37	7	digit 7
8	56	38	8	digit 8
9	57	39	9	digit 9
:	58	3A	:	colon
;	59	3B	;	semicolon
<	60	3C	<	less than
=	61	3D	=	equal sign
>	62	3E	>	greater than
?	63	3F	?	question mark
@	64	40	@	at sign

Table A-1 ASCII Character Codes (continued)

Key	Dec	Hex	Character	Description
A	65	41	A	capital A
B	66	42	B	capital B
C	67	43	C	capital C
D	68	44	D	capital D
69	69	45	E	capital E
F	70	46	F	capital F
G	71	47	G	capital G
H	72	48	H	capital H
I	73	49	I	capital I
J	74	4A	J	capital J
K	75	4B	K	capital K
L	76	4C	L	capital L
M	77	4D	M	capital M
N	78	4E	N	capital N
O	79	4F	O	capital O
P	80	50	P	capital P
Q	81	51	Q	capital Q
R	82	52	R	capital R
S	83	53	S	capital S
T	84	54	T	capital T
U	85	55	U	capital U
V	86	56	V	capital V
W	87	57	W	capital W
X	88	58	X	capital X

Table A-1 ASCII Character Codes (continued)

Key	Dec	Hex	Character	Description
Y	89	59	Z	capital Y
Z	90	5A	Z	capital Z
[91	5B	[left bracket
\	92	5C	\	backslash
]	93	5D]	right bracket
^	94	5E	^	circumflex
_	95	5F	_	underscore
‘	96	60	‘	grave accent
a	97	61	a	small a
b	98	62	b	small b
c	99	63	c	small c
d	100	64	d	small d
e	101	65	e	small e
f	102	66	f	small f
g	103	67	g	small g
h	104	68	h	small h
i	105	69	i	small i
j	106	6A	j	small j
k	107	6B	k	small k
l	108	6C	l	small l
m	109	6D	m	small m
n	110	6E	n	small n
o	111	6F	o	small o
p	112	70	p	small p

Table A-1 ASCII Character Codes (continued)

Key	Dec	Hex	Character	Description
q	113	71	q	small q
r	114	72	r	small r
s	115	73	s	small s
t	116	74	t	small t
u	117	75	u	small u
v	118	76	v	small v
w	119	77	w	small w
x	120	78	x	small x
y	121	79	y	small y
z	122	7A	z	small z
{	123	7B	{	left brace
 	124	7C		vertical bar
}	125	7D	}	right brace
~	126	7E	~	tilde
^?	127	7F		delete

Appendix B: Test Codes Used by the Instrument

The following list contains typical test codes used by the instrument. Test codes are not case sensitive.

This Access Test Codes list is subject to change without notification. Tests listed may or may not be available for use with commercial systems. The availability of any assay in your country depends on the status of submissions to local regulatory agencies. **Contact your Beckman Coulter representative for more information on test availability.**

NOTE

The instrument Tests screen displays the test codes available on the instrument.

Table B-1 Access Test Codes

Access Code	Remisol Code	DxC Integrated Code	Access Assay Name
AcB12	A204	AcB12	Active-B12
AcBd	A205	AcBd	Active-B12-Diluted (Onboard Dilution - UniCel DxI systems only)
AFP	A02	AFP	AFP (cancer and ONTD utility)
Dil-AFP	A77	dAFP	Diluted AFP (cancer and ONTD utility)
d-AFP	A143	d-AFP	AFP-Diluted (Onboard Dilution - UniCel DxI systems only)
AMH	A183	AMH	AMH
dAMH	A184	dAMH	AMH-Diluted (Onboard Dilution - UniCel DxI systems only)
AMH2	A215	AMH2	AMH Advanced
dAMH2	A216	dAMH2	AMH Advanced-Diluted (Onboard Dilution - UniCel DxI systems only)
B12II	A240	B12II	Vitamin B ₁₂ II
dB12II	A243	dB12II	Vitamin B12 II - Diluted (Onboard Dilution - UniCel DxI systems only)
BNP2	A148	BNP2	BNP

Table B-1 Access Test Codes (continued)

Access Code	Remisol Code	DxC Integrated Code	Access Assay Name
dBNP2	A149	dBNP2	BNP -Diluted (Onboard Dilution - UniCel DxI systems only)
BR15-3Ag	A04	BR153	BR Monitor
dBRAg	A35	dBRAg	BR Monitor-Diluted (Onboard Dilution - UniCel DxI systems only)
BV-Score	A254	n/a	MeMed BV [®] (Access 2 only)
CEA2	A104	CEA2	CEA
CK-MB	A49	CK-MB	CK-MB
dCKMB	A117	dCKMB	CK-MB-Diluted (Onboard Dilution - UniCel DxI systems only)
CMV-G	A110	CMV-G	CMV-IgG
CMV-M	A112	CMV-M	CMV-IgM
Cortisol	A10	Cort	Cortisol
CPep	A208	CPep	C-Peptide
uCPep	A209	uCPep	C-Peptide Onboard Pre-Dilution (UniCel DxI systems only)
DHE-S	A94	DHE-S	DHEA-S
dDHES	A144	dDHES	DHEA-S (Onboard Dilution - UniCel DxI systems only)
Dig	A11	Dig-	Digoxin
dDig	A150	dDig	Digoxin-Diluted (Onboard Dilution - UniCel DxI systems only)
E2	A101	E2	Estradiol
EPO	A81	EPO	EPO
dEPO	A160	dEPO	EPO-Diluted (Onboard Dilution - UniCel DxI systems only)
Ferritin	A19	Ferr	Ferritin
Dil-Fer	A83	dFer	Diluted Ferritin
d-Fer	A146	d-Fer	Ferritin-Diluted (Onboard Dilution - UniCel DxI systems only)

Table B-1 Access Test Codes (continued)

Access Code	Remisol Code	DxC Integrated Code	Access Assay Name
FOLW	A170	FOLW	Folate
dFOLW	A172	dFOLW	Folate-Diluted (Onboard Dilution - UniCel DxI systems only)
fPSA-WHO	A89	fPSAW	Hybritech free PSA (WHO calibration option)
freePSA	A63	fPSA	Hybritech free PSA (Hybritech calibration option)
FRT4	A91	FRT4	Free T4
FT3	A80	FT3	Free T3
FT4II	A228	FT4II	Free T4
FTIndex	A24		Free Thyroxine Index (the derived result is calculated using TotT4 and TU results; do not request this test)
GFAPRUO	n/a	n/a	GFAP (RUO) (For use on Access 2 systems only)
GI19-9Ag	A05	GI199	GI Monitor
dGIAG	A121	dGIAG	GI Monitor-Diluted (Onboard Dilution - UniCel DxI systems only)
GToxo	A103	GToxo	Toxo IgG
HAVAb	A26	HAVAb	HAV Ab
HAV-IgM	A25	HAV-M	HAV IgM
HBAb3	A107	HBAb3	HBs Ab
HBc-Ab	A27	HBcAb	HBc Ab
HBc-IgM	A28	HBc-M	HBc IgM
HBsAgV3	A98	HBsAg	HBs Ag (P/N A24291)
HBsBkV3	A99	HBsBk	HBs Ag Blocking (P/N A24295)
HBsCtV3	A100	HBsCt	HBs Ag Confirmatory (P/N A24295)
HCG5	A178	HCG5	Total β hCG (5 th IS) (P/N A85264)

Table B-1 Access Test Codes (continued)

Access Code	Remisol Code	DxC Integrated Code	Access Assay Name
HCG5d	A179	HCG5d	Diluted Total β hCG (5 th IS)
d-CG5	A180	d-CG5	Total β hCG-Diluted (5 th IS) (Onboard Dilution - UniCel DxI systems only)
HCV-V3	A185	HCV-3	HCV Ab V3
hFSH	A36	hFSH	hFSH
dhFSH	A122	dhFSH	hFSH-Diluted (Onboard Dilution - UniCel DxI systems only)
hGH2	A92	hGH2	Ultrasensitive hGH
dhGH2	A123	dhGH2	Ultrasensitive hGH-Diluted (Onboard Dilution - UniCel DxI systems only)
HIVc2	A219	HIVc2	HIV combo V2
HIVco	A167	HIVco	HIV combo
hLH	A39	hLH	hLH
dhLH	A124	dhLH	hLH-Diluted (Onboard Dilution - UniCel DxI systems only)
hsTnI	A195	hsTnI	hsTnI For use outside the U.S.A.
dhsTn	A196	dhsTn	hsTnI-Diluted (Onboard Dilution - UniCel DxI systems only) For use outside the U.S.A.
TnIhs	A142	TnIhs	hsTnI For use in the U.S.A.
dTIhs	A157	dTIhs	hsTnI-Diluted (Onboard Dilution - UniCel DxI systems only) For use in the U.S.A.
IFAb	A72	IFAb	Intrinsic Factor Ab
IgM-Toxo	A13	Tox-M	Toxo IgM II
IL-6	A87	IL-6	IL-6
dIL-6	A125	dIL-6	IL-6-Diluted (Onboard Dilution - UniCel DxI systems only)

Table B-1 Access Test Codes (continued)

Access Code	Remisol Code	DxC Integrated Code	Access Assay Name
IL-6RUO	A88	IL6RU	IL-6 RUO - For Research Use Only
dILRU	A140	dILRU	IL-6 RUO-Diluted For Research Use Only (Onboard Dilution - UniCel DxI systems only)
InhibinA	A96	InhbA	Inhibin A
dInhA	A126	dInhA	Inhibin A-Diluted (Onboard Dilution - UniCel DxI systems only)
Insulin	A40	Insul	Ultrasensitive Insulin
dIns	A127	dIns	Ultrasensitive Insulin-Diluted (Onboard Dilution - UniCel DxI systems only)
MRub	A102	MRub	Rubella IgM
MYO	A30	MYO	Myoglobin
dMYO	A128	dMYO	Myoglobin-Diluted (Onboard Dilution - UniCel DxI systems only)
NfLRUO	n/a	n/a	NfL (RUO) (For use on Access 2 systems only)
NTBNP	A257	n/a	NT-proBNP
Ostase	A12	Ostas	Ostase
dOst	A129	dOst	Ostase-Diluted (Onboard Dilution - UniCel DxI systems only)
OV125Ag	A03	OV125	OV Monitor (CA 125 Antigen)
dOVAg	A130	dOVAg	OV Monitor-Diluted (Onboard Dilution - UniCel DxI systems only)
p2PSA	A111	p2PSA	Hybritech p2PSA (for the calculation of prostate health index [phi])
P4DE	A116	P4DE	Progesterone
PanRUO	n/a	n/a	APOE ε4 (RUO) (For use on Access 2 systems only)
PAPPA	A108	PAPPA	PAPP-A (UniCel DxI systems only)

Table B-1 Access Test Codes (continued)

Access Code	Remisol Code	DxC Integrated Code	Access Assay Name
dPAPA	A152	dPAPA	PAPP-A-Diluted (Onboard Dilution - UniCel DxI systems only)
PAPPARUO	A113	PAPRU	PAPP-A RUO - For Research Use Only (UniCel DxI systems only)
dPARU	A153	dPARU	PAPP-A RUO-Diluted (Onboard Dilution - UniCel DxI systems only) - For Research Use Only
PCT	A206	PCT	PCT (P/N C22593) For use outside the U.S.A.
PCTd	A207	PCTd	PCT-Diluted (P/N C22593) (Onboard Dilution - UniCel DxI systems only) For use outside the U.S.A.
PrCT	A211	PrCT	PCT (P/N C53987) For use in the U.S.A.
PrCTd	A212	PrCTd	PCT-Diluted (P/N C53987) (Onboard Dilution - UniCel DxI systems only) For use in the U.S.A.
phi-HYB	A164		Prostate Health Index (Hybritech calibration option) (the derived result is calculated using PSA-Hyb, freePSA and P2PSA results; do not request this test)
phi-WHO	A163		Prostate Health Index (WHO calibration option) (the derived result is calculated using PSA-WHO, fPSA-WHO and P2PSA results; do not request this test)
PRL	A42	PRL	Prolactin
dPRL	A131	dPRL	Prolactin-Diluted (Onboard Dilution - UniCel DxI systems only)
Prog	A43	Prog	Progesterone
PROG2	A231	PROG2	Progesterone II

Table B-1 Access Test Codes (continued)

Access Code	Remisol Code	DxC Integrated Code	Access Assay Name
PSA-Hyb	A62	PSA	Hybritech PSA (Hybritech calibration option)
dPSA	A132	dPSA	Hybritech PSA-Diluted (Hybritech calibration option) (Onboard Dilution - UniCel DxI systems only)
PSA-WHO	A90	PSA-W	Hybritech PSA (WHO calibration option)
dPSAW	A133	dPSAW	Hybritech PSA-Diluted (WHO calibration option) (Onboard Dilution - UniCel DxI systems only)
PTH	A85	PTH	Intact PTH, Routine Mode
dPTH	A134	dPTH	Intact PTH-Diluted, Routine Mode (Onboard Dilution - UniCel DxI systems only)
PTHIO	A86	PTHIO	Intact PTH, Intraoperative Mode
dPTHi	A135	dPTHi	Intact PTH-Diluted, Intraoperative Mode (Onboard Dilution - UniCel DxI systems only)
RBCW	A171	RBCW	RBC Folate
Rub-IgG	A46	Rub-G	Rubella IgG
SHBG	A106	SHBG	SHBG
dSHBG	A154	dSHBG	SHBG-Diluted (Onboard Dilution - UniCel DxI systems only)
SNSE2	A200	SNSE2	Sensitive Estradiol
dSNE2	A201	dSNE2	Sensitive Estradiol-Diluted
sTfR	A95	sTfR	sTfR
dsTfR	A155	dsTfR	sTfR-Diluted (Onboard Dilution - UniCel DxI systems only)
sTfRIndx	A109	n/a	sTfR Index (the derived result is calculated using sTfR and Ferritin results; do not request this test)
TBhCG2	A17	TBhCG	Total β hCG (P/N 33500)

Table B-1 Access Test Codes (continued)

Access Code	Remisol Code	DxC Integrated Code	Access Assay Name
Dil-hCG2	A18	DlhCG	Diluted Total β hCG (P/N 33500)
d-ThCG	A145	d-hCG	Total β hCG-Diluted (P/N 33500) (Onboard Dilution - UniCel DxI systems only)
Testo	A16	Testo	Testosterone
Tg2	A190	Tg2	Thyroglobulin Version 2(P/N 33860)
Tg-Ab	A174	Tg-Ab	Thyroglobulin Antibody II (P/N A32898)
TgAby	A227	TgAby	Thyroglobulin Antibody II Biotin-Remediated (P/N C86552)
Thyg	A226	Thyg	Thyroglobulin Biotin-Remediated (P/N C71762)
TnIA2	A175	TnIA2	AccuTnI+3 (P/N A98143) (For use on Access 2 systems)
TnIDx	A176	TnIDx	AccuTnI+3 (P/N A98264) (For use on UniCel DxI systems)
TotT3	A50	TotT3	Total T3
TotT4	A52	TotT4	Total T4
TPAb	A250	n/a	Syphilis (For use on Access 2 systems only)
TPOAb	A79	TPOAb	TPO Antibody
dTPO	A136	dTPO	TPO Antibody-Diluted (Onboard Dilution - UniCel DxI systems only)
TropI	A115	TropI	AccuTnI (P/N A78803)
TSH3	A188	TSH3	TSH (3 rd IS)
TSH3d	A189	TSH3d	Diluted TSH (3 rd IS)
TT4II	A253	TT4II	Total T4 II
TU	A59	TU-	Thyroid Uptake
uE3	A15	uE3	Unconjugated Estriol (P/N 33570)
unE3	A210	unE3	Unconjugated Estriol (P/N C22255)

Table B-1 Access Test Codes (continued)

Access Code	Remisol Code	DxC Integrated Code	Access Assay Name
VitB12	A60	B12	Vitamin B ₁₂
dB12	A161	dB12	Vitamin B ₁₂ -Diluted (Onboard Dilution - UniCel DxI systems only)
VitdA	A182	VitdA	25(OH) Vitamin D Total (P/N B24838) (For use on Access 2 systems)
VitdD	A181	VitdD	25(OH) Vitamin D Total (P/N A98856) (For use on UniCel DxI systems)

Appendix C: Japanese and Simplified Chinese Characters

For instruments that are configured to support the Japanese or Chinese language, certain record fields can be sent and received using either U.S. ASCII, half-width Katakana, or Simplified Chinese characters.

The following record fields support extended ASCII Katakana and Simplified Chinese characters.

Patient Information Record

- Attending Physician ID
- Practice Assigned Patient ID
- Patient Name (Last^First^Middle^Suffix^Title)

Comment Record

- Comment Text, when the Comment Type is **G**. (Flags, in which the Comment Type is **F**, are always sent in English.)

NOTES

- Simplified Chinese characters each require two bytes. Therefore, if a field has a limitation of 40 characters, up to 20 Simplified Chinese characters may be entered in that field. Likewise, if a field has a limitation of 15 characters, up to 7 Simplified Chinese characters may be entered.
 - It is permissible to combine Simplified Chinese and U.S. ASCII characters in a field, provided that the total number of bytes does not exceed the limitation specified for that field.
 - Simplified Chinese is available on Access 2 systems, and on UniCel DxI systems with software versions 4.6 or higher.
-

Appendix D: EIA-232 Cables, Connectors, and Adapters

A number of cable and connector types are commonly used for EIA-232 serial communication connections. This appendix provides requirements and recommendations for successfully connecting a UniCel DxI or Access 2 Immunoassay System to a laboratory information system or data manager.

Instrument LIS Port

The instrument LIS port is the COM2 DB-9 male connector located on the back of the external PC. For the location of the port on a UniCel DxI system, see the External Computer Ports topic in the system *Help* or in the *Reference Manual*. For the location of the port on an Access 2 system, contact Technical Support.

The DB-9 male connector provides Receive Data (RD) on pin 2, Transmit Data (TD) on pin 3, and signal ground (GND) on pin 5. No other signals are required or supported.

NOTE

Beckman Coulter recommends that only the three supported signal lines be connected to the instrument LIS port. Connecting other signals may cause communication failure.

 <p style="text-align: right; font-size: small;">2308A.eps</p>		 <p style="text-align: right; font-size: small;">2307A.eps</p>	
Instrument LIS Port Configuration Provided on DB-9 Male Connector	Pin	Pin	Signals Required on Laboratory Computer Cable DB-9 Female Connector
RD	2	2	TD
TD	3	3	RD
GND	5	5	GND

Figure D-1 DB-9 Connector Pin Assignments

Wiring RJ-45 Adapters for Use with Category 5 Cable Runs

In installations where long cable runs are required, it is a common practice to run category 5 network cable terminated with RJ-45 modular connectors. When RJ-45 terminated cables are used, adapters are required at each end of the cable to connect to the DB-9 male connector on the instrument external computer, and to a DB-9 or DB-25 connector on the laboratory computer. Figure D-2 shows a typical category 5 cable run, in which the laboratory computer EIA-232 port is a DB-25 connector. Other configurations are possible.

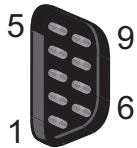
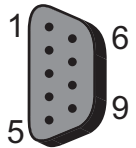
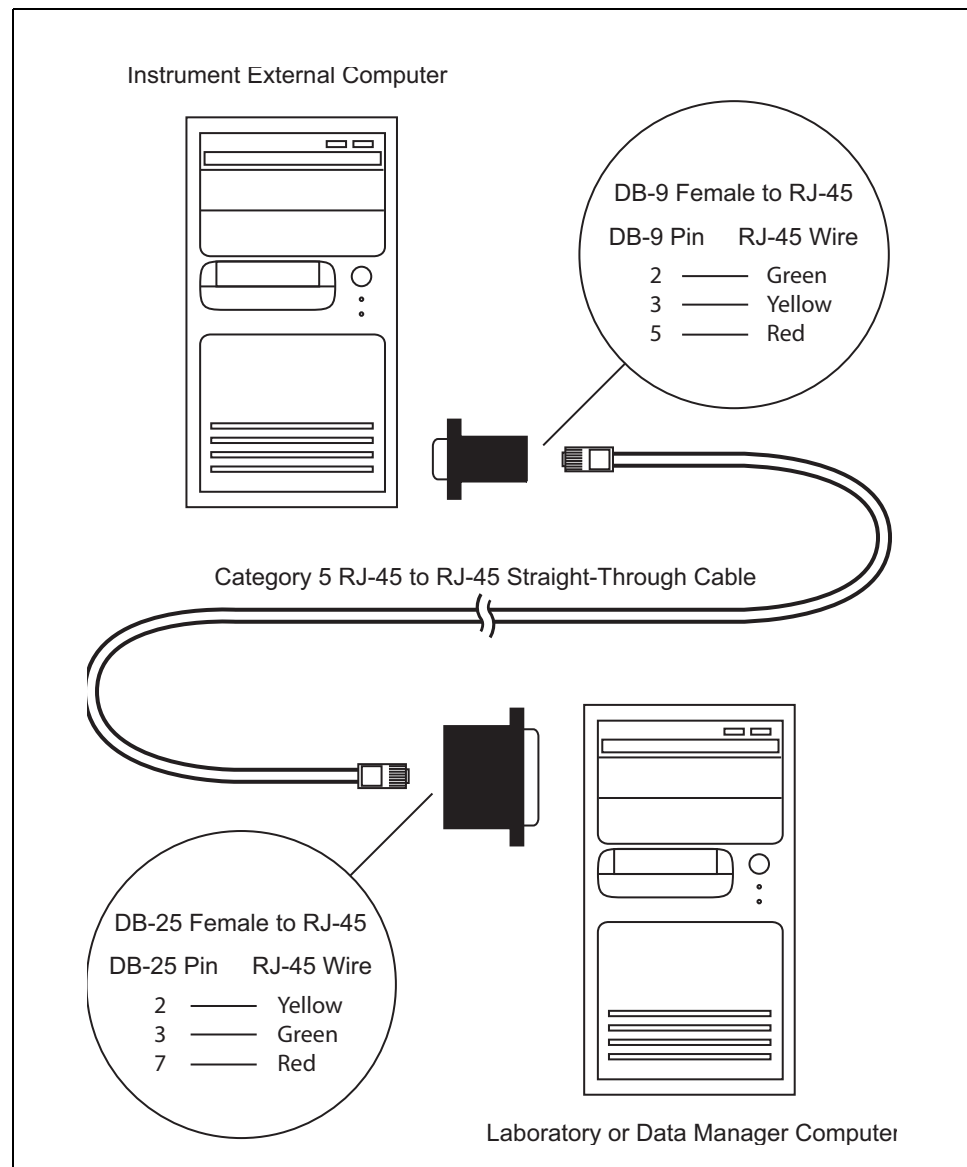

2306A.eps

Figure D-2 Typical Category 5 Cable Run with RJ-45 Adapters

NOTE

When wiring RJ-45 adapters, it is advisable to obtain an inexpensive pin extractor tool. Once pins are inserted in the DB connector, they cannot be removed without this tool. Pin extractors can be purchased at most electronics stores.

Beckman Coulter recommends that you

- Use only straight-through cables, where pin 4 at one end of the cable is connected to pin 4 at the other end, pin 5 is connected to pin 5, and pin 6 is connected to pin 6. See the Figure D-3 for a straight-through wiring diagram.
- Wire the RJ-45 adapter closest to the instrument external computer for null modem operation, and connect only the TD, RD, and GND wires.
- Wire the RJ-45 adapter closest to the laboratory computer straight-through.

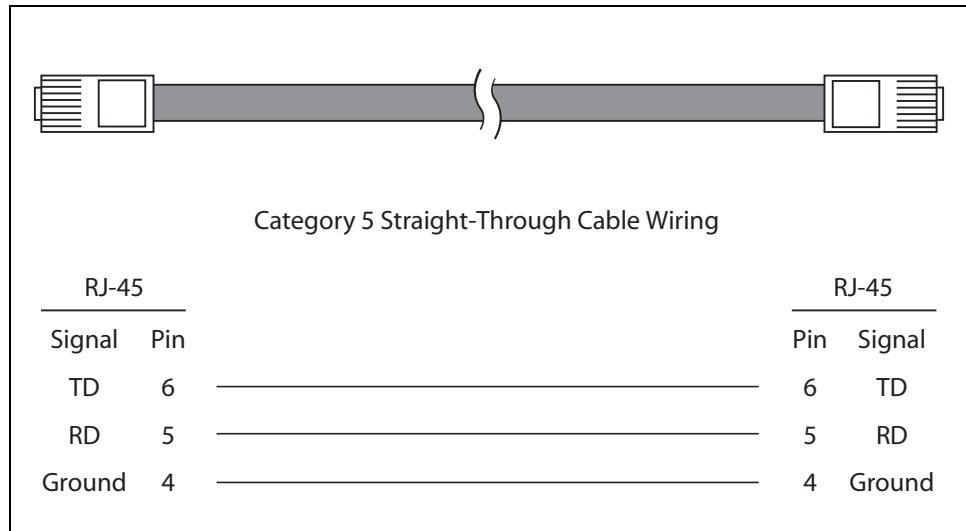

2309A.eps

Figure D-3 RJ-45 to RJ-45 Category 5 Straight-Through Cable