



Reference Manual

BECKMAN COULTER DxC 700 AU

For *In Vitro* Diagnostic Use



B71496AE
April 2021



Beckman Coulter, Inc.
250 S. Kraemer Blvd.
Brea, CA 92821 U.S.A.



Reference Manual

BECKMAN COULTER DxC 700 AU

PN B71496AE (April 2021)

© 2021 Beckman Coulter, Inc.
All Rights Reserved.

Trademarks

Beckman Coulter, the stylized logo, and the Beckman Coulter product and service marks mentioned herein are trademarks or registered trademarks of Beckman Coulter, Inc. in the United States and other countries.

All other trademarks are the property of their respective owners.

Find us on the World Wide Web at:

www.beckmancoulter.com



Beckman Coulter Ireland Inc.
Lismeehan, O'Callaghan's Mills,
Co. Clare, Ireland
Phone: +353-65-683-1100
FAX: +353-65-683-1122

Rx Only
Original Instructions

Revision History

This document applies to the latest software listed and higher versions. When a subsequent software version changes the information in this document, a new issue will be released.

B71496AE, 04/2021

Software version 1.0

This document was created to:

- Update the Test Volume and Methods: General Tab section.

B71496AD, 04/2019

Software version 1.0

This document was created to:

- Update Key Sub-Processes section.
- Update Common Test Parameters Menu section.
- Update Misc. Menu section.
- Update Lipemia, Icterus, and Hemolysis (LIH) section.
- Update Cautions with Cups or Tubes Specifications section.
- Update Display Reaction Monitor section.

B71496AC, 06/2018

Software version 1.0

- This document was created to document the changes in the software that enable the whole blood HbA1c testing function.
- Updated the minimum test volume only for Japan in System Monitoring and Results > Display Reaction Monitor. Changed it to a footnote:
- Replaced the following terms:
 - *[Test Order STAT]* with *[STAT Test Order]*
 - *alarm* with *event*
 - *STAT Start* with *Start STAT*
 - *Addition of User* with *Add User*
 - *Register user list* with *List of Registered Users*
 - *Send to LIS Stop* with *Stop Sending to LIS*
 - *Result Transfer* with *Analysis Results Transfer Mode*
 - *Data Not Transferred to LIS, Data Not Printed* with *Data Not Yet Transferred with LIS, Data Not Yet Printed*
 - *QC materials* with *control materials*

Revision History

- Updated the Bar Code Operation, Input Notes in Table 2.19 Calibrators Tab Description.

B71496AB, 03/2017

Software version 1.0

This document was created to add the CE mark to the title page.

Initial Issue, B71496AA, 12/2016

Software version 1.0

Warranty

The system is covered by and subject to the provisions of the warranty included in your contractual agreement for the system or its reagents.

The customer is responsible for routine preventive maintenance procedures. Repairs arising from the failure to perform these maintenance procedures at the indicated time intervals are made at the discretion of Beckman Coulter, and at the customer's expense.

Warranty

Contents

	Revision History, iii
	Warranty, v
	Safety Notice, xi
CHAPTER 1:	System Overview, 1-1
	Software Overview, 1-1
	Software Paths, 1-1
	Organization and Functional Outline of Test Results Menu, 1-1
	Organization and Functional Outline of Sample Program Menu, 1-3
	Organization and Functional Outline of STAT Menu, 1-3
	Organization and Functional Outline of Reagent Menu, 1-4
	Organization and Functional Outline of Maintenance Menu, 1-5
	Organization and Functional Outline of Quality Control Menu, 1-6
	Organization and Functional Outline of Calibration Menu, 1-7
	Organization and Functional Outline of Configuration Parameters Menu, 1-7
	Principles of Analysis, 1-11
	Reagent Blank, 1-12
	End Point Assays, 1-13
	Rate Assays, 1-15
	Quality Control, 1-16
	Summary of Calibration Types, 1-20
	Principles of the Real-time Water Blank Check, 1-23
	Principles of the ISE Measuring Method, 1-24
	Calibration Processing on the ISE, 1-24
	Calibration, 1-24
	Correction by M-CAL, 1-25
	Correction by A-CAL, 1-25
	Key Sub-Processes, 1-26
	Sample Identification, 1-26
	Sample Transfer, 1-27
	Reagent Transfer, 1-27
	Reaction Mixture Mixing, 1-28
	Reaction Mixture Incubation and Washing, 1-28
	Photometric Measurement, 1-28
	Online Test Orders and Test Orders Using Keyboard Entries, 1-28
	Sample Identification and Date and Time, 1-29
	Understanding and Handling Reagents, Calibrators, and Controls, 1-30
	Reagents, 1-30
	Sample Diluents, 1-30
	Calibrators, 1-30
	Quality Control Samples, 1-31

Contents

	ISE Quality Control Materials, 1-31
CHAPTER 2:	Parameters, 2-1
	Common Test Parameters Menu, 2-1
	Test Name Parameters Screen, 2-1
	Panel Screen, 2-6
	Group of Tests Screen, 2-10
	Specific Test Parameters Menu, 2-12
	Test Volume and Methods Screen, 2-12
	Rerun Test Parameters Screen, 2-30
	Rerun Check Parameters Screen, 2-33
	Calibration Setup Menu, 2-36
	Calibrators Tab, 2-36
	Calibration Setup: General Tab, 2-38
	Calibration Setup: ISE Tab, 2-41
	QC Setup Menu, 2-43
	Controls Tab, 2-43
	Check Tab, 2-45
	Preset Tab, 2-46
	Cumulative Tab, 2-48
	STAT Table Setup, 2-50
	STAT Table Setting Dialog, 2-50
	Auto ACAL/QC Setup Screen, 2-52
	Misc. Menu, 2-56
	Checked Tests Screen, 2-56
	Contamination Parameters Screen, 2-57
	Data Check Parameters Screen, 2-64
	System Condition Menu, 2-66
	Analysis Mode Screen, 2-66
	System Setup Screen, 2-72
	Program the Logon, 2-75
	Comment Master Screen, 2-81
	Online Menu, 2-82
	Program Online Parameters with RS232C Connection, 2-82
	Program Online Parameters with TCP/IP Connection, 2-89
	Sample Program Format Screen, 2-94
	List Format Screen, 2-97
	List Types Available in Specific Menus, 2-98
	Format Parameters for Each List Type, 2-99
	Layout Setting Parameters, 2-103
	Copy Format Parameters, 2-104
	Program List Formats, 2-105
	Save Data to a File, 2-107

	Add or Change a Comment, 2-108
	Program Realtime Print Options, 2-108
	Lipemia, Icterus, and Hemolysis (LIH), 2-110
	LIH Reagent, 2-111
	Program LIH, 2-111
	Running the LIH Test, 2-115
CHAPTER 3:	Sample Programming and Processing, 3-1
	Cautions with Cups or Tubes Specifications, 3-1
	Apply Bar Code Labels to Sample Tubes, 3-7
	NE Racks, 3-8
	Bar Code Labels for STAT Table Analysis, 3-8
	Apply a Rack ID Bar Code Label on the Rack, 3-9
	Use Adapters on Sample Racks, 3-10
	Insert an Adapter into a Rack, 3-10
	Remove an Adapter from a Rack, 3-11
CHAPTER 4:	System Monitoring and Results, 4-1
	Reagent Management, 4-1
	Review and Delete Reagent History, 4-1
	Recovering from a Bottle Position Error, 4-2
	Initialize Onboard Stability, 4-3
	Reagent Inventory, 4-3
	Reagent Consumption, 4-5
	Display Reaction Monitor, 4-7
	Monitor the Reagent Blank and Calibration, 4-12
	Reagent Blank and Calibration Status, 4-12
	Review Reagent Blank and Calibration History, 4-15
	Review Reagent Blank and Calibration Detailed Data, 4-16
	Monitor QC, 4-20
	Monitor the QC Using the Daily Variation Chart, 4-20
	Monitor the QC Using the Day-to-Day Variation Chart, 4-23
	Monitor the QC Using the Twin Plot Chart, 4-26
	Add a QC Comment, 4-28
	Edit Quality Control Data, 4-29
	Sample Management, 4-30
	Edit Patient Sample Data, 4-31
	Correct Patient Sample Data, 4-33
	Recalculate Analysis Data Using a Previous Calibration Curve, 4-36
	Send Data to Laboratory Information System, 4-37
	Calculate Data Statistics, 4-38
	View Data Statistics, 4-38
	Create a Correlation Chart, 4-42

Contents

	Save or Load Parameters, 4-45
APPENDIX A:	Specifications, A-1
	Sample Bar Code Label Specifications, A-1
	Bar Code Types, A-1
	Bar Code Digit Numbers, A-1
	Bar Code Label Size, A-2
	Bar and Space Widths, A-2
	Bar Code Check Methods, A-3
	Requirements for Printing Bar Code Labels, A-3
APPENDIX B:	Additional Software Screens, B-1
	Sample Status Screen, B-1
	Detail Screen, B-2
	Realtime Display Screen, B-2
	Sample Manager Screen, B-3
	Rack (Patient) Screen, B-3
	Rack (Calibration) Screen, B-4
	Rack (QC) Screen, B-4
	STAT Status Screen, B-5
	STAT (Patient) Screen, B-5
	STAT (Calibration) Screen, B-6
	STAT (QC) Screen, B-6
	AUTO ACAL/QC Setup Screen, B-7
	Analyzer Maintenance Screen, B-7
	ISE Maintenance Screen, B-8
	Version Information Screen, B-8
	Calibrate the ISE Screen, B-9
	User Menu Screen, B-9
APPENDIX C:	End-User License Agreement and Open Source Software Notice, C-1
	End-user License Agreement, C-1
	Open Source Software Notice, C-4

Safety Notice

Read all product manuals and consult with Beckman Coulter-trained personnel before you operate the system. Do not perform any procedure before you carefully read all instructions. Always follow the product labels and the recommendation from the manufacturer. For more information, contact Beckman Coulter.

Alerts for Warning, Caution, Important, Note, and Tip

Warning

Warning indicates a potentially hazardous situation which, if not avoided, could cause death or serious injury. Warning can indicate the possibility of erroneous data that could cause an incorrect diagnosis.

Caution

Caution indicates a potentially hazardous situation which, if not avoided, can cause minor or moderate injury. Caution can also alert against unsafe practices, or indicate the possibility of erroneous data that could cause an incorrect diagnosis.

Important

Important indicates important information to follow.

Note

Note indicates notable information to follow.

Tip

Tip indicates information to consider.

Use Statement

- The system is for indoor use only.
- Use the system in a manner specified by Beckman Coulter, as the protection provided by the system can be impaired and incorrect results or system failure can occur.

Notice to Users

- In the unlikely event that a serious incident occurs with this product, we will notify the users and the administrative authorities of the country in writing.
- If a user discovers a serious incident, the user should contact a Beckman Coulter Representative.

Symbols Glossary

Table 1 Symbols Glossary





Symbol	Description
	<p>CE Marking</p> <p>This symbol indicates conformity with the provisions of the applicable EU directives.</p>
	<p>cNRTLus Certification Mark</p> <p>This symbol indicates recognition by a Nationally Recognized Testing Laboratory (NRTL) that the system has met the relevant product safety standards for the United States and Canada.</p> <p><i>OSHA, CEC</i></p>
<div style="border: 1px solid black; padding: 2px; display: inline-block;">Made in <i>Country of Origin</i></div>	<p>Country of Origin Symbol</p> <p>This symbol indicates the country that the product was manufactured in.</p>
	<p>Moving Parts Symbol</p> <p>This symbol indicates that there are moving parts in the area. Only operate the system when all covers are in position and use caution to reduce the risk of personal injury. While the system is operating, do not touch the moving parts of the system. Do not insert fingers or hands into any system opening.</p>
	<p>Warning; Crushing of hands</p> <p>This symbol indicates a warning of a closing motion of mechanical parts of equipment.</p> <p><i>ISO 7010. Graphical Symbols for electrical equipment in medical practices. #W024</i></p> <p>Supplemental Product-Specific Manufacturer Information</p> <p>Use caution to avoid injury to hands when close to equipment with moving mechanical parts.</p>
	<p>RCM Symbol</p> <p>This symbol indicates compliance with the Australian Communications Media Authority (ACMA) requirements (safety and EMC) for Australia and New Zealand.</p>

Table 1 Symbols Glossary (Continued)



Symbol	Description
	<p>RoHS Caution Symbol</p> <p>This symbol indicates that this electronic information product contains certain toxic or hazardous elements, and can be used safely during its environmental protection use period. The number in the middle of the logo indicates the environmental protection use period (in years) for the product. The outer circle indicates that the product can be recycled. The logo also signifies that the product should be recycled immediately after its environmental protection use period has expired. The date on the label indicates the date of manufacture.</p> <p>These labels and materials declaration table (the Table of Hazardous Substance's Name and Concentration) meet People's Republic of China Electronic Industry Standard SJ/T11364-2006 <i>Marking for Control of Pollution Caused by Electronic Information Products</i> requirements.</p>
	<p>RoHS Environmental Symbol</p> <p>This symbol indicates that the product does not contain any toxic or hazardous substances or elements. The e stands for electrical, electronic, and environmental electronic information products. This symbol indicates that this electronic information product does not contain any toxic or hazardous substances or elements, and is green and is environmental. The outer circle indicates that the product can be recycled. The symbol also indicates that the product can be recycled after being discarded, and should not be casually discarded.</p>
	<p>RxOnly Symbol</p> <p>This symbol is recognized by the US FDA as an alternative to the following statement: Caution: Federal law restricts this device to sale by or on the order of a licensed practitioner.</p> <p><i>21 CFR 801.109(b)(1)</i></p>

Table 1 Symbols Glossary (Continued)









Symbol	Description
	<p>Recycling Symbol</p> <p>This symbol is required by the Waste Electrical and Electronic Equipment (WEEE) Directive of the European Union. This symbol indicates that:</p> <ol style="list-style-type: none"> 1. The device was put on the European Market after August 13, 2005. 2. The device is not to be disposed of via the municipal waste collection system of any member state of the European Union. <p>Customers must understand and follow all laws regarding the correct decontamination and safe disposal of electrical equipment. For Beckman Coulter products bearing this label, contact your dealer or your local Beckman Coulter Representative for more information on the take-back program that facilitates the correct collection, treatment, recovery, recycling, and safe disposal of these products.</p> <p><i>EU Directive 2002-96-EC: waste electrical and electronic equipment (WEEE)</i></p> <p>For the Japan market:</p> <p>This system is considered an industrial waste, subject to special controls for infectious waste. Before disposal of the system, refer to the <i>Waste Disposal and Public Cleaning Law</i> for compliance procedures.</p>
	<p>"ON" (power)</p> <p>This symbol indicates connection to the mains, at least for mains switches or their positions, and all those cases where safety is involved.</p> <p><i>IEC 60417: Graphical symbols for use on equipment - Overview and application, #5007</i></p> <p>Supplemental Product-Specific Manufacturer Information</p> <p>This symbol indicates the on position.</p>
	<p>"ON"/"OFF" (push-push)</p> <p>This symbol indicates connection to or disconnection from the mains.</p> <p><i>IEC 60417: Graphical symbols for use on equipment - Overview and application, #5010</i></p> <p>Supplemental Product-Specific Manufacturer Information</p> <p>This symbol can also indicate a switch that is used as an on and off switch, without disconnecting power.</p>

Table 1 Symbols Glossary (Continued)

Symbol	Description
	<p>"ON" for a part of equipment</p> <p>This symbol indicates the On condition for a part of equipment.</p> <p><i>IEC 60417: Graphical symbols for use on equipment - Overview and application, #5264</i></p> <p>Supplemental Product-Specific Manufacturer Information</p> <p>This symbol can also indicate on or reset conditions.</p>
	<p>Stop</p> <p>This symbol indicates the control or the indicator to stop the active function.</p> <p><i>IEC 60417: Graphical symbols for use on equipment - Overview and application, #5110A</i></p> <p>Supplemental Product-Specific Manufacturer Information</p> <p>This symbol indicates a stop button.</p>
	<p>"OFF" (power)</p> <p>This symbol indicates disconnection from the mains, at least for mains switches or their positions, and all those cases where safety is involved.</p> <p><i>IEC 60417: Graphical symbols for use on equipment - Overview and application, #5008</i></p> <p>Supplemental Product-Specific Manufacturer Information</p> <p>This symbol indicates the off position.</p>
	<p>Fuse</p> <p>This symbol indicates fuse boxes or their location.</p> <p><i>IEC 60417: Graphical symbols for use on equipment - Overview and application, #5016</i></p> <p>Supplemental Product-Specific Manufacturer Information</p> <p>This symbol can also indicate a fuse location and rating.</p>
	<p>Dangerous voltage</p> <p>This symbol indicates hazards arising from dangerous voltages.</p> <p><i>IEC 60417: Graphical symbols for use on equipment - Overview and application, #5036</i></p> <p>Supplemental Product-Specific Manufacturer Information</p> <p>This symbol can also indicate an area of the system to not access under any circumstances, due to possibility of high voltages and the risk of electrical shock.</p>

Safety Notice
Symbols Glossary

Table 1 Symbols Glossary (Continued)













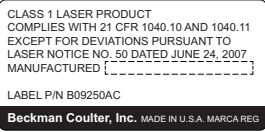
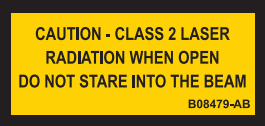

Symbol	Description
	<p>Protective earth; protective ground</p> <p>This symbol indicates a terminal which is intended for connection to an external conductor for protection against electric shock in case of a fault, or the terminal of a protective earth (ground) electrode.</p> <p><i>IEC 60417: Graphical symbols for use on equipment - Overview and application, #5019</i></p>
	<p>Warning, Hot Surface</p> <p>This symbol indicates a warning of a hot surface.</p> <p><i>ISO 7010. Graphical Symbols – Safety colors and safety signs. #W017</i></p> <p>Supplemental Product-Specific Manufacturer Information</p> <p>This symbol indicates that there is a hot surface or component (such as a lamp) in the area that, if touched, can cause a burn.</p>
	<p>Laser Compliance</p> <p>This symbol indicates that the product is a Class 1 Laser Product and is in compliance with international standard and US requirements.</p> <p><i>21 CFR 1040</i></p>
	<p>Laser Class 2 Panel Label</p> <p>This symbol on a panel indicates that there is Class 2 laser light radiation beyond the panel it is placed on. Use caution and do not stare into the beam when laser light is in the area.</p> <p><i>IEC 60825: Safety of laser products - Part 1: Equipment classification and requirements, clause 7.4</i></p>
	<p>Manufacturer</p> <p>This symbol indicates the medical device manufacturer.</p> <p><i>ISO 15223-1. Medical devices - Symbols to be used with medical device labels, labelling and information to be supplied - Part 1: General Requirements. #5.1.1</i></p> <p>Supplemental Product-Specific Manufacturer Information</p> <p>This symbol indicates who the legal manufacturer of the product is.</p>
	<p>Authorised representative in the European Community</p> <p>This symbol indicates the authorized representative in the European community.</p> <p><i>ISO 15223-1. Medical devices - Symbols to be used with medical device labels, labelling and information to be supplied - Part 1: General Requirements. #5.1.2</i></p>

Table 1 Symbols Glossary (Continued)

Symbol	Description
	<p>Catalogue Number</p> <p>This symbol indicates the manufacturer's catalogue number so that the medical device can be identified.</p> <p><i>ISO 15223-1. Medical devices - Symbols to be used with medical device labels, labelling and information to be supplied - Part 1: General Requirements. #5.1.6</i></p>
	<p>In vitro diagnostic medical device</p> <p>This symbol indicates a medical device that is intended to be used as an in vitro diagnostic medical device.</p> <p><i>ISO 15223-1: Medical devices. Symbols to be used with medical device labels, labelling and information to be supplied. General requirements, clause 5.5.1</i></p>
	<p>Caution</p> <p>This symbol indicates the need for the user to consult the instructions for use for important cautionary information such as warnings and precautions that cannot, for a variety of reasons, be presented on the medical device itself.</p> <p><i>ISO 15223-1. Medical devices - Symbols to be used with medical device labels, labelling and information to be supplied - Part 1: General Requirements. #5.4.4</i></p>
	<p>Warning; Biological hazard</p> <p>This symbol indicates a warning of a biological hazard.</p> <p><i>ISO 7010. Graphical Symbols - Safety colors and safety signs. #W009</i></p> <p>Supplemental Product-Specific Manufacturer Information</p> <p>This symbol indicates a caution to operate only with all covers in position to decrease risk of personal injury or biohazard.</p> <p>This symbol indicates the use of biohazardous materials in the area. Use caution when working with possible infectious samples.</p> <p>Wear Personal Protective Equipment (PPE) such as gloves, eye shields, and lab coats. Handle and dispose of biohazardous materials according to your laboratory procedures.</p>
	<p>Consult instructions for use</p> <p>This symbol indicates the need for the user to consult the instructions for use.</p> <p><i>ISO 15223-1. Medical devices - Symbols to be used with medical device labels, labelling and information to be supplied - Part 1: General Requirements. #5.4.3</i></p>

Safety Notice
Summary of Hazards

Table 1 Symbols Glossary (Continued)

Symbol	Description
	<p>Date of Manufacture</p> <p>This symbol indicates the date when the medical device was manufactured.</p> <p><i>ISO 15223-1. Medical devices - Symbols to be used with medical device labels, labelling and information to be supplied - Part 1: General Requirements. #5.1.3</i></p>
	<p>Serial number</p> <p>This symbol indicates the manufacturer's serial number so that a specific medical device can be identified.</p> <p><i>ISO 15223-1. Medical devices - Symbols to be used with medical device labels, labelling and information to be supplied - Part 1: General Requirements. #5.1.7</i></p>
	<p>Warning; Laser Beam</p> <p>This symbol indicates a warning of a laser beam.</p> <p><i>ISO 7010. Graphical Symbols - Safety colors and safety signs. #W004</i></p> <p>Supplemental Product-Specific Manufacturer Information</p> <p>This symbol indicates that there can be laser light radiation in the area. Take precautions to prevent exposure.</p>
	<p>California Proposition 65</p> <p>This symbol indicates that this product can expose you to chemicals known to the State of California to cause Cancer and Reproductive Harm. For more information go to https://www.P65Warnings.ca.gov.</p>

Summary of Hazards

This section describes the possible hazards of the system. The hazards of individual procedures in this manual are included in the warnings or cautions within the instructions. Read this section before you operate this system.

Follow the power requirements in the system specifications. Follow the procedures and safety warnings throughout this manual.

If you use the system in a manner not specified by Beckman Coulter, the protection provided by the system can be impaired and incorrect results or system failure can occur.

Bar Code Reader

Do not adjust or remove the housing of any bar code reader. The bar code readers use lasers and looking directly at the laser light can be hazardous. Assume that the laser is always on.

Use of control or adjustments or performance of procedures other than these specified herein may result in hazardous radiation exposure.

Biohazardous and Chemical Materials

Observe all biohazard precautions when doing maintenance, service, or troubleshooting on the system. Biohazard precautions include, but are not limited to, wearing gloves, eye shields, and lab coats, and washing hands after working on contaminated portions of the system.

Follow all laboratory procedures and policies for handling infectious and pathogenic materials.

Avoid skin contact with reagents and other chemical preparations. Wear Personal Protective Equipment (PPE) to work with reagents and other chemical preparations used with the system. For more information, refer to the related SDS (Safety Data Sheet).

Clean spills of biohazardous or other potentially hazardous substances on the system immediately. If the system must be decontaminated, contact Beckman Coulter.

Follow your laboratory procedure for biohazardous and hazardous material disposal.

Electric Shock

Do not replace or service any components where you can contact hazardous parts that can cause electric shock. Beckman Coulter must perform this maintenance. To completely power off the system, turn off the main breaker that is located on the left side of the analyzer module.

Electrical Ground

Never operate the system until the power cord is connected correctly to an electrical ground.

Electromagnetic Wave and Noise

The system generates, uses, and can radiate radio frequency energy. If the system is not installed and operated correctly, this energy can cause interference with other equipment. In addition, other equipment can radiate radio frequency energy to which the system is sensitive. If you suspect interference between the system and other equipment, Beckman Coulter recommends the following actions to correct the interference:

- This IVD medical equipment complies with the emission and immunity requirements described in this part of the EN/IEC 61326 series.
- As to emission, this system has been designed and tested to CISPR 11 Class A, so in a domestic environment, it may cause radio interference, in which case, you may need to take measures to mitigate the interference.
- It is recommended to evaluate the electromagnetic environment prior to operation of the system.
- Do not use this system in close proximity to sources of strong electromagnetic radiation (for example, unshielded intentional RF sources), as these can interfere with the proper operation.

Safety Notice

DxC 700 AU Hazards

- Do not use mobile or cordless telephones and transceivers in the same room as the system.
- Do not use medical equipment that can be susceptible to malfunctions caused by Electric Magnetic Field (EMF) near the system.

Flammable Materials

Do not use this system near flammable materials.

Moving Parts

While the system is in operation, do not touch or go close to any moving parts. Close protective guards and covers during operation. Failure to close covers correctly can cause injury or incorrect results.

Noise Level Generated by the Analyzer

60 dB

Liquid Waste

Handle all liquid waste as potentially infectious.

Some liquid waste can require special treatment before disposal. Follow your laboratory procedure.

Some substances in the reagents, control samples, calibrators, and wash solutions have disposal regulations. Follow your laboratory procedure.

Solid Waste

Handle all solid waste as potentially infectious.

Some solid waste can require special treatment before disposal. Follow your laboratory procedure.

Handle any used or replaced parts (such as tubing, mix bars, probes, cuvettes, and wash nozzles) as infectious waste materials. Follow your laboratory procedure.

DxC 700 AU Hazards

- A Beckman Coulter representative installs the system. If the system installation needs modification, contact Beckman Coulter.
- If the system malfunctions, power off the system completely using the main breaker located on the left side of the analyzer module before any repair service.
- If fluid is spilled on the system, turn off the main breaker located on the left side of the analyzer module immediately. Wipe up the spill only after turning off the main system breaker. If fluid enters the system after a spill, contact Beckman Coulter before restarting the system.

- Before transferring the analysis results to a Laboratory Information System, confirm that the sample numbers and sample IDs are correct.
- Substances such as Lipemia, Icterus, and Hemolysis can interfere with results. Refer to the reagent *Instructions for Use* (reagent IFU) for specific substance interference information.
- To be sure the analytical data is accurate:
 - Confirm the quality of deionized (DI) water is within specifications.
 - Confirm that all tests have passed calibration, and calibration is not expired.
 - Inspect the quality control data.
- Use the correct reagent, calibrator, and control to analyze samples.
- Avoid excessive reagent agitation, which can cause bubbles. If bubbles are visible on the surface of the reagent, remove them. Confirm that the reagent bottles are placed securely on the reagent tray with the correct adapters and partitions. If the bottles are tilted, incorrect results can occur, or you can damage the reagent probe.
- Prepare reagents, wash solutions, calibrators, and control samples according to the reagent IFU, paying particular attention to any reconstitution, mixing, and pretreatment instructions.
- Handling samples:
 - Precautions when using whole blood (HbA1c)
 - Use the HbA1c tab with the HbA1c reagent (for automated sample preparation) delivered from Beckman Coulter. Use of any other reagent can cause incorrect diagnostic results. Operation of the three tests 100.HbA1c, 101.T-Hb, and 102.A1c, and some of the specific test parameters are pre-programmed and you cannot change them.
 - If the blood has coagulated, obtain a new sample.
 - If the blood cells have precipitated, mix the whole blood by inverting gently.
 - Sample to sample carryover is one potential source of analytical error in the clinical laboratory. Do not use the same sample run on an AU Chemistry system for analysis of analytes for which a small quantity of carryover could cause problems with the results.
 - This system analyzes serum, urine, plasma, other sample types, and whole blood (for HbA1c only). Other refers to other body fluids such as cerebrospinal fluid (CSF). Some samples cannot be analyzed depending on the analysis test, reagent, and sample tubes used. For questions regarding reagent and sample tube type, contact Beckman Coulter.
 - Use serum or plasma that is clot free, or urine that is free from suspended matter. If serum or urine contains clots or suspended matter, the probe can clog and cause problems with the analysis results.
 - Chemicals present in the sample (medicine, anticoagulant, preservative, and so on) can significantly interfere with the results.
 - Highly viscous samples can interfere with the testing of the samples and the reliability of data.
 - Refer to the IFU for each test for correct sample collection and storage. Incorrect storage of samples can alter the analyte in a sample.
 - Use only sample containers and sample tubes specified by Beckman Coulter.
 - To reduce the risk of interference, centrifuge and then separate serum and plasma samples adequately from blood cells immediately. Before analysis, confirm that samples are free from suspended matter, such as fibrin. While the system has a sophisticated clot detection mechanism, this mechanism is not able to detect all clots. Carefully inspect the samples.

Safety Notice

Labels

- Collect urine samples using correct preservatives and remove any suspended matter using centrifugation before analysis (CLSI GP16-A2).
- Confirm that any anticoagulants or collection devices that employ a barrier are compatible with the test reagent being used. Refer to the reagent *Instructions for Use* for suitable and validated sample types. Use caution when using sample tubes containing barriers or gels. Confirm the suitability of all collection devices in use.
- For information about whether a serum separating agent is correct or not, contact the chemical reagent manufacturer or distributor.
- When using sample containers or tubes containing a separating medium, confirm that there is enough serum to avoid contaminating or blocking the sample probe with the separating medium.
- Confirm that there is enough sample for correct sampling to occur. The small amount of wash water left on the sample probe can dilute the volume of sample left in the sample tube.
- To prevent water leaks, confirm that Beckman Coulter has fitted water supply and drainage hoses according to local guidelines.
- To confirm system performance, maintain and inspect the system periodically by replacing the parts according to the instructions in this guide.
 - Have and follow a maintenance schedule for this system.
 - Create a maintenance routine for the computer software and hardware, including frequent backing up of data containing analysis settings, results history, and the event log list file.
 - Do not store backups onsite. Keep one copy on-site for reference and one copy offsite.
- Before using the system for the first time, set parameters for the reagent and sample quantity, measurement wavelength, calibrator values, and so on. Enter test specific parameters from the reagent setting sheet to have optimum system performance. Enter any updates to these settings into the system immediately.
- Dedicate the computer hardware to only running the system software. Do not connect the computer hardware to the Internet, unless instructed to do so by Beckman Coulter.
- Keep the analyzer covers closed except for startup procedures and maintenance. If the covers are open for extended periods of time, excess condensation can be generated in the reagent refrigerators and cause errors.
- Be sure all consumables are unopened before use. If the consumables appear to be opened or contaminated, contact Beckman Coulter.

Labels

- Stripes - Orange stripes affixed to the system surface indicate the movement areas of the hardware components. Avoid these areas during operation.
- Warning Labels - Identify areas of the system where hazards exist and where caution should be taken to avoid serious injury or death.
- Instruction Labels - Instruction labels are affixed on the system at relevant locations to alert the operator to operate the system correctly.

Fluorocarbons Recovery and Destruction Law Label

This system uses a Hydro FluoroCarbon (HFC) cooling medium.

HFC chemicals cannot be discharged indiscriminately. When the system is discarded, recover HFC chemicals.

The type, pressure, and volume of the HFC chemicals are described on the label.

Restricted Use

- Samples and reagents: Refer to the reagent Instructions for Use used for measurement.
- Consumables: Refer to Chapter 6 *Maintenance* in this IFU.
- Computer Connectivity (LIS, Automation, Pro Services): Refer to *System Overview > Hardware Overview > Computers* section.

DxC 700 AU Laser Labels

This system complies with IEC60825-1 and is classified as a Class 1 laser product.

Safety Notice
DxC 700 AU Laser Labels

Figure 1 Laser Labels

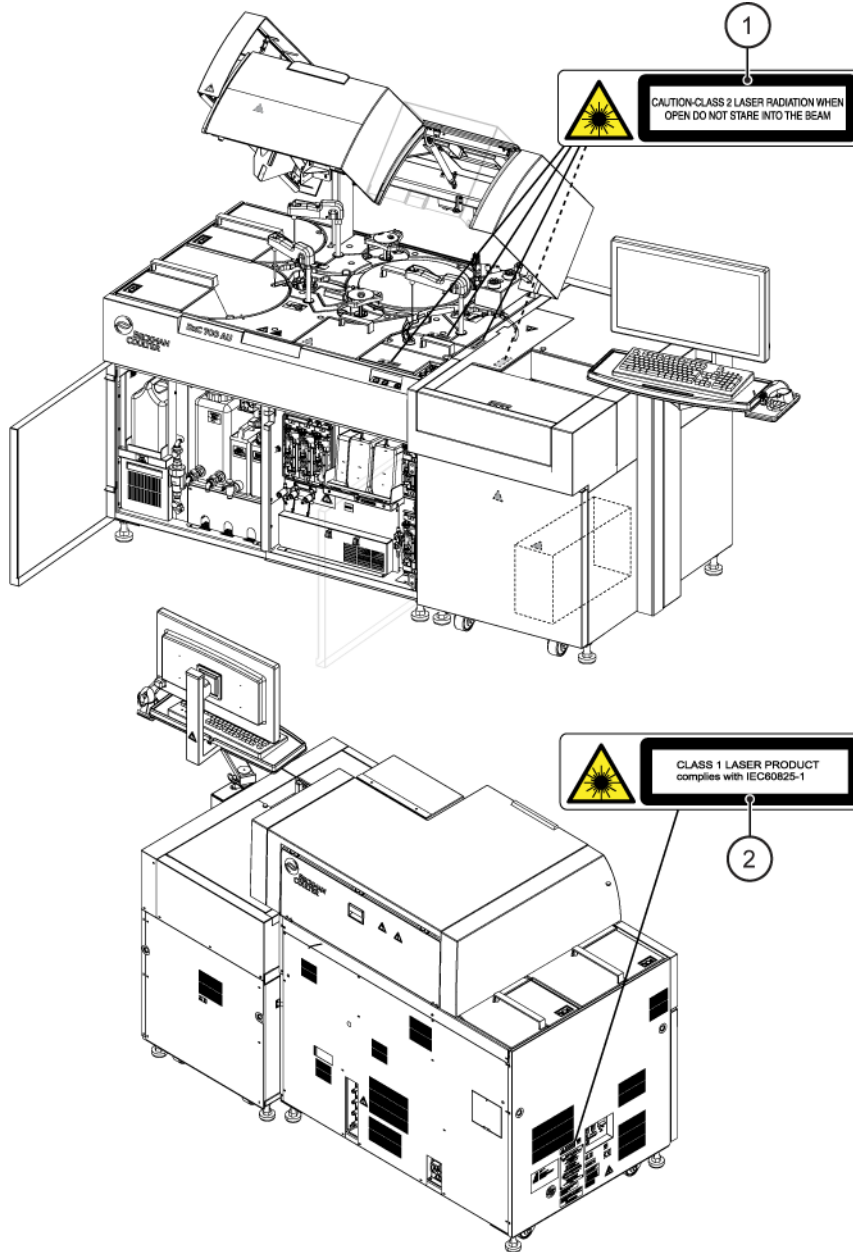

1. CAUTION-CLASS 2 LASER RADIATION
WHEN OPEN DO NOT STARE INTO THE
BEAM

2. CLASS 1 LASER PRODUCT complies with
IEC60825-1

Software Overview

Software Paths

A software path signifies a sequence of options that you select in the software interface in the indicated order.

This manual expresses software paths in the following format:

Select **Navigation Button** > **Screen** > **Tab**.

For example, [Figure 1.1 Software Paths](#) shows the path **Test Results** > **Reaction Monitor** > **Main**.

Figure 1.1 Software Paths

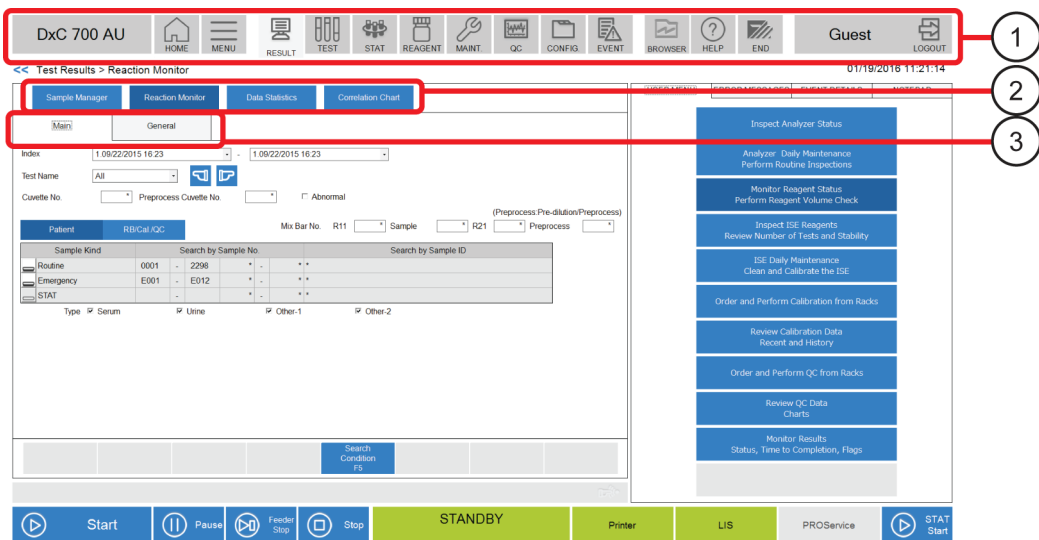

1. Navigation buttons

2. Screen buttons

3. Tab buttons

Organization and Functional Outline of Test Results Menu

Use this menu to manage the test results.

Table 1.1 Test Results Menu Options

Navigation Button	Screen
RESULT	<p>Sample Status</p> <p>View the status of the last 1,000 samples processed in the current index.</p> <p>Refer to the topic on the Sample Status screen in the <i>DxC 700 AU Instructions for Use</i>.</p> <p>Refer to Sample Status Screen.</p>
	<p>Detail</p> <p>View the results of the sample analysis in detail.</p> <p>Refer to the topic on the Sample Status screen in the <i>DxC 700 AU Instructions for Use</i>.</p> <p>Refer to Detail Screen.</p>
	<p>Realtime Display</p> <p>View the results of the sample analysis in real time.</p> <p>Refer to the topic on the Sample Status screen in the <i>DxC 700 AU Instructions for Use</i>.</p> <p>Refer to Realtime Display Screen.</p>
	<p>Sample Manager</p> <p>Display the Sample Manager screen.</p> <p>Refer to Sample Manager Screen.</p>
	<p>ISE Calibration</p> <p>Display the ISE Maintenance: Calibration tab (MAINT. > ISE Maintenance > Calibration).</p> <p>Refer to Organization and Functional Outline of Maintenance Menu.</p>
RESULT > Sample Manager	<p>Sample Manager</p> <p>Display analysis results, perform data correction, print data lists, and batch transfer data online.</p> <p>Refer to Sample Management.</p>
	<p>Reaction Monitor</p> <p>View information about reaction processes of analysis results.</p> <p>Refer to Display Reaction Monitor.</p>

Table 1.1 Test Results Menu Options (Continued)

Navigation Button	Screen
	<p>Data Statistics</p> <p>View key statistics of patient sample results and the results of a test within one index as bar charts.</p> <p>Refer to View Data Statistics.</p>
	<p>Correlation Chart</p> <p>View a correlation chart.</p> <p>Refer to Create a Correlation Chart.</p>

Organization and Functional Outline of Sample Program Menu

Use this menu to order tests for samples from racks.

Table 1.2 Sample Program Menu Options

Navigation Button	Screen
TEST	<p>Rack (patient)</p> <p>Order tests and demographics for patient samples manually.</p> <p>Refer to the topic on ordering for routine and emergency samples in the <i>DxC 700 AU Instructions for Use</i>.</p> <p>Refer to Rack (Patient) Screen.</p>
	<p>Rack (Calibration)</p> <p>Order tests for calibrators.</p> <p>Refer to the topic on ordering and performing calibration from the racks in <i>DxC 700 AU Instructions for Use</i>.</p> <p>Refer to Rack (Calibration) Screen.</p>
	<p>Rack (QC)</p> <p>Order tests for control samples.</p> <p>Refer to the topic on ordering and performing quality control (QC) from the racks in <i>DxC 700 AU Instructions for Use</i>.</p> <p>Refer to Rack (QC) Screen.</p>

Organization and Functional Outline of STAT Menu

Use this menu to view the STAT status, order tests from the STAT table, and program the parameters for STAT table analysis.

Table 1.3 STAT Menu Options

Navigation Button	Screen
STAT	<p>STAT Status</p> <p>View the status of the STAT table and start STAT sample analysis.</p> <p>Refer to the topic on priority STAT samples in the <i>DxC 700 AU Instructions for Use</i>.</p> <p>Refer to STAT Status Screen.</p>
	<p>STAT (Patient)</p> <p>Order tests and demographics manually for patient samples for STAT table analysis.</p> <p>Refer to the topic on entering manual orders for priority STAT samples in the <i>DxC 700 AU Instructions for Use</i>.</p> <p>Refer to STAT (Patient) Screen.</p>
	<p>STAT (Calibration)</p> <p>Order tests for calibrators for STAT table analysis.</p> <p>Refer to the topic on ordering and performing calibration from the STAT table in the <i>DxC 700 AU Instructions for Use</i>.</p> <p>Refer to STAT (Calibration) Screen.</p>
	<p>STAT (QC)</p> <p>Order tests for control samples for STAT table analysis.</p> <p>Refer to the topic on ordering and performing quality control (QC) from the STAT table in the <i>DxC 700 AU Instructions for Use</i>.</p> <p>Refer to STAT (QC) Screen.</p>
	<p>AUTO ACAL/QC Setup</p> <p>Program the parameters for automatic ACAL and QC on the STAT table.</p> <p>Refer to AUTO ACAL/QC Setup Screen.</p>

Organization and Functional Outline of Reagent Menu

Use this menu to view the quantity of photometric and ISE tests onboard, monitor the status of photometric and ISE reagents onboard, confirm reagent volumes, and load reagents in *MEASURE* mode.

Table 1.4 Reagent Menu Options

Navigation Button	Screen
REAGENT	<p>Reagent Management</p> <p>Inspect the quantity of reagent and the quantity of tests available in a bottle.</p> <p>Refer to Reagent Management.</p>
	<p>Reagent Inventory</p> <p>A calculation of the volume or tests of R1 and R2 (for each reagent) used for each day of the week for a specified timeframe.</p> <p>Refer to Reagent Inventory.</p>
	<p>Reagent Consumption</p> <p>A breakdown of reagent used for a specified timeframe by volume or tests of R1 and R2 by each rack type.</p> <p>Refer to Reagent Consumption.</p>
	<p>Rack (Calibration)</p> <p>Perform calibration orders for calibration analysis from racks.</p> <p>Refer to the topic on ordering and performing calibration from the racks in the <i>DxC 700 AU Instructions for Use</i>.</p> <p>Refer to Rack (Calibration) Screen.</p>
	<p>STAT (Calibration)</p> <p>Perform calibration orders for calibration analysis from the STAT table.</p> <p>Refer to the topic on ordering and performing calibration from the STAT table in the <i>DxC 700 AU Instructions for Use</i>.</p> <p>Refer to STAT (Calibration) Screen.</p>

Organization and Functional Outline of Maintenance Menu

Use this menu to monitor and perform analyzer and ISE maintenance, save and load parameters, review the system software versions, and perform diagnostic functions.

Table 1.5 Maintenance Menu Options

Navigation Button	Screen
MAINT.	<p>Analyzer Maintenance</p> <p>View the maintenance schedule and perform maintenance procedures.</p> <p>Refer to the topic on accessing maintenance operations in the <i>DxC 700 AU Instructions for Use</i>.</p> <p>Refer to Analyzer Maintenance Screen.</p>
	<p>ISE Maintenance</p> <p>View the maintenance schedule of the ISE module and perform ISE maintenance procedures.</p> <p>Refer to the topics on ISE maintenance in the <i>DxC 700 AU Instructions for Use</i>.</p> <p>Refer to ISE Maintenance Screen.</p>
	<p>File Management</p> <p>Save and load parameters to internal hard disk or external memory media.</p> <p>For more information, refer to Save or Load Parameters.</p>
	<p>Version Information</p> <p>View the system software versions.</p> <p>Refer to Version Information Screen.</p>

Organization and Functional Outline of Quality Control Menu

Use this menu to display and edit the results and history for quality control.

Table 1.6 Quality Control Menu Options

Navigation Button	Screen
QC	<p>Chart</p> <p>View the QC data variation within the same or between index dates as a daily chart or a day-to-day chart.</p> <p>Refer to Monitor the QC Using the Daily Variation Chart.</p>
	<p>Twin Plot Chart</p> <p>View the QC data variation of two control samples as a twin plot chart.</p> <p>Refer to Monitor the QC Using the Twin Plot Chart.</p>

Table 1.6 Quality Control Menu Options (Continued)

Navigation Button	Screen
	<p>QC Setup</p> <p>Program the control materials and QC check protocols.</p> <p>Refer to QC Setup Menu.</p>

Organization and Functional Outline of Calibration Menu

Use this menu to display a history of calibration information and perform calibration verification.

Table 1.7 Calibration Menu Options

Navigation Button	Screen
MENU > Calibration	<p>Calibration Monitor</p> <p>View the current reagent blank and calibration status and a history of the reagent blank and calibration data on a graph.</p> <p>Refer to Monitor the Reagent Blank and Calibration.</p>
	<p>ISE Calibration</p> <p>Confirm the ISE calibration results.</p> <p>Refer to the topic on calibrating the ISE in the <i>DxC 700 AU Instructions for Use</i>.</p> <p>Refer to Calibrate the ISE Screen.</p>
	<p>Calibration Setup</p> <p>Program calibrators, calibration parameters, and ISE parameters.</p> <p>Refer to Calibration Setup Menu.</p>

Organization and Functional Outline of Configuration Parameters Menu

Use this menu to program test parameters, calibration parameters, quality control parameters, system condition parameters, online conditions, sample program format, and list formats.

Table 1.8 Configuration Parameters Menu Options

Navigation Button	Screen
CONFIG.	<p>Test Name Parameters</p> <p>Program basic parameters such as test name and reagent ID.</p> <p>Refer to Test Name Parameters Screen.</p>
	<p>Panel</p> <p>Program panels for patient samples, reagent blank, calibration, and QC.</p> <p>Refer to Panel Screen.</p>
	<p>Group of Tests</p> <p>Assign tests to a Group. You can program a maximum of three Groups of tests. You can program a maximum of 60 photometric tests and 3 ISE tests in a Group.</p> <p>Refer to Group of Tests Screen.</p>

Table 1.8 Configuration Parameters Menu Options (Continued)

Navigation Button	Screen
CONFIG.	<p>Test Volume and Methods</p> <p>Program detailed parameters for tests (in the General, LIH, ISE, HbA1c, Calculated Tests, and Range tabs).</p> <ul style="list-style-type: none"> • General Program detailed parameters for general test items. Refer to Test Volume and Methods: General Tab. • LIH (Serum Index) Program detailed parameters for the Lipemia/Icterus/Hemolysis test. Refer to LIH Tab. • ISE Program detailed parameters for the ISE tests. Refer to Test Volume and Methods: ISE Tab. • HbA1c Program detailed parameters for the Whole Blood HbA1c test. Refer to HbA1c Tab. • Calculated Tests Program detailed parameters for calculated tests. Refer to Calculated Tests Tab. • Range Program parameters for the reference interval. Refer to Range Tab.
CONFIG.	<p>Rerun Test Parameters</p> <p>Program the rerun decision limits, reflex limits, and the rerun dilution rate for individual tests. Refer to Rerun Test Parameters Screen.</p> <hr/> <p>Rerun Check Parameters</p> <p>Program the common parameters for a rerun analysis (in the Flag and Reflex tabs). Refer to Rerun Check Parameters Screen.</p>

Table 1.8 Configuration Parameters Menu Options (Continued)

Navigation Button	Screen
	<p>Calibration Setup Program calibrators, calibration parameters, and ISE parameters. Refer to Calibration Setup Menu.</p> <p>QC Setup Program the control materials and QC check protocols. Refer to QC Setup Menu.</p> <p>Checked Tests Program parameters for logic checked tests. Refer to Checked Tests Screen.</p> <p>Contamination Parameters Program parameters to prevent contamination of tests. Refer to Contamination Parameters Screen.</p> <p>Data Check Parameters Program parameters for data check, such as diagnosis of prozone. For more information, contact Beckman Coulter. Refer to Prozone Check Tab.</p> <p>Analysis Mode Program the sample identification mode, bar code definition, auto or manual rerun, and other system parameters. Refer to Analysis Mode Screen.</p>
CONFIG.	<p>System Setup Program the language, offline format, sample type name, date format, date and time, and other type name. Refer to System Setup Screen.</p> <p>Program the Logon Program the logon conditions (in the User Setting, Security, and Access Level tabs). Refer to Program the Logon.</p>

Table 1.8 Configuration Parameters Menu Options (Continued)

Navigation Button	Screen
	<p>Comment Master</p> <p>Program the comments and symbols of unit.</p> <p>Refer to Comment Master Screen.</p>
	<p>User Menu</p> <p>Beckman Coulter pre-programs USER MENU in order of a typical operating workflow. Select CONFIG. > User Menu to edit pre-programmed menus.</p> <p>Refer to the topic on Program a User Menu in the <i>DxC 700 AU Instructions for Use</i>.</p> <p>Refer to User Menu Screen.</p>
	<p>Online</p> <p>Program the parameters for online communication between a Laboratory Information System (LIS) and the DxC 700 AU.</p> <p>Refer to Online Menu.</p>
	<p>Sample Program Format</p> <p>Program the sample order format, patient information format, and data output at analytical measuring range error.</p> <p>Refer to Sample Program Format Screen.</p>
	<p>List Format</p> <p>Program the common format parameters for printing the pending list, test summary, and reports.</p> <p>Refer to List Format Screen.</p>

 **Note**

If the DxC 700 AU connects to the Laboratory Automation System, the system uses rerun parameters from the LIS, not the parameters set in the Rerun Test Parameters or Rerun Check Parameters screens.

Principles of Analysis

This system performs automated analysis of serum, urine, plasma, other sample types, and whole blood (for HbA1c only). It measures sample components and automatically generates results.

This section provides an overview of how the DxC 700 AU tests samples. It also describes the ISE measuring method.

Reagent Blank

To calculate a measurement value (reaction OD), the system subtracts the reagent blank OD (reagent OD at each photometric point of P0 to P27) and the Deionized (DI) water blank OD values (photocal data) from the measured OD of a sample reacted with a reagent.

By performing a reagent blank measurement, the system obtains reagent blank OD values (RB) at all photometric points shown in the following chart.

You measure reagent blanks in blue racks. You can program position 1 and position 2 of the blue racks for serum, urine, other-1, other-2, and whole blood in the Calibration Setup: Calibrators tab (**CONFIG.** > Calibration Setup > Calibrators). Typically, you program position 1 for serum, urine, other-1, other-2, and whole blood, and you do not use position 2. Place the sample (deionized water) in position 1 of the blue rack.

The system measures up to four replicates of the sample and determines the reagent blank data (reagent blank OD value).

- 1 replicate: the OD value.
- 2 replicates: the mean value of two OD values.
- 3 replicates: the mean value of the two closest OD values.
- 4 replicates: discard the highest and lowest OD values and average the two remaining OD values.

Figure 1.2 Reagent Blank (Compared with Water Blank; Example of 2-step Analysis)

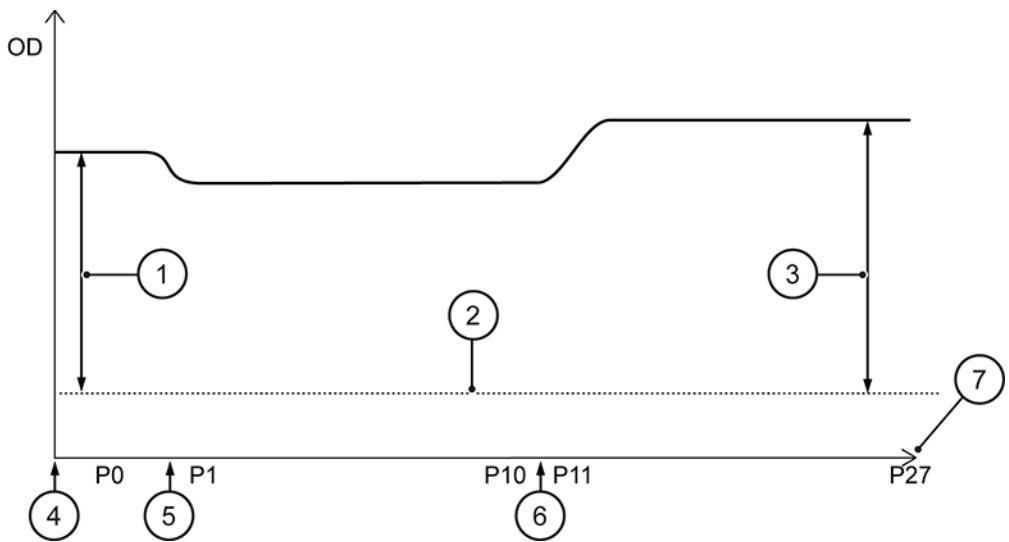

- | | |
|-----------------------------------------------------|-----------------------------------|
| 1. Reagent OD value at the first point (first data) | 4. R1 (first reagent) dispensing |
| 2. Deionized water blank (photocal data) | 5. Sample (water) dispensing |
| 3. Reagent OD value at the last point (second data) | 6. R2 (second reagent) dispensing |
| | 7. Photometric point |

First-point Reagent OD Value (First Data)

- First-point reagent OD value (RB) = {first point measured OD value} - {DI water blank (photocal data)}.
- If the first-point reagent OD value is outside the reagent OD range that you have programmed in **Reagent OD Limit 1st** of the Test Volume and Methods: General tab (**CONFIG. > Test Volume and Methods > General**), the system adds a flag y (for over range) or u (for under range) to the data.

Last-point Reagent OD Value (Second Data)

- Last-point reagent OD value (RB) = {last point measured OD value} - {DI water blank (photocal data)}.
- If the last-point reagent OD value is out of the reagent OD range that you have programmed in **Reagent OD Limit Last** of the Test Volume and Methods: General tab (**CONFIG. > Test Volume and Methods > General**), the system adds a flag Y (for over range) or U (for under range) to the data.

End Point Assays

1-Point Assay

This general end point assay determines the reaction mixture OD from the OD measured at a specified photometric position.

$$\text{Reaction mixture OD} = \text{OD (at specified position)} - \text{OD0 (at position 0)}$$

Figure 1.3 Reaction Curve for 1-Point End-Point Assay

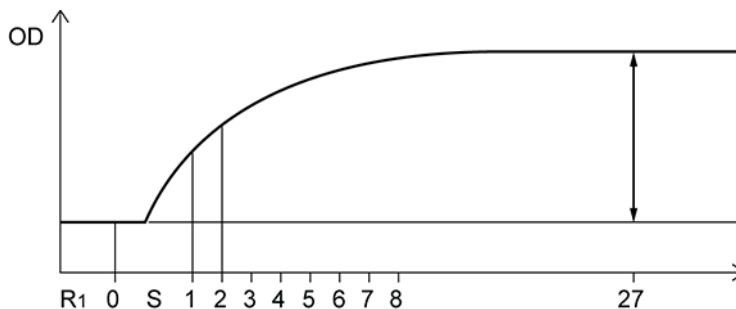

2-Point Assay (Self-Blank Method)

This end point assay requires a sample blank adjustment. Eliminate the OD values before dispensing the reagent 2 as the blank channel. To obtain correct data without influences from turbidity or color of the serum, the OD values of the blank channel are subtracted from the OD values measured after dispensing the reagent 2.

The following expression represents the OD value in this assay:

$$K2 = \{R1.V / (R1.V + R2.V + S.V)\}$$

$$K3 = \{(R1.V + S.V) / (R1.V + R2.V + S.V)\}$$

$$\text{Reaction OD value} = (Px - K2 \times P0) - (K3 \times Pz - K2 \times P0).$$

This calculation result is defined as the reaction OD value.

Figure 1.4 Reaction Curve for 2-Point End Point Assay (Self-Blank Method)

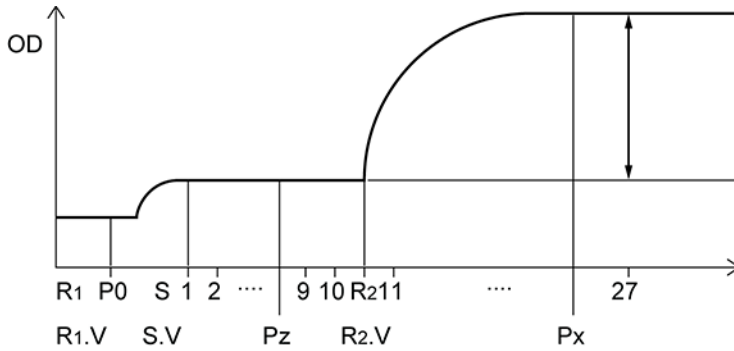

Table 1.9 2-Point Assay (Self-Blank Method)

Item	Description
R1.V:	Reagent 1 dispense volume
R2.V:	Reagent 2 dispense volume
S.V:	Sample dispense volume
P0:	OD value at the first point
Pz:	OD value before dispensing reagent 2
Px:	OD value after dispensing reagent 2

End Assay (Sample Blank Correction)

This type of assay uses two cuvettes, a cuvette for the color reaction and a cuvette for the sample blank. The system measures blank item OD values, which include serum quality issues, first. Then, the system subtracts the blank item value from the measured OD value of the actual sample (OD value of the color item).

With this end assay (sample blank correction), you can obtain higher accuracy data than the 2-point assay even when you cannot avoid serum quality issues (dotted line in [Figure 1.5 Reaction Curve for End Point Assay \(Sample Blank Correction\)](#)).

$$\text{Reaction OD value} = [\text{Color item OD value (OD}_C\text{)}] - [\text{Blank item OD value (OD}_B\text{)}]$$

Figure 1.5 Reaction Curve for End Point Assay (Sample Blank Correction)

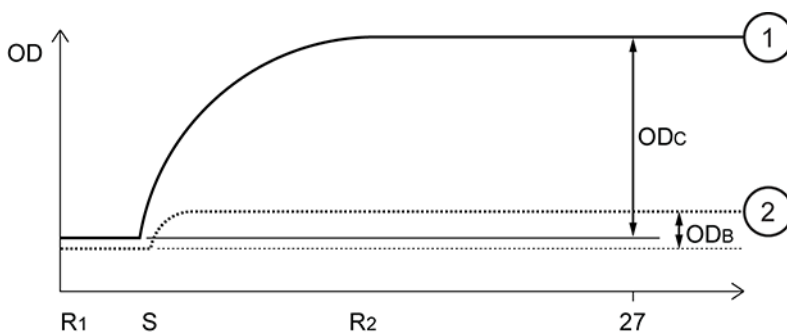

1. Color reaction channel
2. Sample blank channel

Rate Assays

Rate Assay

This assay determines the rate of absorbance variation per minute by calculating the average of the absorbance variations (ΔOD) between photometric points using the least squares method.

Figure 1.6 Reaction Curve for Rate Assay

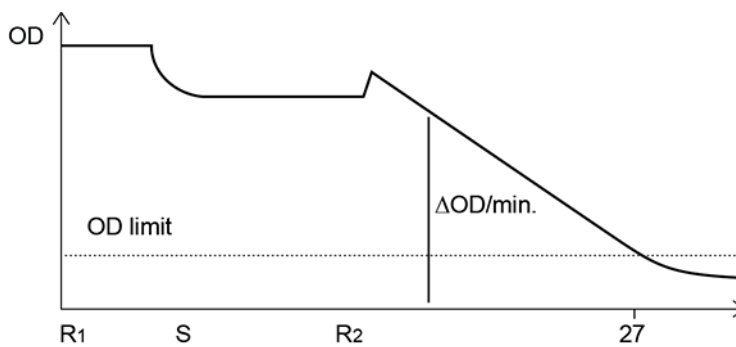

Double Rate Assay

This assay determines the rate of absorbance variation per minute by calculating the average of the absorbance variations (ΔOD) between photometric points using the least squares method. Next, the system obtains the OD rate of the objective substance from the calculation expression.

Figure 1.7 Reaction Curve for Double Rate Assay

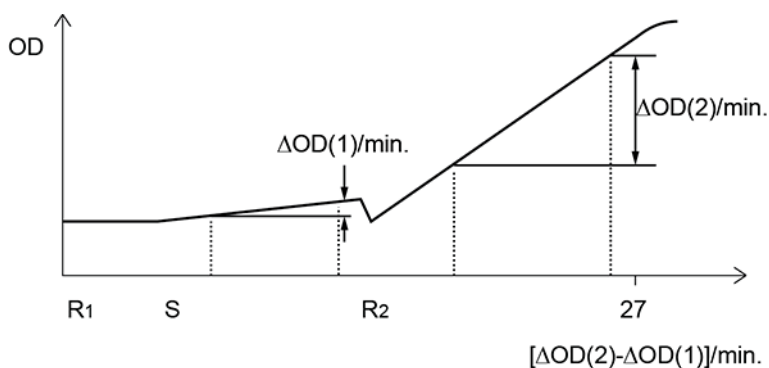

Fixed Point Assay

A fixed point assay measures the OD value at two specified photometry points. The system measures the two photometry points after the beginning of reaction between sample and reagent.

$$\text{Reaction OD value} = OD_B - OD_A$$

Figure 1.8 Reaction Curve for Fixed Point Assay

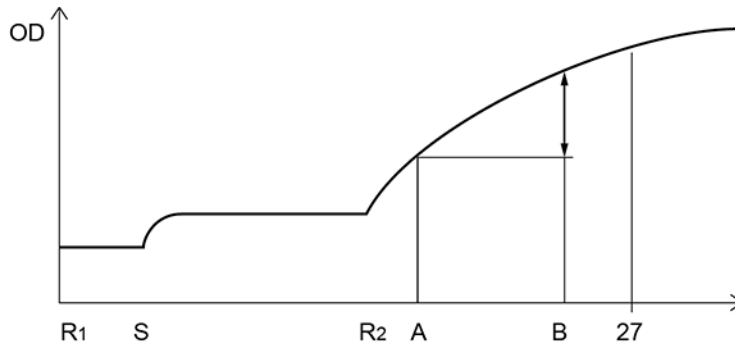

Quality Control

You can use many quality control techniques to monitor analyzer accuracy.

The analyzer software uses single rule, multi-rule, and twin plot QC evaluation.

- Single rule is the most common technique.
- Use multi-rule to prevent notification of insignificant errors.
- Use twin plot for easier classification of systematic and random errors.

For more information, refer to [Monitor QC](#).

Twin Plot Control

Evaluate quality controls with normal level expected values and abnormal level expected values together.

Figure 1.9 Twin Plot Chart

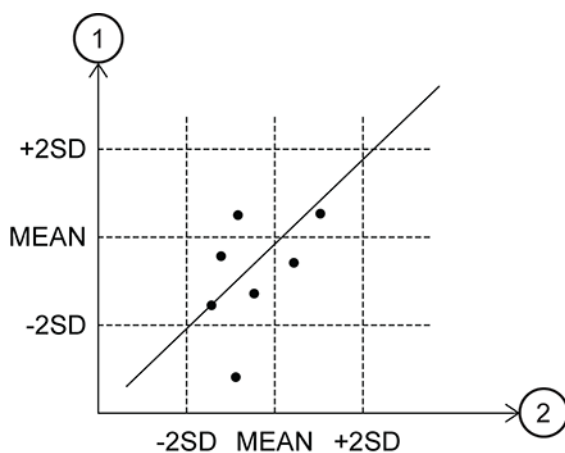

1. Abnormal control
2. Normal control

If both the normal and abnormal level samples fall below their lower control limits or both exceed their upper control limits, confirm the calibration system to determine systematic errors.

If only the abnormal level sample falls below the lower control limit, you can suspect a reagent problem. The twin plot control technique offers the advantage of classification of a systematic error or a random error.

Multi-Rule Control

In the day-to-day control, you confirm a control error by examining the control chart, but it is difficult to do confirmation of numerous tests on a real-time basis. With the multi-rule control technique, you can speedily cope with an error real-time, as this control technique identifies the rule out of range from a specific flag.

With this control technique, you must prepare a normal and abnormal level control.

Figure 1.10 Standard of Judgment from the Multi-Rule Shewhart Technique (Logic Diagram Applicable to Control Rules)

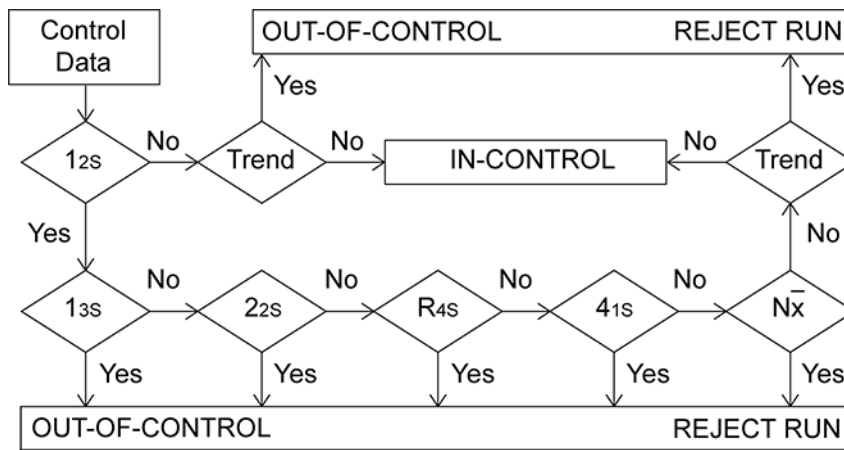

Symbols for Multi-Rule Control and Logic

The following describes the symbols for multi-rule control and logic:

- 1_{2s} is a judgment level for determining if one piece of control exceeds the control limit determined as 'MEAN ± 2 SD'. If they do not exceed the control limit, the system makes an inquiry to 1_{3s} for the next judgment level. If one piece of control exceeds the control limit, it is judged that the system has not correctly attained quality control.
- 1_{3s} is a judgment level for determining if one piece of control exceeds the control limit determined as 'MEAN ± 3 SD'. If they do not exceed the control limit, the system makes an inquiry to 2_{2s} for the next judgment level. If one piece of control exceeds the control limit, it is judged that the system has not correctly attained quality control.
- 2_{2s} is a criteria level for judging whether the two continuous pieces of control data exceed the control limit determined as 'MEAN ± 2 SD' in one direction. If they do not exceed the control limit, the system makes an inquiry to R_{4s} for the next judgment level. If they exceed the control limit, it is judged that the system has not correctly attained quality control.

 **Note**

The term *continuous* can have the following meanings:

- To be continuous in both directions for one identical control substance.
- To have continuity of high concentration and low concentration between control substances.
- R_{4S} is a judgment level for determining whether either of two continuous pieces of data with high and low concentrations exceeds the control limit specified as 'MEAN + 2SD' and whether the other exceeds the control limit of 'MEAN - 2SD'. In other words, it judges whether the two continuous pieces of data exceed 4SD in the same range. If the data is within the control limit, judgment advances to the next judgment level, 4_{1S} . If the data is outside of the control limit, the system has not correctly attained quality control.
- 4_{1S} is a judgment level for determining whether four continuous pieces of control data exceed the control limit of either 'MEAN +1 SD' or 'MEAN -1 SD'. If they do not exceed either control limit, the system makes an inquiry to the next judgment standard N_x for necessary judgment, but if they exceed the limit, the system has not correctly attained quality control.
- N_x is a judgment level for determining whether continuous N (7 to 10) pieces of control data are above or below the control mean. If the controls do not exceed the control limit, quality control has been correctly attained. If the controls exceed the control limit, quality control has not been correctly attained. The N_x rule uses a maximum of 10 pieces of previous data for judgment.
- Trend evaluates if 4 to 10 sequential results of measurement of the same control material are increasing or decreasing.

If exceeding one of the six multi-rule controls generates an error, the system attaches a flag to the control data.

Table 1.10 Multi-Rule Control Limit, Flag, and Cause of Error

Control Limit	Flag	Cause of Error
Exceeds 1_{3S}	2Q	Random error
Exceeds 2_{2S}	3Q	Systematic error
Exceeds R_{4S}	4Q	Random error
Exceeds 4_{1S}	5Q	Systematic error
Exceeds N_x	6Q	Systematic error
Trend abnormality	7Q	Increase or decrease in continuous quality control data

Control Errors Example

The following charts show control errors according to the multi-rule control:

Figure 1.11 Control Errors Example

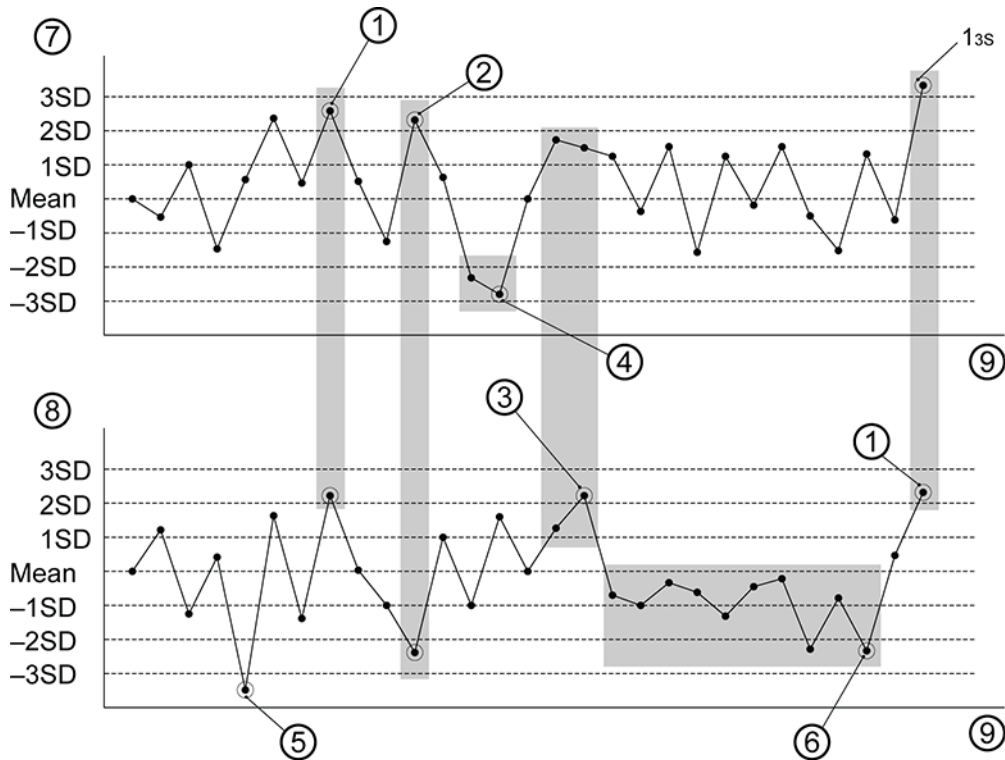

1. 2_{2S} : Systemic error. The high and low value controls both exceed the 2 SD level in one direction. The system generates a 3Q flag.
2. R_{4S} : Random error. The high value control exceeds the 2 SD level and the low value control exceeds the -2 SD level. The system generates a 4Q flag.
3. 4_{1S} : Systemic error. Four continuous QC results exceed the 1 SD level in one direction. The system generates a 5Q flag.
4. 2_{2S} : Systemic error. The high value control had two continuous results over 2 SD or under -2 SD in one direction. The system generates a 3Q flag.
5. 1_{3S} : Random error. One result is either over 3 SD or under -3 SD. The system generates a 2Q flag.
6. N_x : Systemic error. Ten continuous results are below the mean. The system generates a 6Q flag.
7. High value control
8. Low value control
9. Day

The following text describes the possible errors and causes for the random errors and systematic errors shown in [Figure 1.11 Control Errors Example](#). To troubleshoot the errors, refer to the following information:

For the random errors:

- Dispensing accuracy error (sample or reagent): Poor syringe (sample, reagent) dispensing accuracy because of syringe integrity problems or incorrect installation, air introduced into the plumbing system, dirty probes, empty reagents, and so on.
- Poor photometer accuracy: Lamp deterioration.
- Reagent degeneration: Incorrect reagent storage or contamination.
- Poor quality control sample: Incorrect sample, different lot, and so on.
- Insufficient cleaning: Mix bar cleaning incorrect or insufficient.

- Poor mixing: Mix bar component defective, incorrect mix bar used, cuvette wheel defective.

For the systematic errors:

- Incorrect calibration: Incorrect reconstitution of calibrators.
- Deteriorated reagent: Reagent degeneration, different lot, and so on.
- Temperature: Incorrect temperature control.

Summary of Calibration Types

You can generate a maximum of 15 types of calibration curves. The following information describes the six major types of calibration curves.

Figure 1.12 ACAL AA

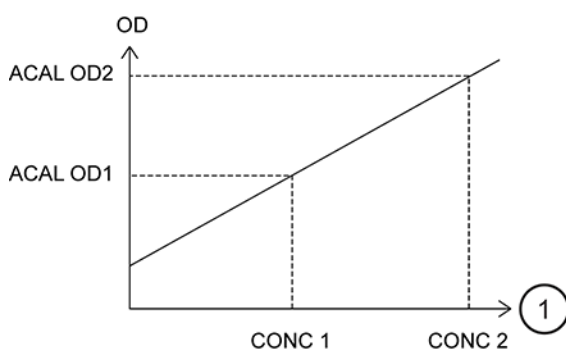

1. CONC: Calibrator Concentration value

- Generate this calibration curve using two different calibrators. The Y intercept is above or below 0 but does not pass through 0 (reagent blank).
- Use this type of calibration curve for fixed point assays.

Figure 1.13 ACAL AB

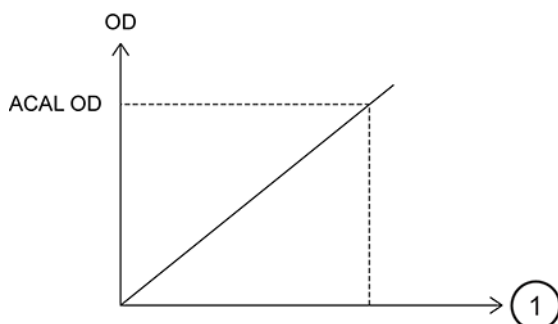

1. CONC: Calibrator Concentration value

- Generate this calibration curve using a single calibrator and the reagent blank. The Y intercept passes through 0.
- Use this type of calibration curve for end point assays. An example of a test using this type of calibration is Glucose.

Figure 1.14 ACAL 7AB

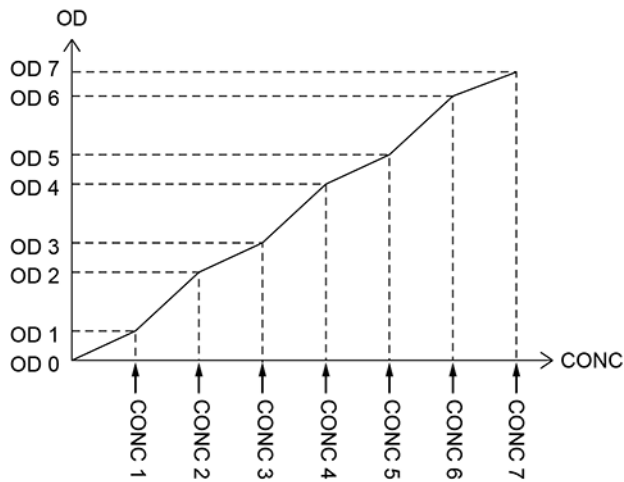

- Generate this calibration curve using a minimum of two calibrators up to a maximum of 7 calibrators. The Y intercept passes through 0.
- Use this type of calibration curve for immunoturbidimetric assays. An example of a test using this type of calibration is C-Reactive Protein.

Figure 1.15 MCAL MB

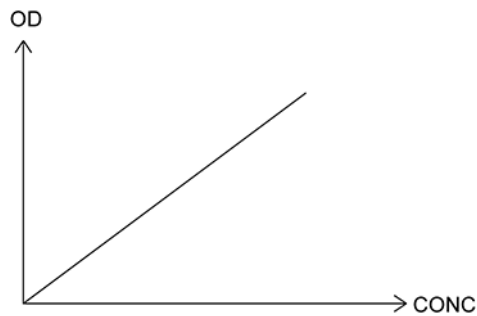

- Set the calibration coefficient with a theoretical or traceable reference method.
- MB factor derived from extinction coefficient or IFCC reference labs that is a derived factor.
- An example of a test using this type of calibration is Lactate Dehydrogenase.

Figure 1.16 MCAL 7 MB

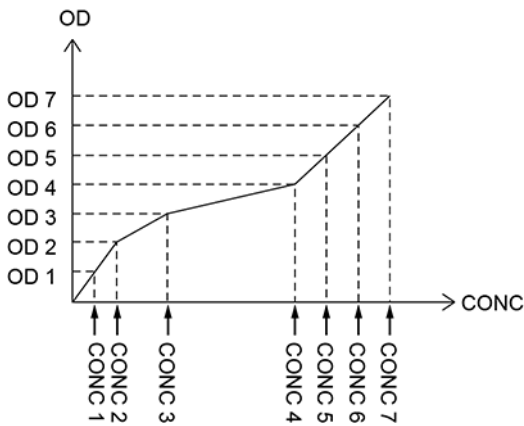

- Generate this calibration curve by entering the OD and concentration for a maximum of 7 calibrators.
- Use this type of calibration curve for immunoturbidimetric tests with constantly curving characteristics.

ACAL nAB (single-point correction)

First, analyze one of multiple standard solutions for 2AB to 7AB. By using the ratio between the reaction OD values of this standard solution and the previously measured standard solution, correct the reaction OD values of other standard solutions, and then recreate the calibration chart.

You can correct the calibration chart with two points of OD0 and another OD value, if the standard solution with a concentration of 0 is available.

Example 1: If none of multiple standard solutions has a concentration of 0.

Figure 1.17 Single-point Correction without a Standard Solution Concentration of Zero

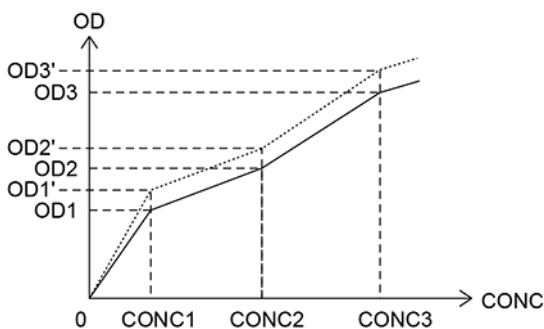

You can perform a single point update to the calibration curve for calibrations defined as 2AB to 7AB. A single calibrator is used to obtain a new reaction OD. The ratio between the previously obtained OD and the current OD causes the OD of the other calibrators to be adjusted, and the new calibration curve is calculated.

1. Perform the single-point correction.

$$ODn' = ODn \times \frac{OD2'}{OD2}$$

2. Recalculate for the calibration curve.

Example 2: If any standard solution has a concentration of 0.

Figure 1.18 Single-point Correction with a Standard Solution Concentration of Zero

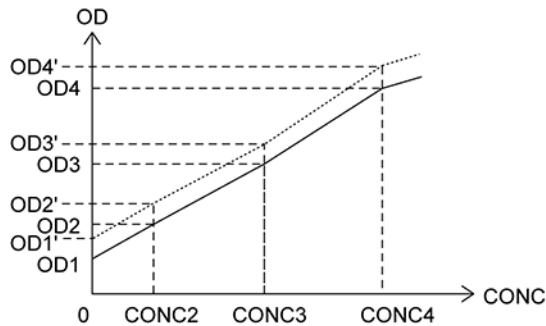

ODn: previous OD value ODn': OD value after correction

If you perform a correction with two points of CONC1 and another (CONC3), execute the following calculation.

1. Use the reaction OD values of CONC1 and CONC3 (OD1' and OD3') as they are.
2. Correct each point:

$$ODn' = \alpha \times (ODn - OD1) + \beta$$

$$\alpha = \frac{OD3' - OD1'}{OD3 - OD1}$$

$$\beta = OD1'$$

Principles of the Real-time Water Blank Check

The real-time water blank check method compares the water blank reading obtained during analysis to the previous water blank reading. If the deviation in the water blank reading on a cuvette exceeds a tolerance level, the system generates a **PHOTOMETRY ERROR DURING CUVETTE WASH** event.

The system generates a **PHOTOMETRY ERROR DURING CUVETTE WASH** event when it detects a cuvette overflow or unstable photometry. The following conditions can cause unstable photometry:

- Incorrectly placed cuvettes in the cuvette wheel
- Dirty cuvettes
- Insufficient amount of wash solution being supplied to clean the cuvettes
- A deteriorating lamp

When the system generates a **PHOTOMETRY ERROR DURING CUVETTE WASH** event, check to see if a cuvette overflow has occurred. Refer to the topic on recovering from a photometry error during a cuvette wash event in *DxC 700 AU Instructions for Use*.

System Overview

Principles of the ISE Measuring Method

- If a cuvette overflow has occurred, refer to the topic on recovering from a cuvette wheel overflow in the *DxC 700 AU Instructions for Use*. It is necessary to identify and reanalyze all samples affected by the cuvette overflow.
- If a cuvette overflow has not occurred, the system might have generated the PHOTOMETRY ERROR DURING CUVETTE WASH event because of unstable photometry. Refer to the topic on recovering from an unstable photometry error in the *DxC 700 AU Instructions for Use* to determine the cause of the error and perform corrective actions.

Principles of the ISE Measuring Method

The system mixes sample and ISE Buffer Solution using a specified sample ratio in the sample pot of the ISE module (optional). The system aspirates the mixture and passes it to the Na, K, and Cl electrodes. The system measures the potential generated at the electrodes. The system cycles ISE MID Standard Solution between samples to measure the reference potential and to prevent carryover.

Calibration Processing on the ISE

During calibration of the ISE, the system measures both ISE MID Standard Solution and Standard Solution H and L, which have a known concentration. The system obtains the relationship between the electrode potential and ion concentration then, and calculates the Na, K, and Cl calibration setup coefficient S (slope).

Calibration

Figure 1.19 Calculation of Slope

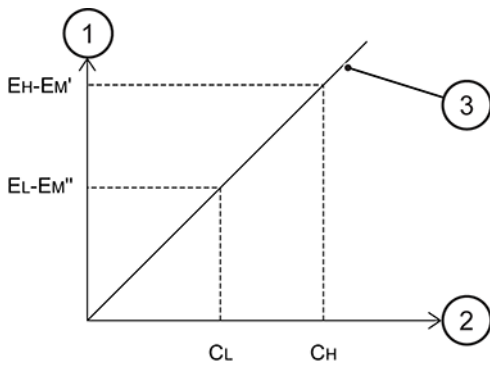

1. Potential difference (mV)
2. CONC (logarithm) mmol/L
3. Calibration

C_H	A known concentration of Standard Solution H used for calibration
C_L	A known concentration of Standard Solution L used for calibration
E_H-E_M'	A potential difference between Standard Solution H and ISE MID Standard Solution
E_L-E_M''	A potential difference between Standard Solution L and ISE MID Standard Solution

The system creates a calibration using a potential difference between the two points of known concentration.

Correction by M-CAL

M-CAL at the ISE is data correction using a calculation formula, $Y = AX + B$.

Y: corrected value, X: measured value.

Coefficients A and B are obtained in the following way.

Correlation regression with a measurement (y) obtained from the system before correction and value (x) obtained from any conventional method or standard method.

You can obtain coefficients A and B by a 3-point regression calibration or Manual calculation.

$$y = ax + b$$

gives

$$x = (1/a)y - (b/a)$$

Therefore, $A = -1/a$, $B = -b/a$

The two methods to perform M-CAL are:

- Manual: Obtain A and B with the previously listed equations and enter them as the factors.
- CRS (3-point regression CAL): Optional.

Correction by A-CAL

Figure 1.20 Correction by A-CAL

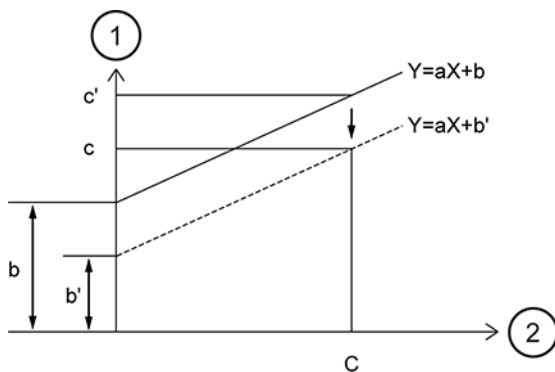

1. Y (measured value)

2. X (known concentration of a sample subject to A-CAL)

- Corrected value: $c' - c$
- $b' = b - (c' - c)$
- a = factor
- b = offset

Let a known concentration of a sample for A-CAL be c , and let the measurement obtained by this system from a sample for A-CAL after an M-CAL correction be c' . To make the

System Overview

Key Sub-Processes

known concentration of the sample for A-CAL and a measurement obtained by this system consistent, correct the difference between c and c' using A-CAL. Here, $Y = aX + b$ is $Y = aX + b'$.

You can apply this A-CAL correction to values that have been subject to an M-CAL correction.

Key Sub-Processes

This section describes some important analysis steps.

Sample Identification

A test order is an instruction to perform specified tests on a sample. When you place a sample onto the system, it uses the test order information to link the sample to the required tests. The system must be able to identify samples correctly. The system can also use sample bar codes to link test order information to each sample to be tested.

The system recognizes samples on racks by three sample identification modes.

Bar Code (Sample ID) Mode

The system reads the sample bar code label on each sample cup and then links this information to a corresponding order to perform analysis. You can place samples in any order, and the system allows empty spaces on the racks. It is critical to test that sample bar codes match sample orders.

Sequential Mode

The system analyzes the first sample on the first rack presented, using the information in the first test order. It uses the second test order for the second sample on the rack, and so on. In sequential mode, the system does not read the sample bar code label, unless you select **Sequential Sample ID Read** in the Analysis Mode screen (**CONFIG. > Analysis Mode**). When you select **Sequential Sample ID Read**, the system reads a sample bar code label, but does not use the sample ID for test orders. For more information, refer to [Analysis Mode Screen](#).

Place samples on the racks in numerical order, without empty spaces on the rack.



Running the system in sequential mode is not recommended because of the possibility of sample and result mismatch. If you must run a sample in sequential mode, be careful and use extra cross checks.

To be sure of correct sample analysis in sequential mode, confirm that there are no empty spaces in the racks.

If a Beckman Coulter Representative has programmed the system during installation to analyze only the same sample type in the same rack, never mix different sample types in one rack.

**Note**

If the DxC 700 AU connects to a Laboratory Automation System, sequential mode is not available.

Rack ID Mode

The system reads the rack ID and assigns the sample No. according to the cup position in the rack. Set the samples in the rack in the order entered for the samples at the time of sample order. The system does not read sample bar code labels in Rack ID mode.

For example, when the samples from No. 1 to No. 10 are set on rack ID 0001 and the samples from No. 11 to No. 20 are set on rack ID 0002, you can find sample No. 14 in position 4 on rack ID 0002 and sample No. 57 in position 7 on rack ID 0006. In Rack ID mode, you can place the racks in any order into the rack input area. The maximum rack ID for Rack ID mode is 999.

**Warning**

In Rack ID mode, use extreme caution when placing samples in the rack to avoid concordance errors (incorrect sample and result). Take time to perform cross checks on racks and samples.

**Note**

If the DxC 700 AU connects to a Laboratory Automation System, Rack ID mode is not available.

Sample Transfer

Sample tubes or cups containing sample are placed on the system using sample racks or placed on the STAT table. Select **Start** to start the analysis from a rack. Select **Start STAT** to start the analysis from the STAT table. The system determines the test order information and the sample probe aspirates the sample.

Program the sample volume and diluent volume for each test in **CONFIG. > Test Volume and Methods > General**.

After dispensing, the sample probe is washed in the wash well with deionized water internally and externally.

Reagent Transfer

The system has two reagent transfer probes. Any required reagent is aspirated from the corresponding reagent bottle in the reagent refrigerator and dispensed into the cuvette in the incubation bath. The system uses information programmed in **CONFIG. > Test Volume**

System Overview

Key Sub-Processes

and Methods > General to determine the quantity of reagent to use. A mixture of sample and reagent which has been dispensed into one cuvette is called a reaction mixture.

The reagent probes are washed internally and externally with deionized water, between each reagent dispense, to ensure minimal reagent carryover. In addition, you can program contamination avoidance parameters. For more information, refer to [Contamination Parameters Screen](#).

Reaction Mixture Mixing

The mix bar component uses fluororesin-coated mix bars to mix the reaction mixture in the cuvette to uniformity. Two mix bar components are provided. Each of the two mix bar components has three sets of mix bars. While one of the three sets mixes, the other two are washed in the wash well with diluted wash solution and rinsed with deionized water.

Reaction Mixture Incubation and Washing

The cuvette wheel is set in an incubation bath to keep the reaction temperature in the cuvette at a constant level.

When the photometer readings complete, the wash nozzle component aspirates the reaction mixture in a cuvette, and the cuvette is washed with diluted wash solution, rinsed with deionized water, and then dried.

Photometric Measurement

Various chemical components in the sample and the reagents produce a color reaction in the cuvette. Light from a halogen lamp passes through the reaction mixture, and separates into specific wavelengths by a diffraction grating. A photodetector measures the optical density of the reaction mixture. The system performs measurements at 18-second intervals throughout the reaction period. The system uses the measured values for the reaction period and wavelengths that are defined in the Test Volume and Methods: General tab (**CONFIG. > Test Volume and Methods > General**) for concentration calculation.

Online Test Orders and Test Orders Using Keyboard Entries

LIS Direction Online

An LIS direction online order is possible when you set **Test Order Information Receive** in the Online: Setup tab (**CONFIG. > Online > Setup**) to **LIS Direction**, and the DxC 700 AU connects to a Laboratory Information System (LIS) over a TCP/IP connection. The LIS sends test order information to the DxC 700 AU, and the DxC 700 AU saves the information without an inquiry from the DxC 700 AU at any time.

If LIS direction online connects an LIS and a DxC 700 AU, the operator does not have to perform test orders from the DxC 700 AU.

Real-time Online

A real-time online test order is possible when you set **Test Order Information Receive** in the Online: Setup tab (**CONFIG. > Online > Setup**) to **Realtime**, and the DxC 700 AU connects to

an LIS. In responding to any inquiry from the analyzer to the LIS, the system processes everything automatically.

If an LIS and the DxC 700 AU connect real-time online, the operator does not have to perform test orders from the DxC 700 AU.

Batch Online

A batch online test order is possible when you set **Test Order Information Receive** in the Online: Setup tab (**CONFIG. > Online > Setup**) to **Batch**, and the DxC 700 AU connects to an LIS over an RS-232C connection. The DxC 700 AU sends batch inquiries to the LIS for sample information (such as test item) for multiple samples.

Keyboard Entry

You can perform manual sample ordering by sample number at the DxC 700 AU.

You can perform manual sample ordering at the DxC 700 AU with or without an LIS.

Sample Identification and Date and Time

Sample Number

This value is a 4-digit number used to identify each sample. Sample number assignment methods vary with sample identification modes.

Sample ID

A sample ID used to identify each sample.

In sample ID (Bar code) mode, the system reads the bar code label attached to each sample cup and uses it as the sample ID.

Rack ID

A rack ID is used for identifying each rack. In Rack ID mode, the sample number of each sample is automatically assigned using the rack ID and the position on the rack. When the DxC 700 AU is connected to a Laboratory Automation System, racks are not used on the system.

System date and time

This value is the system date and time under the management of the internal clock of the system.

Index date and time

An index, created by setting the date and time, is a data file used as the main search key for sample data.

The current date and time is automatically set as the index date and time on starting up the system; however, this option is an operator-defined option.

System Overview

Understanding and Handling Reagents, Calibrators, and Controls

Understanding and Handling Reagents, Calibrators, and Controls

This section describes the reagents used on the DxC 700 AU.

Reagents

Beckman Coulter reagents are highly concentrated, and most reagents are ready to use.

The system can use reagents, calibrators, and control materials supplied by manufacturers other than Beckman Coulter. Confirm usability with the reagent manufacturer or distributor.

Reagents are supplied in bottles of 15 mL, 30 mL, 60 mL, or 120 mL. Set reagent bottles containing reagents in the reagent refrigerator fixed by adapters and partitions, depending on the size.

The system reads the bar code label on a reagent bottle and registers it.

Sample Diluents

For samples with a high concentration, the system uses deionized water or other diluent for automatic dilution analysis. The diluent is in a 60 mL bottle placed in a designated diluent bottle position labeled 61. The following figure shows the Diluent/W2 position close to the reagent (R1) refrigerator.

Figure 1.21 Sample Diluent Bottle Position

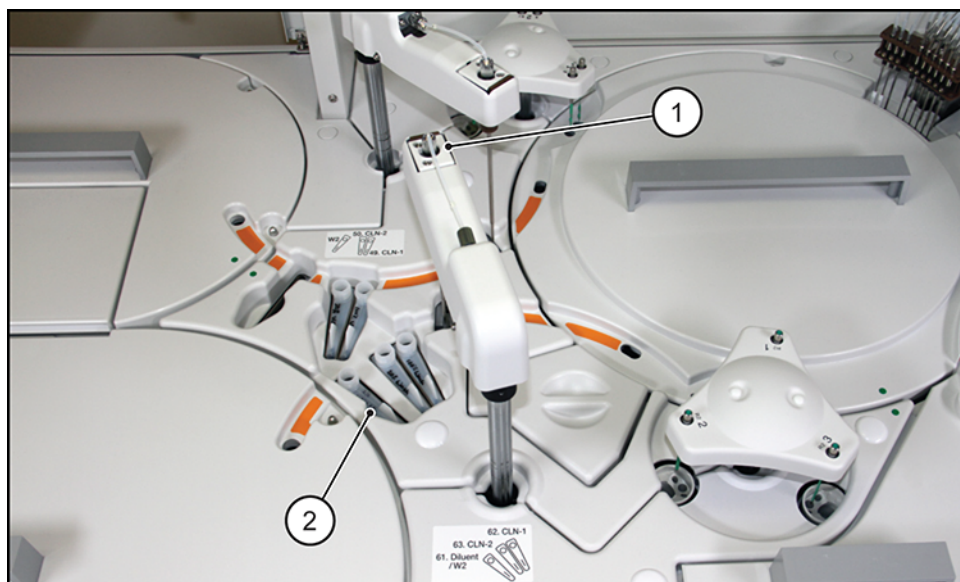

1. Reagent probe

2. Sample diluent bottle

Calibrators

You can program a maximum of 200 different calibrators on the system.

Calibrate in the following situations:

- When a reagent bottle has changed, and you have programmed the system to calibrate new bottles in **Advanced Calibration** in the Calibration setup: General tab (**CONFIG. > Calibration setup > General**).
- When a reagent lot has changed.
- When you have used the same lot on the system for a predefined number of days.
- QC results fell outside the specified control limits.
- There has been major preventive maintenance, or critical part replacement, and QC performance is affected.

For more information on test-specific calibration, refer to the reagent *Instructions for Use*.

For more information on operation precautions, refer to the topic on calibrating tests in the *DxC 700 AU Instructions for Use*.

Quality Control Samples

Perform Quality Control (QC) analysis after calibration and as directed after particular maintenance procedures to confirm that the system is working correctly. Perform QC analysis at regular intervals for verification of system stability. Perform this check using a control sample from the QC supplier.

For more information on operation precautions, refer to the topic on processing quality control (QC) in the *DxC 700 AU Instructions for Use*.

ISE Quality Control Materials

Commercial Control Materials for the ISE

Beckman Coulter advises using the most widely accepted, reliable ISE control materials available locally. Substances in control serum can affect ISE tests.

Commercial control materials contain additives for regulating the density of components, and they contain various preservatives. If you measure this type of control material using an ion selective electrode, the added materials can cause problems with the electrode, and could cause measurement errors, including abnormal data.



The following items affect measurement:

- Samples that contain antibiotics or other drugs can cause errors.
- Bilirubin does not affect the K and Cl electrodes, but small positive errors occur in the Na electrode.
- Positive errors occur in the Cl electrode caused by halogen ions (Br, I).
- A positive error is recognized in the K electrode for samples where the hematocrit value is 65% or more. If a hemolytic sample is used, K shows an excessively positive error.
- Use the anticoagulant Lithium Heparin. Any other anticoagulants can cause an error in measured values. Use the anticoagulant immediately after collecting blood.

System Overview

Understanding and Handling Reagents, Calibrators, and Controls

- **To prevent fluctuations caused by sample evaporation, keep serum and plasma samples tightly closed in a refrigerator. Also, measure samples stored in a refrigerator after the temperature of the sample has returned to room temperature.**

Common Test Parameters Menu

Test Name Parameters Screen

Use the Test Name Parameters screen (**CONFIG. > Test Name Parameters**) to program test parameters, including the test name, reagent ID, and alarm tests.

Test numbers 1 to 120 are pre-programmed as closed or open test numbers.

- Closed Test Numbers - During installation, Beckman Coulter Representative loads a CD containing Beckman Coulter test parameters, which occupy a set of closed test numbers. Closed test numbers reduce manual programming time and possible programming errors.
- Open Test Numbers - The system supports the ability to add tests that are not from Beckman Coulter. Tests that use reagents that are not from Beckman Coulter use open test numbers.

The system allows a maximum of 120 programmed tests. You can print the contents of the Test Name Parameters screen.

Table 2.1 Test Number Programming Options and Descriptions

Test Number	Programming Options	Description
1 to 90	Closed or Open	Customer specific
91 to 95	None	FSE Troubleshooting
96 to 99	None	LIH, Na, K, Cl
100 to 102	None	HbA1c
103 to 120	Closed or Open	Customer specific

For closed test numbers, you cannot program some fields in the Test Volume and Methods: General tab (**CONFIG. > Test Volume and Methods > General**). For detailed information, refer to [Test Volume and Methods: General Tab](#).

You can program all other fields on the Configuration Parameters menu, including the fields that are in the tabs on the Test Name Parameters screen (Test Name, Long Name, Reagent ID, Alarm Tests, and Multi Reagent Switch), for closed or open test numbers.

Test Name Tab

Select **CONFIG. > Test Name Parameters > Test Name**.

Parameters

Common Test Parameters Menu

Figure 2.1 Test Name Parameters: Test Name Tab

<< Configuration Parameters > Common Test Parameters > Test Name Parameters

Test Name Parameters
Panel
Group of Tests

Test Name
Common Reagents

LIH Reagent
Dedicated

No.	Test Name	Long Name	Reagent ID	Alarm Tests	Multi Reagent Switch	Reagent Detail
1	ALB	Albumin	002	10	No	
2	ALP	Alkaline Phosphatase	004	10	No	
3	ALT	Alanine Transferase	007	10	No	
4	AMY	Amylase	008	10	No	
5	AST	Aspartate Transferase	009	10	No	
6	CO2	Bicarbonate	037	10	No	
7	DBILC	Direct Bilirubin	011	10	No	Color(Blank:8.DBB)
8	DBB	DirectBilirubinBlank	010	10	No	Blank(Color:7.DBILC)
9	TBILC	Total Bilirubin	012	10	No	Color(Blank:10.TBB)
10	TBB	TotalBilirubinBlank	025	10	No	Blank(Color:9.TBILC)
11	CA	Calcium Arsenazo	117	10	No	
12	NDBILJ	Direct Bili - 181	181	10	No	
13	CHOL	Cholesterol	016	10	No	
14	AMMON	Ammonia	154	10	No	
15				10	No	
16	CK	CreatPhosphoKinase	079	10	No	
17	CRE	Creatinine	078	10	No	
18	GGT	Gamma Glutamyl Trans	019	10	No	
19	GLU	Glucose	021	10	No	
20				10	No	

Edit
F1
Sample Blank
F5
Calculated Tests
F6
Delete
Test Parameters
Print
F8

Program the following items as required.

Table 2.2 Test Name Tab Description

Item	Contents	Input Notes
LIH Reagent	Dedicated or Non Dedicated	If you select Dedicated the system uses test number 96. LIH with LIH Reagent (OSR62166) as the reagent. LIH Reagent has a reagent ID and you can place it in any open position in the R1 refrigerator. If you select Non Dedicated the system uses an existing (on-board) test and reagent for LIH testing. You can program a maximum of three tests to the Group for LIH analysis.
No.	1 to 120	You can program a maximum of 120 tests. Closed test numbers are pre-programmed; you manually program open test numbers. The system processes tests on a sample in the order (1 to 120) that is displayed. The system reserves test numbers 91 to 95 for FSE Troubleshooting, 96 for LIH, 97 for Na, 98 for K, 99 for Cl, 100 for HbA1c, 101 for T-Hb, 102 for A1c, and you cannot change them.
Test Name	An abbreviated test name.	A maximum of 6 characters. The system pre-programs test names for test numbers 96 to 102 and you cannot change them.
Long Name	A complete test name.	A maximum of 20 characters.

Table 2.2 Test Name Tab Description (Continued)

Item	Contents	Input Notes
Reagent ID (for all countries and regions except Japan)	3 digits (000 to 999)	The 3-digit Reagent ID located on the top, right side of the reagent IFU, or the first 3 digits from the reagent ID label. For two tests to use the same bottle of reagent, enter the same reagent ID. Available for reagent ID or fixed reagents. In Reagent Management , both test names display for the bottle.
Manufacturer ID (for Japan only)	3 digits (000 to 999)	The first three digits of the reagent ID. The reagent manufacturer defines the Manufacturer ID. Refer to the reagent <i>Instructions for Use</i> .
Test Code (for Japan Only)	2 digits (00 to 99)	The 2 digits of the reagent ID following the first 3 digits. Refer to the reagent <i>Instructions for Use</i> .
Alarm Tests	1 to 200 The default is 32.	The quantity of tests remaining when the system generates a Reagent Insufficient event.
Multi Reagent Switch	Yes or No	Yes: When the system is using multiple sets of an R1/R2, and the R1 or R2 becomes empty in the first set, the analyzer switches to the second set of R1/R2 at the same time. One indicator bar displays for R1 and R2 in Reagent Management . No: The default setting. If an R1 or R2 becomes empty, the analyzer does not switch to the second set of R1/R2 at the same time. An indicator bar displays for R1 and R2 in Reagent Management .  Caution Beckman Coulter recommends selecting Yes for Multi Reagent Switch for all Beckman Coulter reagents.
Reagent Detail	Displays a comment indicating the test is a sample blank test or a calculated test.	Display only and not enterable.



Changing the test name affects all results associated with that test number. The system assigns the new test name to any previously reported results (with the old test name). Use extreme caution when you change the test name.

Parameters

Common Test Parameters Menu

Do not change the test name without noting the time and date of the change and then confirming any results printed before this time and date.

Important

The system processes tests on a sample in the order (1 to 120) that is displayed, with some exceptions. For information on contamination prevention, refer to [Contamination Parameters Screen](#).

Sample Blank [F5]

Interference from other substances in the serum might affect the measured optical density. To correct this interference, the system performs a sample blank correction. Sample blank correction uses the terms color and blank, which refer to the active reagent (color) and the inert reagent (blank). The system multiplies the OD value of Y obtained from the formula $Y = X - B$ (X is the OD value of a color item and B is the OD value of a blank item) with a factor. You can program a maximum of 10 sample blank tests.

Sample Blank tests include total and direct bilirubin. These tests contain an R1 color reagent and an R1 blank reagent.

- Select **CONFIG. > Test Name Parameters > Test Name > Sample Blank [F5]**. The Sample Blank dialog displays.

Figure 2.2 Sample Blank Dialog

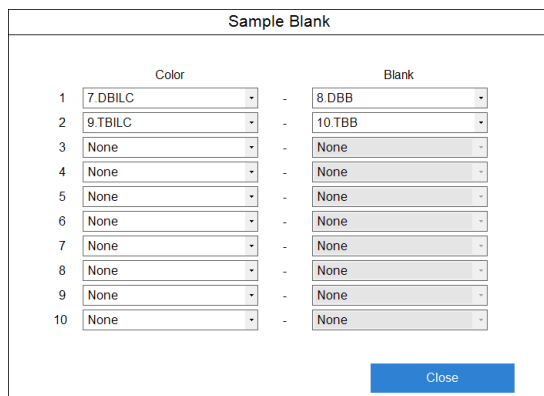

	Color		Blank
1	7.DBILC	-	8.DBB
2	9.TBILC	-	10.TBB
3	None	-	None
4	None	-	None
5	None	-	None
6	None	-	None
7	None	-	None
8	None	-	None
9	None	-	None
10	None	-	None

- In **Color**, select the test to assign a color item.
- In **Blank**, select the test to assign a blank item.
- Select **Close** to save the programming.

Note

You cannot program calculated tests as color Items or blank Items.

Calculated Tests [F6]

You can program a maximum of 20 tests as a calculated test. Refer to [Calculated Tests Tab](#) to program the specific tests and formula for the calculation.

 **Note**

Program a calculated test name in the Test Name tab before you select it in the Calculated Tests dialog.

- Select **CONFIG. > Test Name Parameters > Test Name > Calculated Tests** [F6]. The Calculated Tests dialog opens.

Figure 2.3 Calculated Tests Dialog

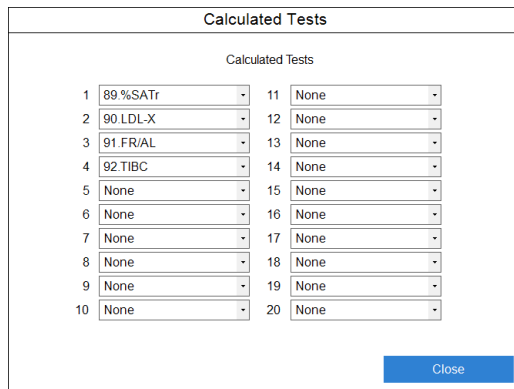

- Select the calculated test name.
- Select **Close** to save the programming.

Common Reagents Tab

You can program common reagents for the R1-2 of a 3-part reagent that you use for more than one test. Assign the common reagent to the test in the General tab (**CONFIG. > Test Volume and Methods > General**). You can program a maximum of 10 common reagents.

Select **CONFIG. > Test Name Parameters > Common Reagents**.

Parameters

Common Test Parameters Menu

Figure 2.4 Test Name Parameters: Common Reagents Tab

<< Configuration Parameters > Common Test Parameters > Test Name Parameters

Test Name Parameters
Panel
Group of Tests

Test Name

Common Reagents

<Editing>

No.	Common Reagent Name	Reagent ID	Alarm Tests	Onboard Stability Period	
				Day	Hour
1			32		
2			32		
3			32		
4			32		
5			32		
6			32		
7			32		
8			32		
9			32		
10			32		

Save
F1

Table 2.3 Common Reagents Tab Description

Item	Contents	Input Notes
Common Reagent Name	Reagent name	A maximum of 6 characters.
Reagent ID (for all countries and regions except Japan)	3 digits (000 to 999)	The 3-digit Reagent ID located on the top, right side of the reagent IFU, or the first 3 digits from the reagent ID label.
Manufacturer ID (for Japan only)	3 digits (000 to 999)	The first three digits of the reagent ID. The reagent manufacturer defines the Manufacturer ID. Refer to the reagent <i>Instructions for Use</i> .
Test Code (for Japan Only)	2 digits (00 to 99)	The 2 digits of the reagent ID following the first 3 digits. Refer to the reagent <i>Instructions for Use</i> .
Alarm Tests	1 to 200. The default is 32.	Quantity of tests remaining before the system generates a Reagent Insufficient event.
Onboard Stability Period	Day (0 to 999) Hour (0 to 23)	Hours or days until the reagent onboard stability expires.

Panel Screen

A panel is a group of tests that you typically order at the same time. Using a panel reduces the quantity of selections needed, because a single panel is selected instead of multiple tests. You can program a maximum of 100 panels (Number 0 to Number 99) for samples, reagent blank, calibration, and QC. You can program a maximum of 99 tests in a panel. The

quantity of sample blank tests, LIH, and sample type limits the quantity of tests that you can program in a panel.

Assign each panel a name.

You cannot select unavailable tests.

You can only select ISE tests when the sample type is Serum or Urine.

For more information, contact Beckman Coulter.

Panel: Patient Sample Tab

Select **CONFIG. > Panel > Patient Sample**.

Figure 2.5 Panel: Patient Sample Tab

<< Configuration Parameters > Common Test Parameters > Panel

Table 2.4 Patient Sample Tab Description

Item	Contents	Input Notes
Type	Serum, Urine, Other-1, Other-2, or Whole Blood	
Panel Name (option)	0 to 99	
Panel Name (selected option)	Panel name	A maximum of 20 characters.
Selected Tests	Displays the quantity of tests selected (highlighted in blue) in the panel.	

Note

You cannot select tests that are not available.

Parameters

Common Test Parameters Menu

You can select ISE tests only when the sample type is Serum or Urine.

The system displays 100. HbA1c, 101.T-Hb and 102. A1c, but the fields are unavailable, and you cannot select them.

Panel: RB/ACAL Tab

Select **CONFIG.** > **Panel** > **RB/ACAL**.

Figure 2.6 Panel: RB/ACAL Tab

<< Configuration Parameters > Common Test Parameters > Panel

Panel Name	Type	Selected Tests
0	Serum	51

Test Code	Test Name	Test Code	Test Name	Test Code	Test Name	Test Code	Test Name
1	ALB	2	ALP	3	ALT	4	AMY
5	AST	6	CO2	7	DBILC	8	DBB
9	TBILC	10	TBB	11	CA	12	NDBILI
13	CHOL	14	AMMON	15		16	CK
17	CRE	18	GGT	19	GLU	20	
21	IRON	22		23	LDH	24	
25	LIPASE	26	LI	27	MG	28	PHOS
29	TP	30	eCHOL	31	eBUN	32	BUN
33	TRIG	34		35		36	
37	UA	38	UCSFP	39		40	
41	HDL-G	42	UICr	43	FRUC	44	LDL-G
45	BHB	46		47		48	
49		50	FERR	51		52	
53		54		55		56	
57		58		59	MALB	60	PALB
61	RF	62	TRF	63		64	
65		66	ACETA	67		68	AMIK
69	CARB	70	DIG	71	GENT	72	
73		74		75		76	
77	PBARB	78	PHENY	79		80	
81		82	SAL	83	THEO	84	TOP
85	VPA	86	VANC	87		88	
89	%SATr	90	LDL-X	91	FR/AL	92	TIBC
93	TIBCr	94		95		96	LIH
97	Na	98	K	99	Cl	100	HbA1c%
101	T-Hb	102	HbA1c	103		104	
105		106		107		108	
109		110		111		112	
113		114		115		116	
117		118		119		120	

ACAL+RB (yellow) One Point (pink) RB Only (blue)

Edit [F1] Print [F8]

Table 2.5 RB/ACAL Tab Description

Item	Contents	Input Notes
Panel Name (option)	0 to 99	
Panel Name (selected option)	Panel name	A maximum of 20 characters.
Type	Serum, Urine, Other-1 or Other-2	
Selected Tests	Displays the quantity of tests selected (highlighted in yellow, pink, or blue) in the panel.	<p>Select Edit [F1], and then select Calibration Options [F5] to change between the available calibration options:</p> <p>ACAL + RB (yellow)</p> <p>One Point (pink)</p> <p>RB Only (blue)</p> <p>Refer to Summary of Calibration Types and Calibration Setup: General Tab for more information.</p>

 **Note**

The programming in the General tab (**Calibration Setup > General**) determines the calibration options available from **Calibration Options** [F5].

You cannot select tests that are not available.

You can select ISE tests only when the sample type is Serum or Urine.

Panel: QC Tab

Select **CONFIG. > Panel > QC**.

Figure 2.7 Panel: QC Tab

<< Configuration Parameters > Common Test Parameters > Panel

Table 2.6 QC Tab Description

Item	Contents	Input Notes
Panel Name (option)	0 to 99	Panel numbers 87 to 99 are default QC panels and correspond to a specific group and sample type. Refer to the following note.
Panel Name (selected option)	Panel name	A maximum of 20 characters.
Type	Serum, Urine, Other-1 or Other-2	
Selected Tests	Displays the quantity of tests selected (highlighted in blue) in the panel.	

Parameters

Common Test Parameters Menu



Note

QC panels 87 to 99 are the default QC panels that the system automatically orders in the Rack (QC) screen (**TEST > Rack (QC)**). The QC panel numbers 87 to 99 correspond to a specific group and sample type:

- Number 87: Serum: For Group 1
- Number 88: Serum: For Group 2
- Number 89: Serum: For Group 3
- Number 90: Urine: For Group 1
- Number 91: Urine: For Group 2
- Number 92: Urine: For Group 3
- Number 93: Other-1: For Group 1
- Number 94: Other-1: For Group 2
- Number 95: Other-1: For Group 3
- Number 96: Other-2: For Group 1
- Number 97: Other-2: For Group 2
- Number 98: Other-2: For Group 3
- Number 99: Whole Blood: For Groups 1, 2, and 3



Note

You cannot select tests that are not available.

Group of Tests Screen

A Group is a collection of tests that you can program as the tests on board the analyzer. You can program three Groups of tests. Specify the Group in the Create Index dialog (**HOME > Create Index [F1]**). The system confirms that the reagents required for the Group are in the reagent refrigerators during the reagent check.

Program a maximum of 60 photometric tests plus the 3 ISE tests (63 total) in each Group.

Tests print in the order that you assign them to the Group. To change the test print order, select **CONFIG. > Group of Tests > Edit [F1]**. Select the test to move, then select **Forward [F2]** or **Backward [F3]**. LIH and calculated tests print last.

Select **CONFIG. > Group of Tests**.

Figure 2.8 Group of Tests Screen

<< Configuration Parameters > Common Test Parameters > Group of Tests

Table 2.7 Group of Tests Screen Description

Item	Contents	Input Notes
Group (option)	1, 2, or 3	
Group (selected option)	The Group name	A maximum of 20 characters.
LIH Selection	Select All or Selectable	<p>Select All: Order LIH automatically on every sample. If you do not add test 96. LIH to any Group (1, 2, or 3) that has tests programmed, a red Incorrect Parameter message displays, and analysis cannot start.</p> <p>Selectable: Order LIH as needed on samples.</p>
LIH Test Setting [F6]	A maximum of 3 tests for LIH analysis.	<p>This option is only available if you set LIH Reagent to Non Dedicated in the Test Name Parameters: Test Name tab (CONFIG. > Test Name Parameters > Test Name).</p> <p>The system uses an existing (on board) test and reagent for LIH testing.</p> <p>You can select a maximum of 3 tests from the Group for LIH analysis.</p>

Parameters

Specific Test Parameters Menu

Table 2.7 Group of Tests Screen Description (Continued)

Item	Contents	Input Notes
Test Setting [F5]	Select (highlight in blue) the tests to include in the Group.	Select tests in the order to display and print. The <Output Order> section displays the print order of the tests. You cannot select calculated tests to include in the Group because the system performs calculated tests automatically when you order all tests on a sample that are part of the calculated test.
Forward [F2] and Backward [F3]	Change the display and print order (output order) of the tests.	Select Edit [F1], then select the test to move, then select Forward [F2] and Backward [F3]. LIH and calculated tests print last.

Figure 2.9 Test Setting Dialog

Test Setting

Group Selected Tests

1 ALB	2 ALP	3 ALT	4 AMY	5 AST	6 CO2	7 DBILC	8 DBB
9 TBILC	10 TBB	11 CA	12	13	14	15	16
17.	18.	19.	20.	21.	22.	23.	24.
25.	26.	27.	28.	29.	30.	31.	32.
33.	34.	35.	36.	37.	38.	39.	40.
41.	42.	43.	44.	45.	46.	47.	48.
49.	50.	51.	52.	53.	54.	55.	56.
57.	58.	59.	60.	61.	62.	63.	64.
65.	66.	67.	68.	69.	70.	71.	72.
73.	74.	75.	76.	77.	78.	79.	80.
81.	82.	83.	84.	85.	86.	87.	88.
89.	90.	91.	92.	93.	94.	95.	96 LIH
97 Na	98 K	99 Cl	100 HbA1c	101 T-Hb	102 A1c	103	104.
105.	106.	107.	108.	109.	110.	111.	112.
113.	114.	115.	116.	117.	118.	119.	120.

Specific Test Parameters Menu

Program parameters in the Test Volume and Methods (**CONFIG. > Test Volume and Methods**), Rerun Test Parameters (**CONFIG. > Rerun Test Parameters**), and Rerun Check Parameters (**CONFIG. > Rerun Check Parameters**) screens.

Test Volume and Methods Screen

Program specific test parameters, LIH parameters, ISE parameters, HbA1c parameters, calculated tests, and reference intervals for tests.

 **Caution**

Incorrect test parameters cause errors in analysis results, and can cause an incorrect diagnosis. Visually confirm test volume and methods settings against published settings, and analyze with materials with known concentrations.

For more information on displaying a list of programmed values, refer to [Table 2.19 Test Volume and Methods: General Tab Description](#).

Test Volume and Methods: General Tab

Program the specific analysis parameters for each test. Program the test name before programming specific tests parameters. For more information, refer to [Test Name Tab](#).

Pre-programming of test numbers 1 to 90 and 103 to 120 as either closed or open depends on the specific requirements for your laboratory.

The programmable parameters in the Test Volume and Methods screen (**CONFIG. > Test Volume and Methods**) determine whether to program a closed or open test number.

- Closed test numbers have fixed parameters (not programmable) and programmable parameters. After selecting **Edit** [F1], the background color becomes gray for fixed parameters and white for programmable parameters.
 - Fixed parameters (not editable)
 - Sample Volume and Dilution
 - Pre-Dilution Rate and Diluent Bottle
 - Reagent Volume R1 (R1-1) and Dilution
 - Reagent Volume R1-2 and Dilution
 - Reagent Volume R2 (R2-1) and Dilution
 - Common Reagent Type and Name
 - Wavelength (Primary and Secondary)
 - Method
 - Reaction Slope
 - Measuring Point-1 (First and Last)
 - Measuring Point-2 (First and Last)
 - Analytical Measuring Range (High)
 - Onboard Stability Period
 - Editable parameters
 - Reagent OD Limit First (Low and High)
 - Reagent OD Limit Last (Low and High)
 - Analytical Measuring Range (Low)
 - Correlation Factor (A and B)
 - LIH Influence Check
- For open test numbers, you can program all parameters.
- You can program all other parameters in the Configuration Parameters menus, including in the Test Name Parameters screen (Test Name, Long Name, Reagent ID, Alarm Tests, and Multi Reagent Switch), for closed or open test numbers.

Parameters

Specific Test Parameters Menu



Caution

When Saving or Loading Parameters:

Follow all cautions in the *DxC 700 AU Instructions for Use* when using external media to save or load parameters. To save parameters for each DxC 700 AU, you need one CD-R or USB external memory device.

You save pre-programming of test numbers 1 to 90 and 103 to 120 as either closed or open along with other parameters on the external media. If you load the parameters from one DxC 700 AU onto another DxC 700 AU with a different configuration of closed and open test numbers, the following message displays after 30 days when you turn on the DxC 700 AU. If the following System Start message displays, contact Beckman Coulter.

Figure 2.10 System Start Dialog

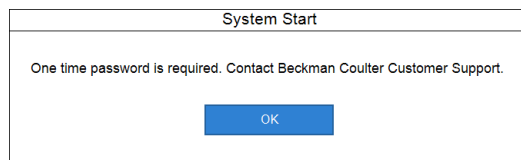

Select **CONFIG. > Test Volume and Methods > General.**

Figure 2.11 Test Volume and Methods: General Tab

Test Volume and Methods		Rerun Test Parameters		Rerun Check Parameters	
General		LIH		ISE	
HbA1c		Calculated Tests		Range	
Test Name	1.ALB	Test No.	Type	Serum	Operation
Sample Volume	1.6 uL	Dilution	0 uL	OD Limit	
Pre-Dilution Rate	1			Min.OD	Max.OD
Reagent Volume	R1(R1-1) 15 uL	Dilution	0 uL	Reagent OD Limit	
	R1-2	Dilution		1st.	Low -2.0000 High 3.0000
	R2(R2-1) 0 uL	Dilution	0 uL	Last	Low -2.0000 High 3.0000
Common Reagent	Type None	Name	None	Analytical Measuring Range	Low -9999999 High 9999999
Wavelength	Pri. 340 nm	Sec.	None nm	Correlation Factor	A 1 B 0
Method	END			Manufacturer Factor	A 1 B 0
Reaction Slope	+ -			Onboard Stability Period	Day Hour
Measuring Point-1	1st. 0	Last	27	LIH Influence Check	No
Measuring Point-2	1st.	Last		Lipemia	+ -
Linearity Limit	%			Icterus	+ -
Lag Time Check				Hemolysis	+ -
Edit F1				List Display F7	Print F8

Enter test parameters from the reagent setting sheet. You cannot program a field that is not available.

Table 2.8 Test Volume and Methods: General Tab Description

Item	Contents	Input Notes
Test Name	Abbreviated test name in a list.	Select the Test Name to program the parameters.
Type	Serum, Urine, Other-1, or Other-2	The sample type.
Operation	Yes or No	<p>Yes: the test is operational for the type displayed.</p> <p>No: the test is not operational for the type displayed. If you program a test as No, it is not available to order or run. The test displays grayed out and is inaccessible in the list of tests.</p>
Sample Volume and Dilution	<p>If Dilution is 0 μL, then you can set the sample volume between 1.0 μL and 25.0 μL.</p> <p>If Dilution is 10 μL, then you can set the sample volume between 1.0 μL and 20.0 μL.</p> <p>The minimum sample volume is 1.0 μL.</p>	<p>You can set Sample Volume in increments of 0.1 μL.</p> <p>The system uses deionized water (0 or 10 μL) dispensed for a sample dilution following the sample dispense.</p> <p>If you set Dilution to 0 μL, then the system aliquots an extra 2.9μL of sample for dispensing accuracy.</p>
Pre-Dilution Rate	1, 3, 5, 10, 15, 20, 25, 50, 75, or 100	Defines the automatic pre-dilution rate. The system uses two cuvettes for dilution and reaction for a test. First the analyzer performs sample dilution with deionized water or other diluent in a dilution cuvette, then dispenses the test sample volume from the dilution cuvette into a reaction cuvette. Refer to Pre-Dilution Rate Volumes for the sample volumes required for each pre-dilution rate.
Reagent Volume	<p>R1(R1-1): 10 to 250 μL</p> <p>R1-2: 0, 5, 10 to 20 μL</p> <p>R2(R2-1): 0, 10 to 250 μL</p>	<p>You can set reagent volumes in increments of 1.0 μL.</p> <p>The total maximum reagent volume and dilution is 250 μL.</p>
Dilution	<p>(R1-1): 0, 10 to 240 μL</p> <p>R1-2: 0, 10 to 20 μL</p> <p>R2(R2-1): 0, 10 to 240 μL</p>	
Wave Length Pri.	340, 380, 410, 450, 480, 520, 540, 570, 600, 660, 700, 750, and 800 nm	

Parameters

Specific Test Parameters Menu

Table 2.8 Test Volume and Methods: General Tab Description (Continued)

Item	Contents	Input Notes
Wave Length Sec.	None, 340, 380, 410, 450, 480, 520, 540, 570, 600, 660, 700, 750, and 800 nm	
Method	END, RATE, FIXED, END1, RATE1, FIXED1	The 1 at the end of a method name indicates a method not using a reagent blank correction. The system does not subtract the reagent blank from the measuring points.
Reaction Slope	+, -	Select + for an increasing reaction curve. Select - for a decreasing reaction curve.
Measuring Point-1 Measuring Point-2	END method, FIXED method <ul style="list-style-type: none"> • First: 0 to 26 • Last: 1 to 27 RATE method <ul style="list-style-type: none"> • First: 0 to 25 • Last: 1 to 27 	Self blank: The system subtracts absorbance of Measuring Point-2 data (caused by sample) from Measuring Point-1 data (reaction data).
Linearity Limit	0 to 100	A check for Rate Methods to confirm if the reaction is non-linear caused by exceeding the defined % variance or OD limits between photometer read points. If the limits are exceeded, the system generates a * flag. Refer to Linearity Limit .
Lag Time Check	YES or NO	You can set Yes for only Rate Methods. <i>Lag time</i> is the time after the system adds all reagents to the sample and before it takes any read points to determine the reaction rate. Refer to Lag Time Check .
OD Limit	-2.0000 to 3.0000	You can program this field for only Rate and Fixed methods. Generates a B flag for less than the minimum OD and a D flag for greater than the maximum OD.
Reagent OD Limit	-2.0000 to 3.0000	Reagent blank OD limits at the first and last read points. Generates a u flag or U flag for less than the minimum reagent OD. Generates a y flag or Y flag for greater than the maximum reagent OD.

Table 2.8 Test Volume and Methods: General Tab Description (Continued)

Item	Contents	Input Notes
Analytical Measuring Range	Low: -9999999 to 9999999 High: Low value to 9999999	The range the analyzer can measure for a reagent. Enter a 7-digit numerical value, not including a minus sign or decimal point. Generates an F flag (over) or G flag (under) flag. If the system cannot calculate a concentration value, it uses the OD value to determine measurements outside of the analytical measuring range. Generates a Fx flag for an OD value greater than the OD of the upper limit of the analytical measuring range. Generates a Gx flag for an OD value less than the OD of the lower limit of the analytical measuring range. Set the number of decimal places in the Range tab.
Correlation Factor	A: -9999999 to 9999999 B: -9999999 to 9999999	Corrects the concentration value with the equation $Y = AX + B$. The system performs the correlation correction after checking the analytical measuring range.
Manufacturer Factor	Display only	This coefficient corrects the concentration value with the equation of $Y=AX+B$. The system corrects the value before checking the analytical measuring range.
Onboard Stability Period	Days (0 to 999) and hours (0 to 23)	The onboard stability period starts when the system performs the reagent check, even if the system does not use the reagent.
LIH Influence Check	Yes or No	Only displays if Beckman Coulter enables the optional Test Specific LIH in System Maintenance. Yes: Flags the result with l, i, or h if the level of LIH exceeds the specific limits of the test. If the system does not perform LIH testing on the sample, the system generates an n flag. No: Does not perform test specific LIH evaluation for the test.
Lipemia	+, ++, +++, +++++, ++++++	If you program Yes in LIH Influence Check , program test-specific LIH criteria from the test-specific reagent setting sheet.
Icterus		
Hemolysis		
Change Reagent Type [F5]	Function button	Select R1-2 to program a 3-part reagent.
Set Common Reagent [F6]	Function button	Program the R1-2 of a 3-part reagent to use for two tests.

Parameters

Specific Test Parameters Menu

Table 2.8 Test Volume and Methods: General Tab Description (Continued)

Item	Contents	Input Notes
List Display [F7]	Function button	Displays a list of all test parameters. Use the list to confirm parameters. Six tests display at a time. Select the sample type to display in Type .

Pre-Dilution Rate Volumes

Table 2.9 Pre-Dilution Rate Volumes

Pre-Dilution Rate	Sample Volume (µL)	Dilution Volume (µL)	Volume in Cuvette
3	50	100	150
5	30	120	150
10	20	180	200
15	15	210	225
20	10	190	200
25	8	192	200
50	4	196	200
75	3	222	225
100	2	198	200

Linearity Limit

Linearity Calculation Method:

$$\frac{|a-b|}{(|c| * 0.5)} * 100 = \text{Linearity limit value (parameter)}$$

a: OD value change quantity of the first half of the reaction curve

b: OD value change quantity of the last half of the reaction curve

c: OD value change quantity of the reaction curve (between photometry start point and end point)

| |: Absolute value

- For a straight line (like the solid line shown in [Figure 2.12 Linearity Calculation Method](#)), the values of a and b become almost the same and linearity becomes 0%.
- For a curved line (like the dotted line shown in [Figure 2.12 Linearity Calculation Method](#)), a becomes smaller and b becomes larger, and linearity becomes 67% approximately.

Figure 2.12 Linearity Calculation Method

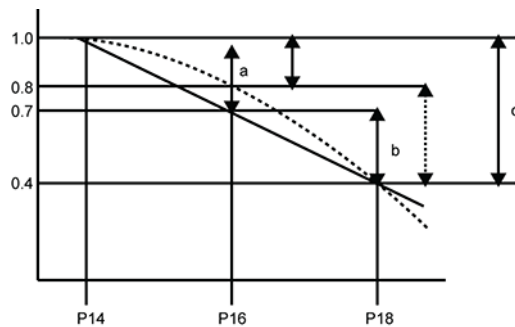

Lag Time Check

If you select **Yes** in **Lag Time Check**, the system performs the following check:

- The Predicted maximum reaction OD (delta OD) is calculated to the concentration.
- Checks the converted concentration against the analytical measuring range.

If more than two points of the measurements fall within the analytical measuring range, the lag time check occurs using the measurement results. The system generates an E flag when the measurement results fail the lag time check.

If only two points or less of the measurements fall within the analytical measuring range, the system calculates the OD using the measurement results obtained before the measuring points programmed in the General tab, for example P11.

LIH Tab

If you assign LIH to Test 96, LIH using Dedicated LIH Reagent or saline, program the LIH parameters. Refer to [Test Name Tab](#).

Select **CONFIG. > Test Volume and Methods > LIH.**

Parameters

Specific Test Parameters Menu

Figure 2.13 Test Volume and Methods: LIH Tab

Test Volume and Methods		Rerun Test Parameters		Rerun Check Parameters	
General	LIH	ISE	HbA1c	Calculated Tests	Range
Test Name	96 LIH	LIH Reagent	Dedicated		
Sample Volume	2.0 uL	Dilution	0 - uL		
Reagent Volume R1(R1-1)	25 uL	Dilution	125 uL		
Onboard Stability Period	Day		Hour		
LIH Judgement Level					
	Lipemia	Icterus	Hemolysis		
+	0.0000	0.0000	0.0000		
++	0.0000	0.0000	0.0000		
+++	0.0000	0.0000	0.0000		
++++	0.0000	0.0000	0.0000		
+++++	0.0000	0.0000	0.0000		
Edit F1				Print F8	

 **Note**

LIH Judgement Level

The system observes OD limits to flag samples for lipemia, icterus, and hemolysis. Each sample prints with LIP (lipemia), ICT (icterus), and HEM (hemolysis) tests with normal, +, ++, +++, +++++, ++++++.

 **Note**

LIH Reagent (OSR62166) is the only validated reagent for sample and test-specific LIH testing.

Table 2.10 LIH Tab Description

Item	Contents	Input Notes
LIH Reagent	Dedicated or Non Dedicated	Displays what you select in the Test Name tab (CONFIG. > Test Name Parameters > Test Name). You can enter values in Sample Volume, Dilution, Reagent Volume, and Onboard Stability Period only if you set LIH Reagent to Dedicated . If you set LIH Reagent to Non Dedicated , the system uses the parameters from the on-board test.

Table 2.10 LIH Tab Description (Continued)

Item	Contents	Input Notes
Sample Volume and Dilution	Sample volume and dilution volume in μL	Set in increments of 0.1 μL . <ul style="list-style-type: none"> • If Dilution is 0 μL, you can set the sample volume from 1.0 to 25.0 μL. • If Dilution is 10 μL, you can set the sample volume from 1.0 to 20.0 μL. • The minimum sample volume is 1.0 μL.
Reagent R1 (R1-1) Volume and Dilution	Reagent volume and dilution volume in μL	Set in increments of 0.1 μL . The total reagent volume and dilution is a maximum of 250 μL . <ul style="list-style-type: none"> • If Dilution is 0 μL, you can set the reagent volume from 10 to 250 μL. • If Dilution is 10 μL, you can set the reagent volume to 0, or from 10 to 240 μL.
Onboard Stability Period	Days (0 to 999) and Hours (0 to 23)	
LIH Judgement Level	Program the judgment level separately for Lipemia, Icterus, and Hemolysis.	Refer to the LIH reagent setting sheet or enter values established by the facility. LIH Reagent with LIH parameters from the reagent setting sheet is the only validated option for test-specific LIH.
	+ : 0.0 to 3.0	
	++ : + value to 3.0	
	+++ : ++ value to 3.0	
	++++ : +++ value to 3.0	
	+++++ : ++++ value to 3.0	

Test Volume and Methods: ISE Tab

If you use the ISE option, program the operation, analytical measuring range, and correlation factor for the serum and urine sample types.

Select **CONFIG. > Test Volume and Methods > ISE.**

Parameters

Specific Test Parameters Menu

Figure 2.14 Test Volume and Methods: ISE Tab

Test Volume and Methods		Rerun Test Parameters			Rerun Check Parameters		
General	LIH	ISE	HbA1c	Calculated Tests	Range		
		Type: Serum				Type: Urine	
Operation	97 Na No -	98 K No -	99 Cl No -	97 Na No -	98 K No -	99 Cl No -	
Sample Volume	20.0 uL	---	---	20.0 uL	---	---	
Dilution	10.0 uL	---	---	10.0 uL	---	---	
MID CONC	140.0	4.0	100.0	140.0	4.0	100.0	
STD CONC Low	130.0	3.5	85.0	50.0	10.0	50.0	
STD CONC High	160.0	6.0	120.0	200.0	100.0	180.0	
LIH Influence Check	No -	No -	No -	-	-	-	
Lipemia	+ -	+ -	+ -	-	-	-	
Icterus	+ -	+ -	+ -	-	-	-	
Hemolysis	+ -	+ -	+ -	-	-	-	
Cell 1 Analytical Measuring Range	Low -9999999 High 9999999	-9999999 9999999	-9999999 9999999	-9999999 9999999	-9999999 9999999	-9999999 9999999	
Correlation Factor	A 1 B 0	1 0	1 0	1 0	1 0	1 0	

Edit F1
Print F8



Note

Sample Volume, Dilution, MID CONC, STD CONC Low, and STD CONC High display the pre-programmed values and you cannot change them.

Program the Operation, LIH Influence Check, Analytical Measuring Range, and Correlation Factor for Serum and Urine.

Table 2.11 Test Volume and Methods: ISE Tab Description

Item	Contents	Input Notes
Operation	Yes or No	Select Yes to enable operation for Na, K, and Cl testing for Serum or Urine.
LIH Influence Check	Yes or No	LIH Influence Check only displays if Beckman Coulter enables the optional Test Specific LIH in System Maintenance. Yes: Flags the result with l, i, or h if the level of LIH exceeds the specific limits of the test. If the system does not perform LIH testing on the sample, the system generates an n flag. No: Does not perform test-specific LIH evaluation for the test.
Lipemia	+, ++, +++, +++++, ++++++	If you program Yes in LIH Influence Check , program test-specific LIH criteria from the test-specific reagent IFU.
Icterus		
Hemolysis		

Table 2.11 Test Volume and Methods: ISE Tab Description (Continued)

Item	Contents	Input Notes
Analytical Measuring Range	Low: -9999999 to 9999999 High: Low value to 9999999	Refer to <i>ISE Reagents Instructions for Use</i> . Enter a 7-digit numerical value, not including a minus sign and decimal point. Set the number of decimal places in the Range tab.
Correlation Factor	A: -9999999 to 9999999 B: -9999999 to 9999999	Correlation value = A x (measuring value) + B. Enter a 7-digit numerical value, not including a minus sign and decimal point.

HbA1c Tab



Use this function with the HbA1c reagent (for automated sample preparation) delivered from Beckman Coulter. Use of any other reagent can cause incorrect diagnostic results.

Operation of the three tests 100. HbA1c, 101. T-Hb, and 102. A1c, and some of the specific test parameters are pre-programmed and you cannot change them.

Program HbA1c Tests

Select **CONFIG. > Test Volume and Methods > HbA1c.**

Figure 2.15 Test Volume and Methods: HbA1c Tab

<< Configuration Parameters > Specific Test Parameters > Test Volume and Methods

Test Volume and Methods		Rerun Test Parameters		Rerun Check Parameters	
General	LIH	ISE	HbA1c	Calculated Tests	Range
Operation	No				
	DENAT	101.T-Hb	102.A1c	DENAT	101.T-Hb 102.A1c
Sample Volume	2.0 uL	12.0 uL	6.0 uL	OD Limit	Min.OD
Reagent Volume	R1(R1-1) 200 uL	138 uL	150 uL	Max.OD	
	R2(R2-1) 0 uL	0 uL	30 uL	Reagent OD Limit	1st. Low -2.0000 -2.0000
Wavelength	Pri. ---	570 nm	340 nm	High	3.0000 3.0000
	Sec. ---	660 nm	700 nm	Last Low	-2.0000 -2.0000
Method	---	END	END	High	3.0000 3.0000
Reaction Slope	---	+ -	+ -	Analytical Measuring Range	Low 3.7000 0.1900
Measuring Point-1	1st. ---	0	10	High	13.0000 1.4420
	Last ---	10	27	Correlation Factor	A 1 1 1
Measuring Point-2	1st. ---			B	0 0 0
	Last ---			Manufacturer Factor	A 1 1 1
Linearity Limit	---	%	%	B	0 0 0
Lag Time Check	---			Onboard Stability Period	30 Day
Unit	---				0 Hour

Edit F1
Print F8

Parameters

Specific Test Parameters Menu

Table 2.12 HbA1c Tab Description

Item	Contents	Input Notes
Operation	Yes or No	Select Yes to enable operation for HbA1c analysis. This selection enables operation for tests 100. HbA1c, 101. T-Hb, and 102. A1c. You cannot enable 100. HbA1c, 101. T-Hb, or 102. A1c individually.
Reagent OD Limit	First Low:-2.0000 to 3.0000 High:-2.0000 to 3.0000 Last Low:-2.0000 to 3.0000 High:-2.0000 to 3.0000	
Dynamic Range	Low: -9999999 to 9999999 High: Low value to 9999999	
Correlation Factor	A: -9999999 to 9999999 B: -9999999 to 9999999	Corrects the concentration value with the equation $Y = AX + B$. The system performs the correlation correction after checking the dynamic range.
Manufacturer Factor	Display only	This coefficient corrects the concentration value with the equation of $Y=AX+B$. The system corrects the value before checking the dynamic range. If you program Correlation Factor and Manufacturer Factor , the system calculates the results with both factors. Onboard Stability Period Days (0 to 999) and Hours (0 to 23)

Calculated Tests Tab

Program the calculation parameters for a maximum of 20 calculated tests. Define the calculated test name in the Calculated Tests dialog (**CONFIG. > Test Name Parameters > Test Name > Calculated Tests** [F6]) before it becomes available to enter parameters. When you program, order, and run all the tests in the calculation simultaneously, the system performs the calculated tests and prints them automatically. You can assign a reference interval to the calculated test in the Range screen.

To program the calculated test name, refer to [Test Name Parameters Screen](#).

Select **CONFIG. > Test Volume and Methods > Calculated Tests**.

Figure 2.16 Test Volume and Methods: Calculated Tests Tab

Test Volume and Methods		Rerun Test Parameters		Rerun Check Parameters																																											
General	LIH	ISE	HbA1c	[Calculated Tests]	Range																																										
Calculated Test Name: <input type="text" value="89.%SATr"/> Type: <input type="text" value="Serum"/>																																															
<table style="width: 100%; border-collapse: collapse;"> <thead> <tr> <th style="width: 10%;"></th> <th style="width: 15%;">Test Name</th> <th style="width: 15%;">A</th> <th style="width: 15%;">Constant</th> <th style="width: 15%;">a</th> <th style="width: 15%;">Calculate Type</th> <th style="width: 15%;">Value</th> </tr> </thead> <tbody> <tr> <td></td> <td>A</td> <td><input type="text" value="21.IRON"/></td> <td></td> <td></td> <td><input type="text" value="Value"/></td> <td><input type="text" value="-9999999"/></td> </tr> <tr> <td></td> <td>B</td> <td><input type="text" value="42.UIBCcr"/></td> <td></td> <td></td> <td><input type="text" value="Value"/></td> <td><input type="text" value="9999999"/></td> </tr> <tr> <td></td> <td>C</td> <td><input type="text" value="None"/></td> <td></td> <td></td> <td><input type="text" value="None"/></td> <td><input type="text"/></td> </tr> <tr> <td></td> <td>D</td> <td><input type="text" value="None"/></td> <td></td> <td></td> <td><input type="text" value="None"/></td> <td><input type="text"/></td> </tr> <tr> <td></td> <td>E</td> <td><input type="text" value="None"/></td> <td></td> <td></td> <td><input type="text" value="None"/></td> <td><input type="text"/></td> </tr> </tbody> </table> Formula: <input type="text" value="A/(A+B)*a"/> QC Perform: <input type="text" value="No"/>							Test Name	A	Constant	a	Calculate Type	Value		A	<input type="text" value="21.IRON"/>			<input type="text" value="Value"/>	<input type="text" value="-9999999"/>		B	<input type="text" value="42.UIBCcr"/>			<input type="text" value="Value"/>	<input type="text" value="9999999"/>		C	<input type="text" value="None"/>			<input type="text" value="None"/>	<input type="text"/>		D	<input type="text" value="None"/>			<input type="text" value="None"/>	<input type="text"/>		E	<input type="text" value="None"/>			<input type="text" value="None"/>	<input type="text"/>
	Test Name	A	Constant	a	Calculate Type	Value																																									
	A	<input type="text" value="21.IRON"/>			<input type="text" value="Value"/>	<input type="text" value="-9999999"/>																																									
	B	<input type="text" value="42.UIBCcr"/>			<input type="text" value="Value"/>	<input type="text" value="9999999"/>																																									
	C	<input type="text" value="None"/>			<input type="text" value="None"/>	<input type="text"/>																																									
	D	<input type="text" value="None"/>			<input type="text" value="None"/>	<input type="text"/>																																									
	E	<input type="text" value="None"/>			<input type="text" value="None"/>	<input type="text"/>																																									
Edit F1				Print F8																																											

Table 2.13 Calculated Tests Tab Description

Item	Contents	Input Notes
Calculated Test Name	Calculated test number 1 to 20	Assign a calculated test name to a calculated test number in the Calculated Tests dialog (CONFIG. > Test Name Parameters > Test Name > Calculated Tests [F6]) before it becomes available.
Type	Serum, Urine, Other-1, or Other-2	The sample type.
Test Name	Select the tests involved in the calculation at A, B, C, D, and E.	You can set a maximum of 5 tests.
Constant	<p>If you select Value for Calculate Type, enter a numerical constant (-9999999 to 9999999) in Value for a through d.</p> <p>If you select one of the items from Patient Info.-1 through Patient Info.-6 for Calculate Type, then you can use Patient Information 1 to 6 defined as a Numeric Attribute.</p>	<p>You can set a maximum of 4 constants.</p> <p>Enter a 7-digit numerical value, not including a minus sign and decimal point.</p> <p>You can program patient information in the Sample Program Format screen (CONFIG. > Sample Program Format). Select Numeric Attribute in Attribute to allow entering a numerical value as a patient demographic used as a constant a through d in the calculated test.</p>

Parameters

Specific Test Parameters Menu

Table 2.13 Calculated Tests Tab Description (Continued)

Item	Contents	Input Notes
Formula	Calculated test formula	A maximum of 20 characters. A combination of the characters in +-*/ ()ABCDEabcd
QC Perform	Yes or No	If you select Yes , you can program a QC range for the calculated test in the Check tab (CONFIG. > QC Setup > Check).



Note

The calculation formula uses A to E, arithmetic calculation, and the coefficients a to e. The coefficients can use numerical patient information (for example, weight).

If you select **Yes** for **QC Perform**, you can program a QC range for the calculated test in the Check tab (**CONFIG. > QC Setup > Check**). For example, the QC might be in range for TP and ALB. But if the system performs an albumin and globulin ratio calculation with a QC range programmed, the calculated test QC can be out of range.

If a calculated test generates a rerun flag, or if all tests in the calculated test generate a rerun flag, the system reruns the calculated test. You can program a calculated test to generate ph, pl, P, N, H, L, J, and K flags.

You cannot use color Items, blank Items, LIH, calculated tests, and test numbers of 100, 101, and 102 in the formula.

Range Tab

Program the reference interval values for tests.

The system performs data judgment with the use of numerical values (quantitative method) or flags (qualitative method).

Select **CONFIG. > Test Volume and Methods > Range**.

Figure 2.17 Test Volume and Methods: Range Tab

Table 2.14 Range Tab Description

Item	Contents	Input Notes
Test Name	A test name	
Type	Serum, Urine, Other-1, Other-2, or Whole Blood	
Value/Flag	Value or Flag. For Flag, enter a number (-9999999 to 9999999) for Level: Low and Level: High.	Value: Program a normal reference interval in Specific Ranges (1 to 8) to generate L (low) or H (high) flag on tests. You can program specific reference intervals by sex and age. Flag: Program a range in Low and High of the Level section to generate a P (positive) flag if over the high limit, or N (negative) flag if below the low limit. Typically you program this range for qualitative drugs-of-abuse testing.
Critical Limits	Enter a number (-9999999 to 9999999) for Low and High.	Enter operator-defined critical limits. The system generates a pl flag if the result falls below the low limit, and a ph flag if the result falls above the high limit. It generates an audible alarm if the critical limit is exceeded.
Unit	The units to print on a report.	

Parameters

Specific Test Parameters Menu

Table 2.14 Range Tab Description (Continued)

Item	Contents	Input Notes
Specific Ranges 1 to 8	Low: -9999999 to 9999999 High: Low value to 9999999	<p>A 7-digit numerical value, not including a minus sign and decimal point. Program the number of decimal places in the Decimal Places dialog (Decimal Places [F5]). Program ranges to generate L flags for data less than the low limit or H flags for data greater than the high limit.</p> <p>1 to 6: Enter a reference interval for age, sex, or other type. Program patient demographics to use this feature.</p> <div data-bbox="863 757 1254 808" style="border: 1px solid black; padding: 2px;">  Note </div> <p>Other Type provides the option to program a reference interval other than age and sex. For more information, refer to Other Type.</p> <p>7. Standard demographics: Enter a generic reference interval. Use this range for a sample without patient demographic information (age or sex).</p> <p>8. Not within expected values: Use this range for a sample with patient demographic information (age or sex), but the age or gender information does not satisfy the age and sex defined in 1 to 6.</p>
Decimal Places [F5] displays after selecting Edit [F1].	0 to 4	The decimal places entered affect software prompts and printed results.

Figure 2.18 Set Decimal Places Dialog



Other Type

Other Type provides the option to program a reference interval other than age and sex when using patient demographics.

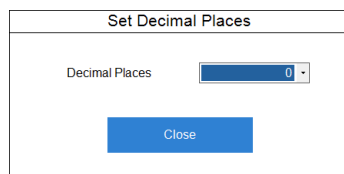
Other Type has six classifications (1 to 6) that can be named in **Other Type** in the Range tab. Refer to [Table 2.13 Range Tab Description](#) for more information.

To activate the Other Type as a reference interval for patient demographics, select **Other Type** in the Sample Program Format screen. For more information, refer to [Sample Program Format Screen](#). You can select the Other Type reference interval when ordering in the Demographics tab (**TEST > Rack (Patient) > Demographics**, or **STAT > STAT (Patient) > Demographics**).

Programmable Ranges and Limits in the General, ISE, and Range Tabs, and the Rerun Test Parameters Screens to Generate Flags

Figure 2.19 Possible Flags in Order of Increasing OD

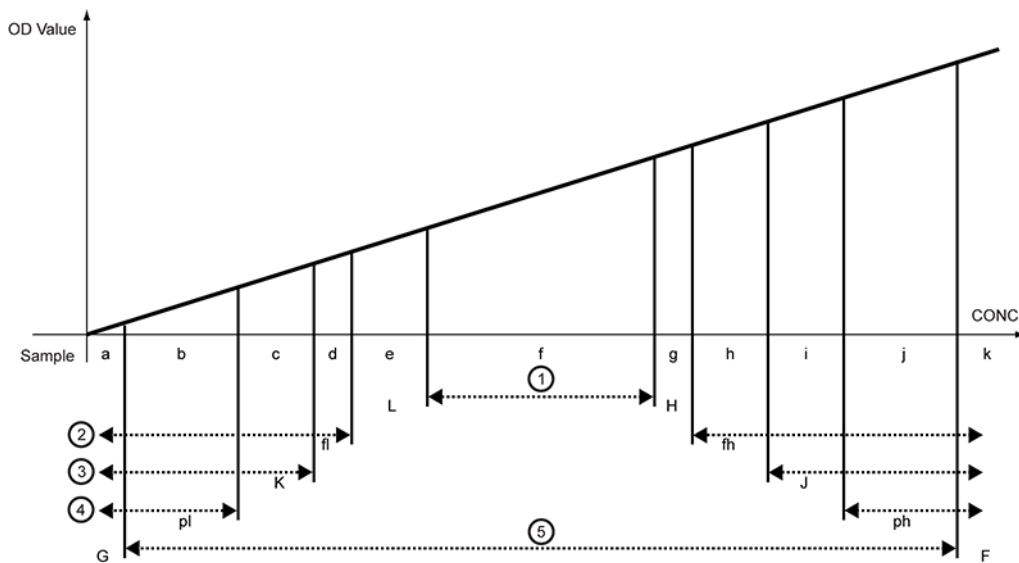

- | | |
|--------------------------|-------------------------------|
| 1. Reference interval | 4. Critical values |
| 2. Reflex values | 5. Analytical measuring range |
| 3. Rerun decision values | |

- Up to 4 flags can be attached to abnormal data according to priority.

Sample	a	b	c	d	e	f	g	h	i	j	k
Flag	G,pl, L,K, (fl)	pl,L, K,fl	L,K, fl	L,fl	L	none	H	H,fh	H,J, fh	ph,H, J,fh	F,ph, H,J,(fh)

- As sample f is within the reference interval, it has no flag.
- The four flags with the highest priorities are displayed on the monitor and are printed on the report next to the result.
- Online parameters can be programmed to transmit two or four result flags. Refer to [Online Menu](#) for more information.
- The rerun decision limits and reflex limits are programmed within the analytical measuring range.

Table 2.16 Screen or Tab to Program Each Range

Contents	Screen or Tab
Reference interval	CONFIG. > Test Volume and Methods > Range
Critical limits	CONFIG. > Test Volume and Methods > Range

Parameters

Specific Test Parameters Menu

Table 2.16 Screen or Tab to Program Each Range (Continued)

Contents	Screen or Tab
Analytical measuring range	CONFIG. > Test Volume and Methods > General and ISE
Rerun Decision limits	CONFIG. > Rerun Test Parameters
Reflex limits	CONFIG. > Rerun Test Parameters

Rerun Test Parameters Screen

The DxC 700 AU allows either manual or automatic rerun sample analysis. This section describes how to program the rerun tests.

Normal rerun:

The analyzer performs analysis with the same parameters used for the first-run analysis.

Rerun with dilution:

The analyzer performs analysis with a pre-dilution or a smaller sample volume than the first run. Pre-dilution means that the system makes a dilution cuvette of sample and diluent on-board the analyzer. The system dispenses the sample from the dilution cuvette into the reaction cuvette.

1. Reduce the sample dispense volume.
2. Increase the dilution ratio.

Rerun with concentration:

The analyzer performs analysis with a larger sample volume than the first-run analysis.

1. Increase the sample dispense volume.
2. Reduce the dilution ratio.

Warning

- With operator-defined parameters, the operator must confirm that the results satisfy the requirements for test performance, including reproducibility and accuracy.
- For best performance, confirm that the measured value with the rerun dilute or condense sample volume and dilution ratio is well within the analytical measuring range of the test.
- When possible, change either the sample volume or the dilution ratio and avoid changing both for dilution or condense.

Note

If the DxC 700 AU is connected to a Laboratory Automation System:

- For samples transported from the Laboratory Automation System, the system queries the Laboratory Information System for the test order and required dilution. The analyzer processes the sample as a first-run sample.
- The system processes samples on the STAT table as rerun samples and can query the Laboratory Information System or use rerun parameters for the rerun order.

Program the sample volume, diluent volume, and pre-dilution rate for a normal rerun, rerun with dilution, and rerun with concentration.

Select **CONFIG. > Rerun Test Parameters**.

Figure 2.20 Rerun Test Parameters Screen

<< Configuration Parameters > Specific Test Parameters > Rerun Test Parameters

Table 2.17 Rerun Test Parameters Screen Description

Item	Contents	Input Notes
Test Name	Test name	
Type	Serum, Urine, Other-1, Other-2, or Whole Blood	
Normal Rerun <ul style="list-style-type: none"> • Sample Volume • Dilution • Pre-Dilution Rate 	Sample Volume, Dilution, and Pre-Dilution Rate display from the General tab (CONFIG. > Test Volume and Methods > General).	

Parameters

Specific Test Parameters Menu

Table 2.17 Rerun Test Parameters Screen Description (Continued)

Item	Contents	Input Notes
Rerun with diluent and Rerun with concentration <ul style="list-style-type: none"> • Sample Volume • Dilution 	<ul style="list-style-type: none"> • If Dilution is 0 μL, then you can set the sample volume between 1.0 μL and 25.0 μL. • If Dilution is 10 μL, then you can set the sample volume between 1.0 μL and 20.0 μL. • The minimum sample volume is 1.0 μL. 	You can set Sample Volume in increments of 0.1 μL . The system uses deionized water (0 or 10 μL) dispensed for a sample dilution following the sample dispense.
Pre-Dilution Rate	1, 3, 5, 10, 15, 20, 25, 50, 75, 100	Defines the automatic pre-dilution rate. The system uses two cuvettes for dilution and reaction for a test. First the analyzer performs sample dilution with deionized water or other diluent in a dilution cuvette, then dispenses the test sample volume from the dilution cuvette into a reaction cuvette. Refer to Pre-Dilution Rate Volumes for the sample volumes required for each pre-dilution rate.
Rerun Decision Limits Low and High	A number (-9999999 to 9999999)	Operator-defined limits to generate a rerun order. Results below the low limit generate a K flag. Results above the high limit generate a J flag.
Reflex Limits Low and High	A number (-9999999 to 9999999)	Operator-defined limits to generate the reflex testing. Results below the low limit generate an fl flag. Results above the high limit generate an fh flag. The system uses these limits to automatically order related tests when the deciding test results in either of these flags. Program the deciding test and related tests in the Reflex tab (CONFIG. > Rerun Check Parameters > Reflex).

Table 2.17 Rerun Test Parameters Screen Description (Continued)

Item	Contents	Input Notes
Analytical Measuring Range Error Rerun Operation	Yes or No	<p>If you select Yes, a test generates a F, G, Fx, or Gx flag, and you select the corresponding flag in the Flag tab (CONFIG. > Rerun Check Parameters > Flag), the system reruns the test.</p> <p>If you select No, a test generates a F, G, Fx, or Gx flag, and you select the corresponding flag in the Flag tab (CONFIG. > Rerun Check Parameters > Flag), the system does not rerun the test and always reports concentration values, even if they are above the analytical measuring range.</p> <p>The default setting is Yes.</p>

Rerun Check Parameters Screen

Flag Tab

Select **CONFIG. > Rerun Check Parameters > Flag**.

Figure 2.21 Rerun Check Parameters: Flag Tab

<< Configuration Parameters > Specific Test Parameters > Rerun Check Parameters

Test Volume and Methods	Rerun Test Parameters	Rerun Check Parameters												
<div style="border: 1px solid black; padding: 5px;"> <div style="display: flex; justify-content: space-between;"> Flag Reflex </div> <div style="display: flex; justify-content: space-between; margin-top: 10px;"> Auto Rerun Order: Yes Rerun Data Over-Writes First-Run Data Automatically: No </div> <div style="margin-top: 10px;"> <p>Select Flag</p> <table border="1" style="width: 100%; border-collapse: collapse; text-align: center;"> <tr> <td style="width: 30%;">Rerun when any selected flag occurs.</td> <td>(Wa R # % ? y u @ \$ D B * & Z E Fx Gx I) a ba bh bn bz F G Tx ph pl T P N H L J K /</td> </tr> <tr> <td>Rerun when all selected flags occur.</td> <td>(Wa R # % ? y u @ \$ D B * & Z E Fx Gx I) a ba bh bn bz F G Tx ph pl T P N H L J K /</td> </tr> <tr> <td>Rerun with diluent when any selected flag occurs.</td> <td>(Wa R # % ? y u @ \$ D B * & Z E Fx Gx I) a ba bh bn bz F G Tx ph pl T P N H L J K /</td> </tr> <tr> <td>Rerun with diluent when all selected flags occur.</td> <td>(Wa R # % ? y u @ \$ D B * & Z E Fx Gx I) a ba bh bn bz F G Tx ph pl T P N H L J K /</td> </tr> <tr> <td>Rerun with concentration when any selected flag occurs.</td> <td>(Wa R # % ? y u @ \$ D B * & Z E Fx Gx I) a ba bh bn bz F G Tx ph pl T P N H L J K /</td> </tr> <tr> <td>Rerun with concentration when all selected flags occur.</td> <td>(Wa R # % ? y u @ \$ D B * & Z E Fx Gx I) a ba bh bn bz F G Tx ph pl T P N H L J K /</td> </tr> </table> </div> </div>			Rerun when any selected flag occurs.	(Wa R # % ? y u @ \$ D B * & Z E Fx Gx I) a ba bh bn bz F G Tx ph pl T P N H L J K /	Rerun when all selected flags occur.	(Wa R # % ? y u @ \$ D B * & Z E Fx Gx I) a ba bh bn bz F G Tx ph pl T P N H L J K /	Rerun with diluent when any selected flag occurs.	(Wa R # % ? y u @ \$ D B * & Z E Fx Gx I) a ba bh bn bz F G Tx ph pl T P N H L J K /	Rerun with diluent when all selected flags occur.	(Wa R # % ? y u @ \$ D B * & Z E Fx Gx I) a ba bh bn bz F G Tx ph pl T P N H L J K /	Rerun with concentration when any selected flag occurs.	(Wa R # % ? y u @ \$ D B * & Z E Fx Gx I) a ba bh bn bz F G Tx ph pl T P N H L J K /	Rerun with concentration when all selected flags occur.	(Wa R # % ? y u @ \$ D B * & Z E Fx Gx I) a ba bh bn bz F G Tx ph pl T P N H L J K /
Rerun when any selected flag occurs.	(Wa R # % ? y u @ \$ D B * & Z E Fx Gx I) a ba bh bn bz F G Tx ph pl T P N H L J K /													
Rerun when all selected flags occur.	(Wa R # % ? y u @ \$ D B * & Z E Fx Gx I) a ba bh bn bz F G Tx ph pl T P N H L J K /													
Rerun with diluent when any selected flag occurs.	(Wa R # % ? y u @ \$ D B * & Z E Fx Gx I) a ba bh bn bz F G Tx ph pl T P N H L J K /													
Rerun with diluent when all selected flags occur.	(Wa R # % ? y u @ \$ D B * & Z E Fx Gx I) a ba bh bn bz F G Tx ph pl T P N H L J K /													
Rerun with concentration when any selected flag occurs.	(Wa R # % ? y u @ \$ D B * & Z E Fx Gx I) a ba bh bn bz F G Tx ph pl T P N H L J K /													
Rerun with concentration when all selected flags occur.	(Wa R # % ? y u @ \$ D B * & Z E Fx Gx I) a ba bh bn bz F G Tx ph pl T P N H L J K /													
Edit F1		Print F8												

Parameters

Specific Test Parameters Menu

Table 2.18 Flag Tab Description

Item	Contents	Input Notes
Auto Rerun Order	Yes or No	Select Yes to generate automatic rerun orders. If you select No , you must retrieve the rerun orders in the Rerun dialog (TEST > Rack (Patient) > Test Order > Rerun [F3]) or (STAT > STAT (Patient) > Test Order > Rerun [F3]).
Rerun Data Over-Writes First-Run Data Automatically	Yes or No	Select Yes to automatically over-write first-run data with rerun data. Select No to review the first-run data and rerun data before over-writing.
Rerun when any selected flag occurs.	Select the flags to generate a rerun order.	The system issues a rerun order when it generates any of the highlighted flags.
Rerun when all selected flags occur.	Select a flag to generate a rerun order.	The system issues a rerun order only when it generates all highlighted flags.
Rerun with diluent when any selected flag occurs.	Select a flag to generate a rerun order.	The system issues a rerun dilution order when it generates any of the highlighted flags.
Rerun with diluent when all selected flags occur.	Select a flag to generate a rerun order.	The system issues a rerun dilution order only when it generates all highlighted flags.
Rerun with concentration when any selected flag occurs.	Select a flag to generate a rerun order.	The system issues a rerun condense order when it generates any of the highlighted flags.
Rerun with concentration when all selected flags occur.	Select a flag to generate a rerun order.	The system issues a rerun condense order only when it generates all highlighted flags.

You can select the same flag for only one of the following options. The last option selected is programmed.

- Rerun when any selected flag occurs
- Rerun with diluent when any selected flag occurs
- Rerun with concentration when any selected flag occurs

Selecting the same combination of flags in these three options generates an error message when you select **Save [F1]**:

- Rerun when all selected flags occur
- Rerun with diluent when all selected flags occur
- Rerun with concentration when all selected flags occur

Select **Cancel** to resolve the error. If you select **OK** with the error unresolved, the analyzer cannot start analysis.

For more information on flags, refer to the *DxC 700 AU Instructions for Use*.

If any test in the calculation generates a rerun flag, the system reruns all tests programmed as part of the calculated test. If you program the flag to rerun with a dilution, then the system dilutes that test. Other tests in the calculation without rerun flags rerun with first-run sample volumes.

Reflex Tab

Program a deciding test and a maximum of five related tests as a group for reflex testing. When the deciding test causes a rerun, fl, or fh flag, the system automatically orders the related tests for rerun analysis. The system also orders the deciding test with a rerun flag, but not with a fl or fh flag.

For example, if you program ALB as the Deciding Test and TP as the Related Test, the system orders both ALB and TP for rerun analysis when the system generates a rerun flag on ALB. However, when the system generates a fl or fh flag on ALB, the system orders only TP, and not ALB.

You can program a maximum of 10 reflex groups.



Note

If a result does not fall within the Reflex Range programmed in the Rerun Test Parameters screen (**CONFIG. > Rerun Test Parameters**), the system generates a fh or fl flag.

Select **CONFIG. > Rerun Check Parameters > Reflex**.

Figure 2.22 Rerun Check Parameters: Reflex Tab

<< Configuration Parameters > Specific Test Parameters > Rerun Check Parameters

Test Volume and Methods		Rerun Test Parameters		Rerun Check Parameters		
Flag	Reflex					
No.	Deciding Test	Related Test				
		1	2	3	4	5
1	9.TBILC	7.DBILC	None	None	None	None
2	33.TRIG	44.LDL-G	None	None	None	None
3	None	None	None	None	None	None
4	None	None	None	None	None	None
5	None	None	None	None	None	None
6	None	None	None	None	None	None
7	None	None	None	None	None	None
8	None	None	None	None	None	None
9	None	None	None	None	None	None
10	None	None	None	None	None	None

Edit F1
Print F8

Parameters

Calibration Setup Menu

Table 2.19 Reflex Tab Description

Item	Contents	Input Notes
Deciding Test	Name of test	Generates an automatic rerun order for the related tests when it causes fl, fh, or other rerun flags on the deciding test. The system generates the rerun order for the deciding test when the rerun flag is generated, but does not generate the rerun order for the deciding test when the fl or fh flag is generated.
Related Test	Name of test	Generates an automatic rerun order for the related test when it causes a rerun, fl, or fh flag on the deciding test.

Calibration Setup Menu

Program the calibrators used for calibration analysis and the calibration parameters.

You typically assign calibrators to positions in the yellow rack, or you enable calibrator bar code operation and place the calibrators in any position in the yellow rack.

You can assign calibrators to positions on the STAT table, or you can enable calibrator bar code operation and place the calibrators in any Free position on the STAT table.



Note

If the DxC 700 AU connects to a Laboratory Automation System, you must enable calibrator bar code operation and perform calibration from the STAT table.



Caution

Incorrect calibration parameters cause errors in analysis results, and can cause misdiagnosis. Visually confirm specific test calibration parameter settings against the published settings, and through analysis using Quality Control materials.

For more information on displaying a list of set values, refer to [Calibration Setup: General Tab](#).

Calibrators Tab

Program a maximum of 200 calibrators required for specific tests programmed on the system. Beckman Coulter programs calibrators to a type (Serum, Urine, Other-1, Other-2, or Whole Blood), as determined by laboratory requirements.

Select **CONFIG. > Calibration Setup > Calibrators**.

Figure 2.23 Calibration Setup: Calibrators Tab

<< Calibration > Calibration Setup

Calibration Monitor		ISE Calibration		Calibration Setup		
Calibrators		General		ISE		
<input type="checkbox"/> Bar Code Operation						
No.	Cup Position	Type	Calibrator		Lot No.	Expiration
			Name	ID		
1	0001-01	Serum	Cal Level 1	DR0070-1	6102K11	07/31/2016
2	0001-02	Serum	Cal Level 2	DR0070-2	6102K11	07/31/2016
3	0001-03	Serum	CO2 20	2340-C	59722875	07/31/2016
4	0001-04	Serum	CO2 40	2340-E	59722877	07/31/2016
5	0001-05	Serum	HDL CAL	GENZYME 80-6449-00	803091	07/05/2016
6	0001-06	Serum	FRUCTOSAMINE CAL	ROCHE	159243-02	07/13/2016
7	0001-07	Serum	LIPASE CAL	IN KIT	2321	07/01/2016
8	0001-08	Serum	LDL CALIBRATOR	GENZYME 80-5666-02	805885	08/09/2016
9	0001-09	Serum	BETA-HYDROXYBUTYRATE	BHB	113071CE	08/31/2016
10	0001-10	Serum				
11	0002-01	Serum				
12	0002-02	Serum				

<RB Sample Information>

No.	Name	ID	Serum	Urine	Other-1	Other-2
1	DI Water		<input checked="" type="checkbox"/>	<input checked="" type="checkbox"/>	<input checked="" type="checkbox"/>	<input checked="" type="checkbox"/>
2			<input type="checkbox"/>	<input type="checkbox"/>	<input type="checkbox"/>	<input type="checkbox"/>

Edit F1	Calibrator Info, Loading History F3	Set Conc Value F5	Print F8
------------	-------------------------------------------	----------------------	-------------

Table 2.20 Calibrators Tab Description

Item	Contents	Input Notes
Bar Code Operation	Selected or Cleared	To use a calibrator bar code, select Bar Code Operation . Enter a calibrator ID or scan the calibrator bar code ID into the ID field. In bar code operation, you can place calibrators in any position in the yellow rack. If Bar Code Operation is cleared, you assign calibrators to positions in the yellow rack.
Cup Position	Cup Position	Display only. If you select Bar Code Operation , nothing displays. If Bar Code Operation is cleared, the system displays the cup positions on the rack.
Type	Sample Type	Display only. The system displays the sample type (Serum, Urine, Other-1, Other-2, or Whole Blood).
Name	Calibrator name	A maximum of 20 characters.
ID	Calibrator ID (bar code)	When you select Bar Code Operation , a maximum of 26 alphanumeric characters for the calibrator ID. You can enter a calibrator ID or scan the calibrator bar code ID.
Lot No.	Calibrator lot number	A maximum of 15 alphanumeric characters.
Expiration	Calibrator expiration date	Enter a date, for example YYYY/MM/DD.

Parameters

Calibration Setup Menu

Table 2.20 Calibrators Tab Description (Continued)

Item	Contents	Input Notes
RB Sample Information	Reagent blank number, name, ID, and sample type	You can define two types of reagent blank material (No. 1 and No. 2). All tests use deionized water, typically assigned to position 1. Select Serum, Urine, Other-1, Other-2, or Whole Blood , for No. 1 . Enter a reagent blank name (a maximum of 20 characters), typically deionized water. Enter a reagent blank ID (a maximum of 26 characters) if you select Bar Code Operation .
Calibrator Info Loading History [F3]	History records of the calibrator measured on the system.	Display only. You can confirm the calibrator that was used on the system in the past.
Set Conc Value [F5]	Calibrator concentration	Use it to enter calibrator concentrations for a new lot number. For tests with a multi-point calibration curve, confirm the concentration of all calibrator levels.



Note

You can set the reagent blank for each sample type.

When you select **No. 1**, set the cup in the first cup position of the blue rack or the RB1 position on the STAT table.

When you select **No. 2**, set the cup in the second cup position of the blue rack or the RB2 position on the STAT table.

If the DxC 700 AU connects to a Laboratory Automation System, you must perform reagent blanks from the STAT table. Set the reagent blank No. 1 in position RB1 and reagent blank No. 2 in position RB2 on the STAT table.

Calibration Setup: General Tab

Program all specific calibration parameters for each test. Program and confirm the information from the reagent setting sheet for the test.

Select **CONFIG. > Calibration Setup > General**.

Figure 2.24 Calibration Setup: General Tab

Table 2.21 Calibration Setup: General Tab Description

Item	Contents	Input Notes
Test Name	Test name	
Type	Serum, Urine, Other-1, Other-2, or Whole Blood	
Use Serum Cal.	Selected or Cleared	Select this option to use the Serum calibration curve for the Urine, Other-1, or Other-2 test. The system does not calibrate Urine, Other-1, or Other-2 test.
Calibration Type	MB to 7 MB, AA, AB to 7 AB, 4 MC to 10 MC	Enter the calibration type from the reagent setting sheet. For a description of the different calibration types, refer to Summary of Calibration Types .
Formula	Interpolation formula for the calibration curve.	Select the formula from the reagent setting sheet. The calibration type limits the formulas that you can select for a test.
Counts	1, 2, 3, or 4	The quantity of reagent blank and calibration replicates used for calculation. If you select 1 , the system uses the reagent blank or calibrator OD for calculation. If you select 2 , the system uses the mean value of the replicates. If you select 3 , the system use the mean value of the two closest replicates. If you select 4 , the system uses the highest and lowest replicate values, and it uses the mean value of the two replicates.

Parameters

Calibration Setup Menu

Table 2.21 Calibration Setup: General Tab Description (Continued)

Item	Contents	Input Notes
Slope Check	+ or -	Refer to the reagent setting sheet. For multi-point calibrations (AA and 2 AB to 7 AB) the software checks to confirm that all OD values are increasing (+) or decreasing (-).
Allowable Range Check: Reagent Blank	OD value (0.0000 to 3.0000)	Refer to the reagent setting sheet. An acceptable dispersion of OD values (OD delta check) for the reagent blank for AA, AB to 7AB, and 4MC to 10MC.
Allowable Range Check: Calibration	OD value (0.0000 to 3.0000)	Refer to the reagent setting sheet. An acceptable dispersion of OD values (OD delta check) for the calibration for AA, AB to 7AB, and 4MC to 10MC.
Advanced Calibration: Operation	Yes or No	Refer to the reagent setting sheet. Advanced calibration allows reagent blank and calibration for up to 5 bottles or lot numbers of the same test.
Advanced Calibration: Interval (RB)	Bottle or Lot	
Advanced Calibration: Interval (ACAL)	Bottle, Lot, or None	
Stability: Reagent Blank and Calibration	0 to 999 (Day) and 0 to 23 (Hour)	
MB Type Factor	Factor value (-9999999 to 9999999)	For MB calibration type, enter the factor value. Refer to the reagent setting sheet.
1-Point Calibration Point	Calibrator Point-1 to Point-7	For a multi-point calibration, enter the calibrator number to adjust the multi-point calibration curve by a single point.
with Conc-0	Selected or Cleared	Select this option for a multi-point calibration to include the zero concentration. If 1-Point Calibration Point is used and zero concentration is the origin, select Conc-0 and enter the calibrator number in 1-Point Calibration Point .
Calibrator	Calibrator name	To display the calibrator name, program the calibrator in the Calibrators tab (CONFIG. > Calibration Setup > Calibrators).
OD	OD value	Enter the OD (-2.0000 to 3.0000) for calibration types 2 MB to 7 MB.
Conc	Calibrator concentration	A maximum of 9 digits including the decimal point and minus sign, from -9999999 to 9999999.

Table 2.21 Calibration Setup: General Tab Description (Continued)

Item	Contents	Input Notes
Factor Range or OD Range	OD range: -2.0000 to 3.0000 Factor range: -9999999 to 9999999	Refer to the reagent setting sheet. When the calibration type is 2AB to 7AB, you can program an OD Range. When the calibration type is AB or AA, you can program a Factor Range. Exceeding the range generates a Calibration Factor/OD Range event.
Factor Display [F5]	Calibration factor and curve	Display only. You can confirm that the calibration factor and the calibration curve for the Calibration type are 2 MB to 7 MB.
Conc. List [F6]		
List Display [F7]	Displays a list of all test parameters configured in Calibration Setup > General .	Use the list to confirm parameters. Select the sample type, and a maximum of six tests to display at a time.
Print [F8]		

Advanced Calibration

Advanced Calibration allows calibration of up to 5 bottles or lot numbers of the same reagent before the patient run. When the system switches to a new bottle or lot number for a reagent, the system uses the correct calibration curve. You can use Advanced Calibration for reagent ID positions, or fixed (assigned) positions. For more information, contact Beckman Coulter.

Calibration Setup: ISE Tab

Program specific calibration parameters for the ISE tests (Na, K, and Cl).

Select **CONFIG. > Calibration Setup > ISE**.

Parameters

Calibration Setup Menu

Figure 2.25 Calibration Setup: ISE Tab

Calibration Monitor		ISE Maintenance		Calibration Setup	
Calibrators	General	ISE			
Type	Serum				
Test Name	97 Na	98 K	99 Cl		
Calibration Type	MCAL				
Counts					
MCAL Factor Type	Manual				
Cell 1					
MCAL Factor-A	1.000	1.000			1.000
MCAL Factor-B	0.000	0.000			0.000
ISE Correction Type	Offset				
Calibrator					
Conc.					
Factor Range Low					
Factor Range High					
Allowable Range Check					
Allowable Range Check Value					
Edit F1					Print F8

Table 2.22 Calibration Setup: ISE Tab Description

Item	Contents	Input Notes
Type	Serum or Urine	
Calibration Type	MCAL or ACAL	Selecting MCAL means that the system performs ISE calibration using the Serum or Urine Standard Solution H and L and the calibration is monitored from the Calibration tab (MAINT. > ISE Maintenance > Calibration). Selecting ACAL means that the system calibrates from calibrator in the yellow rack or STAT table. Programming MCAL or ACAL applies to all three ISE tests (Na, K, and Cl).
Counts	1 to 4	If you select ACAL , select the quantity of calibration replicates.
MCAL Factor Type	Manual or CRS Calibration	CRS calibration is only available in Japan.

 **Note**

It is only possible to select **Calibrator**, **Conc**, **Factor Range Low**, **Factor Range High**, **Allowable Range Check**, and **Allowable Range Check Value** if you program the calibration type to **ACAL**.

Table 2.23 Calibration Setup: ISE Tab Description for ACAL

Item	Contents	Input Notes
Calibrator	Calibrator for Na, K, and Cl	Select the calibrator to use for Na, K, and Cl.

Table 2.23 Calibration Setup: ISE Tab Description for ACAL (Continued)

Item	Contents	Input Notes
Conc	Calibrator concentration	Enter the calibrator concentration for Na, K, and Cl (-9999999 to 9999999).
Factor Range Low and Factor Range High	Factor range	Enter the calibration low factor limit (-9999999) to high factor limit (9999999) for Na, K, and Cl.
Allowable Range Check	Yes or No	Select Yes to perform an OD delta check on the calibrator OD values.
Allowable Range Check Value	OD value	If you select Yes in Allowable Range Check , enter the OD value for the OD delta check.

QC Setup Menu

Program the controls used for QC analysis, and all specific QC parameters.

Quality control (QC) samples, necessary for any diagnostic device, confirm system performance.

Check the performance of the DxC 700 AU regularly by analyzing control samples. Establish a control frequency for your laboratory. If feasible, test control samples each time you test patient samples and calibrate. If you detect any trends or sudden shifts in values, review all operating parameters.

Establish guidelines for your laboratory to take corrective action in case controls do not fall within the specified control limits.

You can perform QC analysis in the green racks or the STAT table. When you enable QC Bar Code Operation, you can place controls in any position in the green racks or STAT table.

If the DxC 700 AU connects to a Laboratory Automation System, you must enable QC bar code operation and perform QC analysis from the STAT table.



Erroneous analysis data can cause erroneous diagnosis results. Always perform QC analysis at the same time as analysis of general patient samples to confirm normal analysis.

Controls Tab

Program a maximum of 100 controls required for specific tests. Beckman Coulter programs control numbers to a type (Serum, Urine, Other-1, Other-2, or Whole Blood), as determined by laboratory requirements.

Select **CONFIG. > QC Setup > Controls**.

Figure 2.26 QC Setup: Controls Tab

<< Quality Control > QC Setup

Chart		Twin Plot Chart		QC Setup		
Controls		Check	Preset	Cumulative		
<input checked="" type="checkbox"/> Bar Code Operation						
No.	Cup Position	Type	Control		Lot No.	Expiration
			Name	ID		
1		Serum	Biorad Liquicheck 1	0000010511	16641	11/30/2016
2		Serum	Biorad Liquicheck 2	0000010512	16642	11/30/2016
3		Serum	Biorad Lipid 1	0000010513	57251	09/30/2016
4		Serum	Biorad Lipid 2	0000010514	57252	09/30/2016
5		Serum	Biorad Immuno 1	0000011515	40251	02/28/2017
6		Serum	Biorad Immuno 3	0000011516	40253	02/28/2017
7		Serum				
8		Serum				
9		Serum				
10		Serum				
11		Serum				
12		Serum				

Edit F1 Set Controls F5 Print F8

Table 2.24 Controls Tab Description

Item	Contents	Input Notes
Bar Code Operation	Selected or Cleared	If you select Bar Code Operation , the system assigns control IDs to control materials, and you can place controls in any position in the green rack or STAT table. If Bar Code Operation is cleared, you assign controls to positions in the green rack or STAT table.
Cup Position	Cup Position	Display only. If you select Bar Code Operation , nothing displays. If Bar Code Operation is cleared, the system displays the cup positions on the rack.
Type	Sample Type	Display only. The system displays the sample type (Serum, Urine, Other-1, Other-2, or Whole Blood).
Name	Control name	A maximum of 20 characters.
ID	Control ID (bar code)	When you select Bar Code Operation , a maximum of 26 alphanumeric characters for the control ID.
Lot No.	Control lot number	A maximum of 15 alphanumeric characters.
Expiration	Control expiration date	Enter a date.

Check Tab

Program the specific control parameters for each test.

Two quality control methods are:

- Single check, which uses the mean value and the standard deviation of the control
- Multi check, with multiple rules, including the tendencies of past results in the control

You can evaluate QC using Preset mode or Cumulative mode. In Preset mode, you enter the QC mean, SD, and range in the Preset tab. In Cumulative mode, the system calculates the QC mean, SD, and range from QC run on the analyzer.

For more information, refer to [Quality Control](#).

Select **CONFIG. > QC Setup > Check**.

Figure 2.27 QC Setup: Check Tab

Table 2.25 Check Tab Description

Item	Contents	Input Notes
Test Name	Test name	
Single Check Level	1SD, 2SD, 3SD, or 4SD	The system checks the standard deviation as the control limit. Set the deviation level (1SD to 4SD). The flag is 1Q for any QC value that exceeds the SD level selected.

Table 2.25 Check Tab Description (Continued)

Item	Contents	Input Notes
Multi Check Level	Check 1 _{2s} , 1 _{3s} , 2 _{2s} , R _{4s} , 4 _{1s} , Nx, and/or Trend Check	<ul style="list-style-type: none"> • If you select 1_{2s} and the control data on one side exceeds +/- 2SD, the system generates a 1Q flag is generated. • If you select 1_{3s} and the control data on one side exceeds +/- 3SD, the system generates a 2Q flag. • If you select 2_{2s} and two consecutive control data exceed +/- 2SD in the same direction, the system generates a 3Q flag. • If you select R_{4s} and consecutive high and low control data exceeds + 2SD and - 2SD, the system generates a 4Q flag. • If you select 4_{1s} and four consecutive control data exceed +/- 1SD in any direction, the system generates a 5Q flag. • If you select Nx, program from 7 to 10 points to check if consecutive control data is above or below the mean value. The system generates a 6Q flag. • If you select Trend Check, program from 4 to 10 points to check for consecutively increasing or decreasing values. The system generates a 7Q flag. <p>When using Multi Check, select 1_{2s} to initiate the process to implement the following checks when the data exceeds 1_{2s}.</p>
QC Mode	Off, Preset, or Cumulative	<ul style="list-style-type: none"> • If you select Off, the system does not perform a QC check and does not generate QC events and flags. • If you select Preset, the system generates QC events and flags from the values programmed in the Preset tab. • If you select Cumulative, the system generates QC events and flags from the calculated QC values obtained from the analyzer. You can calculate the QC mean, standard deviation, and range in the Cumulative tab. <p>The system does not calculate the QC value automatically.</p>

Preset Tab

When you use Preset mode, enter known values for the mean, SD, and range. You can program a maximum of 10 controls for each test and sample type.

Select **CONFIG.** > **QC Setup** > **Preset.**

Figure 2.28 QC Setup: Preset Tab

Level	Control	Multi/Single	Mean	SD	Range
1	1.BioRad Multiquial 1	Single	2.45	0.125	0.5
2	2 BioRad Multiquial 3	Single	4.10	0.200	0.8
3	None				
4	None				
5	None				
6	None				
7	None				
8	None				
9	None				
10	None				

Table 2.26 Preset Tab Description

Item	Contents	Input Notes
Test Name	Test name	
Type	Serum, Urine, Other-1, Other-2, or Whole Blood	
Control	Control material	Select the control material from the available control materials programmed in the Controls tab (CONFIG. > QC Setup > Controls).
Multi/Single	Multi or Single	Program each control to use Single Check or Multi Check rules. For Multi Check rules to evaluate QC data correctly, program two control materials for the test.
Mean	QC mean value	
SD	Standard deviation	Enter the value of one standard deviation.
Range	Range value	Enter the value of the range for acceptable QC.
QC Stack Review [F7]	Displays the last 10 QC results for the low and high control for the test.	QC data only displays if you select Multi to program the test. Select Close to close the dialog.

Parameters
QC Setup Menu

Figure 2.29 QC Stack Review Dialog

 **Note**

You can program for QC on calculated tests only controls that are common to all tests in the calculation.

If you select **Multi** for two controls, you can display the Twin Plot chart in the Twin Plot Chart screen (**QC > Twin Plot Chart**).

Cumulative Tab

When you select **Cumulative** for **QC Mode** in the Check tab, the system calculates QC mean, standard deviation, and range from QC data run on the analyzer.

Select **CONFIG. > QC Setup > Cumulative**.

Figure 2.30 QC Setup: Cumulative Tab

Level	Control	Multi/Single	N	Mean	SD	Range
1	1.BioRad Multiqua 1	Single				
2	2.BioRad Multiqua 3	Single				
3	None					
4	None					
5	None					
6	None					
7	None					
8	None					
9	None					
10	None					

Table 2.27 Cumulative Tab Description

Item	Contents	Input Notes
Test Name	Test name	
Type	Serum, Urine, Other-1, Other-2, or Whole Blood	
Control	Control material	Select the control material. Program the available control materials in the Controls screen.
Multi/Single	Multi or Single	Program each Control to use Single Check or Multi Check rules. For Multi Check rules to properly evaluate QC data, program two control materials for the test.
Period of Cumulation	Displays the values that you select for Start Index and End Index for the calculation of QC statistics in the Adds to Cumulative dialog.	
Adds to Cumulative [F5]	Displays the Adds to Cumulative dialog to set the start index and end index to calculate QC statistics.	Adds QC data from the selected start index and end index to any existing QC statistics, and calculates a new QC mean, SD, and range. When you select OK , the system calculates and displays the number of QC data points (N), QC mean, SD, and range.
New Cumulative [F6]	Start index and end index to calculate QC statistics.	Calculates a new QC mean, SD, and range using data between the start index and end index. When you select OK , the system calculates and displays the number of QC data points (N), QC mean, SD, and range.
QC Stack Review [F7]	Displays the last 10 QC results for the low and high control for the test.	QC data only displays if you select Multi to program the test. Select Close to close the dialog.

Figure 2.31 New Cumulative Dialog

New Cumulative

Create the cumulative data by the following data?

Start Index: 300.03/21/2015 06:10

End Index: 2.08/27/2015 23:06

OK Cancel

Figure 2.32 Adds to Cumulative Dialog

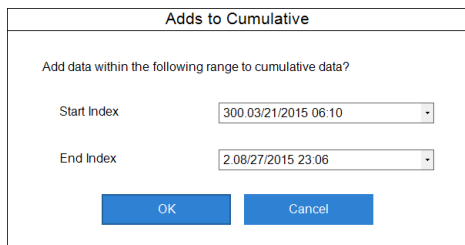

 **Note**

You can program for QC on calculated tests only the controls that are common to all tests in the calculation.

If you select **Multi** for two controls, you can display the Twin Plot chart in the Twin Plot Chart screen (**QC > Twin Plot Chart**).

STAT Table Setup

STAT Table Setting Dialog

When you perform patient sample analysis, calibration, or QC from the STAT table, program the STAT table settings beforehand.

 **Important**

With Multiple Loads STAT Table operation, the system selects **Bar Code** for all sample kinds in the **[STAT Test Order]** section and **Free** for all positions in the STAT table position settings.

The setting is not programmable.

Select **STAT > STAT Status > STAT Table Setting** [F6]. The system displays the STAT Table Setting dialog.

Figure 2.33 STAT Table Setting Dialog

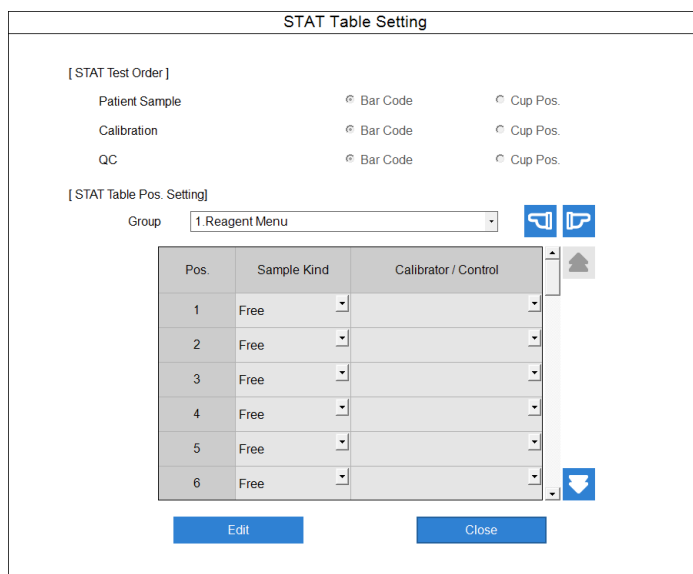

Table 2.28 STAT Table Setting Dialog: STAT Test Order Description

Item	Contents	Input Notes
Patient Sample	Bar Code or Cup Pos.	
Calibration	Bar Code or Cup Pos.	
QC	Bar Code or Cup Pos.	

Table 2.29 STAT Table Setting Dialog: STAT Table Pos. Setting Description

Item	Contents	Input Notes
Group	Group 1, 2, or 3	Select 1 , 2 , or 3 to program the STAT Table position for the Group.
Pos.	STAT position number	Not programmable.
Sample Kind	Free, Patient, Cal., or QC	<p>Select Free when you select Bar Code in the [STAT Test Order] section of the STAT Table Setting dialog.</p> <p>You can place all bar-coded sample kinds in a position assigned as Free.</p> <p>Select Patient, Cal., or QC when you select Cup Pos. in the [STAT Test Order] section of the STAT Table Setting dialog.</p> <p>You can place patient samples only in positions for which you select Patient, calibrators only in positions for which you select Cal., and control samples only in positions for which you select QC.</p>

Table 2.29 STAT Table Setting Dialog: STAT Table Pos. Setting Description (Continued)

Item	Contents	Input Notes
Calibrator/Control	Free or the name of a calibrator	Programmable when the sample kind is calibrator. Select Free or a specific calibrator. If you select Free , the system automatically assigns a calibrator when you order the calibration in the STAT (Calibration) tab. If you select a calibrator, the system reserves the position for the selected calibrator.
	Free or the name of a control	Programmable when the sample kind is QC. Select Free or a specific control. If you select Free , the system automatically assigns a control when you order the QC in the STAT (QC) tab. If you select a control, the system reserves the position for the selected control.

Auto ACAL/QC Setup Screen

Auto ACAL/QC Setup: ACAL Tab

Programming **Yes** in the ACAL tab makes automatic STAT calibration available. When the event programmed for **Execution Type** occurs during sample analysis, and the STAT table contains all necessary calibrators, the system performs automatic STAT calibration.

If you program automatic STAT calibration, the amber STAT TABLE ROTATION LED continuously blinks slowly during analysis.

If you use Quick STAT analysis, or Multi STAT table operation, program **No** for all items in the Auto ACAL/RB column.

Select **CONFIG. > Auto ACAL/QC Setup > ACAL.**

Figure 2.34 Auto ACAL/QC Setup: ACAL Tab

Test Name	Available/Unavailable	Auto ACAL/RB	RB Execution Type	ACAL Execution Type
11.TP	Available	No	Change Lot No.	None
97.Na	Unavailable	No	Change Lot No.	None
98.K	Unavailable	No	Change Lot No.	None
99.Cl	Unavailable	No	Change Lot No.	None
18.CO2	Available	No	Change Lot No.	None
15.AST	Available	No	Change Lot No.	None
8.BUN	Available	No	Change Lot No.	None
96.LIH	Unavailable	No	Change Lot No.	None
9.GGT	Available	No	Change Lot No.	None
10.LDH	Available	No	Change Lot No.	None
12.ALP	Available	No	Change Lot No.	None
13.AMY	Available	No	Change Lot No.	None
14.ALT	Available	No	Change Lot No.	None
16.CK	Available	No	Change Lot No.	None
20.GLU	Available	No	Change Lot No.	None
21.ALB	Unavailable	No	Change Lot No.	None
22.CA	Unavailable	No	Change Lot No.	None
23.PHOS	Unavailable	No	Change Lot No.	None

Table 2.30 ACAL Tab Description

Item	Contents	Input Notes
Group	Group 1, 2, or 3	Select 1 , 2 , or 3 to program automatic STAT calibration for the Group.
Type	Serum, Urine, Other-1, Other-2, or Whole Blood	
Test Name	Test Name	Displays the test names assigned to Group.
Available/Unavailable	Available or Unavailable	Displays Available if the Position tab lists all of the necessary calibrators.
Auto ACAL/RB	Yes or No	Yes: The system performs automatic STAT calibration according to the execution type. No: The system does not perform automatic STAT calibration.
RB Execution Type	Change Bottle No.	The system performs reagent blank when it switches to the second sequenced reagent bottle because the first sequenced reagent bottle becomes empty during sample analysis. Each sequenced reagent bottle owns a unique bottle number. Bottles have the same reagent lot number.
	Change Lot No.	The system performs reagent blank when it switches to a reagent bottle with a new lot number during analysis because all sequenced reagent bottles with the same lot number become empty during sample analysis.

Table 2.30 ACAL Tab Description (Continued)

Item	Contents	Input Notes
ACAL Execution Type	Change Bottle No.	The system calibrates when it switches to the second sequenced reagent bottle because the first sequenced reagent bottle becomes empty during sample analysis. Each sequenced reagent bottle owns a unique bottle number. All reagent bottles have the same reagent lot number.
	Change Lot No.	The system calibrates when it switches to a reagent bottle with a new lot number during analysis because all sequenced reagent bottles with the same lot number become empty during sample analysis.
	None	The system does not calibrate.

 **Note**

Automatic STAT calibration occurs during sample analysis. You can use advanced calibration by bottle number or lot number to calibrate before QC and sample analysis. Refer to [Calibration Setup: General Tab](#).

Auto ACAL/QC Setup: QC Tab

You can program the automatic STAT QC in the QC tab (**CONFIG. > Auto ACAL/QC Setup > QC**) when you select the STAT Test Order for QC to Cup Pos. For information on programming STAT table positions, refer to [STAT Table Setup](#).

To make automatic STAT QC available, select **Test** or **Sample** in **Cyclic Type**, or **Yes** in **Execute after Calibration**.

Automatic STAT QC occurs during sample analysis after calibration, or a specified number of samples or tests have processed and the STAT table contains the necessary controls.

When you program automatic STAT QC, the amber STAT TABLE ROTATION LED continuously blinks slowly during analysis.

If you do not require cyclic automatic STAT QC, program **None** for all items in **Cyclic Type**.

If you do not require automatic STAT QC after calibration, program **No** for **Execute after Calibration**.

To perform Quick STAT operation, program **None** for all items in **Cyclic Type** and **No** for **Execute after Calibration**.

Select **CONFIG. > Auto ACAL/QC Setup > QC**.

Figure 2.35 Auto ACAL/QC Setup: QC Tab

Table 2.31 QC Tab Description

Item	Contents	Input Notes
Group	Group 1, 2, or 3	Select 1 , 2 , or 3 to program automatic STAT QC for the Group.
Type	Serum, Urine, Other-1, Other-2, or Whole Blood	
Test Name	Test name	Displays the test names assigned to Group .
Available/Unavailable	Available or Unavailable	Displays Available if the Position tab lists all of the necessary controls.
Cyclic Type	None	The system does not perform QC analysis automatically from the STAT table.
	Test	The system performs QC automatically from the STAT table after analysis of the programmed number of tests (displayed in Count).
	Sample	The system performs QC automatically from the STAT table after analysis of the programmed number of samples (displayed in Count).
Count	1 to 999	The test or sample number interval before the system performs QC automatically from the STAT table.
Execute after Calibration	Yes or No	Select Yes to perform QC automatically from the STAT table after reagent blank or calibration.

Misc. Menu

Checked Tests Screen

Obtain a value with optional checked tests using multiple tests and confirm that this value lies within a pre-programmed range. If the result is out of range, the system adds a T flag to the result.

For each sample type, you can program a maximum of 20 checked tests.

Program the calculations for the tests to be checked.

Select **CONFIG. > Checked Tests**.

Figure 2.36 Misc.: Checked Tests Screen

Table 2.32 Checked Tests Screen Description

Item	Contents	Input Notes
Checked Tests Name	Checked test number (1 to 20)	Select the number to program.
Type	Serum, Urine, Other-1, or Other-2	
Check Name box	Selected or Cleared	Select if the checked test is programmed. Keep cleared if the checked test is not used. The system clears all programmed contents when you clear the box.
Check Name field	8 or less characters	Enter the checked test name.
Test Name: A, B, C, D, and E	Test name	

Table 2.32 Checked Tests Screen Description (Continued)

Item	Contents	Input Notes
Constant: a, b, c, and d	Value or Patient Info.-1 to Patient Info.-6	If you select Value , enter a numerical value (maximum of 7 digits) in Value . If you select Patient Info.-1 to Patient Info.-6 , the system uses a value entered in patient demographics in the order for the constant.
Formula	Check calculation formula	Enter the formula with the characters +, -, *, /, (,), A, B, C, D, E, a, b, c, d Enter a maximum of 20 characters.
Check Range	Low and high limit for the check range	If the check exceeds the range, generates a T flag.
Set Decimal Places [F5]	Displays the Set Decimal Places dialog, where you select 0 to 4	Select the number of decimal places for Check Range .

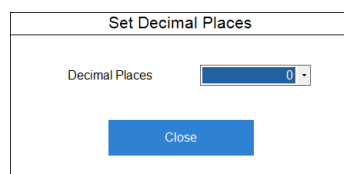
Figure 2.37 Set Decimal Places Dialog

Contamination Parameters Screen

Although the system has sufficient washing capability, cross contamination can occur in readily affected samples or in analysis tests with high sensitivity. You can program extra washing conditions and avoidance parameters to prevent such contamination.



Caution

When you program contamination prevention conditions, the analysis processing speed can decrease. Consult the reagent *Instructions for Use* or the reagent manufacturer.

Contamination Prevention Tab

Program reagent, mix-bar, and cuvette contamination avoidance conditions for readily affected items.



Caution

When you change contamination prevention conditions, perform W2 with the cleaning solutions to prevent the cuvette contamination. The required cleaning solutions depend on what you programmed for cuvette before.

Parameters

Misc. Menu

- If you programmed Yes (CLN-1) for cuvette before change the condition, W2 with CLN-1 is needed.
- If you programmed Yes (CLN-2) for cuvette before change the condition, W2 with CLN-2 is needed.
- If you programmed both of Yes (CLN-1) and Yes (CLN-2) for cuvette before change the condition, both of W2 with CLN-1 and W2 with CLN-2 are needed.
- If you did not program neither Yes (CLN-1) nor Yes (CLN-2) for cuvette before change the condition, W2 is not needed.

Select **CONFIG.** > **Contamination Parameters** > **Contamination Prevention.**

Figure 2.38 Contamination Parameters: Contamination Prevention Tab

Table 2.33 Contamination Prevention Tab Description

Item	Contents	Description
Preceding Test Name	Test name	<p>Select the test and type to perform extra washing before the test analysis. You can also select the cleaning solution (CLN-1, CLN-2), or All for the preceding test.</p> <div style="border: 1px solid black; padding: 5px; margin: 10px 0;"> <p> Note</p> <p>User cannot select the following combinations of settings.</p> <ul style="list-style-type: none"> • Preceding Test is All and Following Test is DENAT. • Preceding Test is DENAT and Following Test is All. </div>
Following Test Name	Test name	Select the test that the preceding test affects, or select All .

Table 2.33 Contamination Prevention Tab Description (Continued)

Item	Contents	Description
Reagent Probe Cleaner Kind	Water, CLN-1 or CLN-2	<p>The system cleans the reagent probe with water, cleaning solution 1, or cleaning solution 2. Place the required cleaning solution on the analyzer.</p> <p>The CLN-1 positions are 62. CLN-1 and 49. CLN-1, and the CLN-2 positions are 63. CLN-2 and 50. CLN-2 next to the refrigerators.</p> <p>There is an option to place CLN-1 into the refrigerators. For more detailed information, refer to Assign Reagent Probe Cleaning Solution-1 Positions in the Refrigerators.</p>
Wash Count	0 to 5	Enter the number of times that the system washes the reagent probe in water or cleaning solution.
Water Cleaning Effective	Yes or No	<p>Yes: The normal rinsing of the reagent probe with deionized water between tests has the same cleaning effect as the programmed contamination avoidance cleaning. If you select 5 for Wash Count for cleaning solution 1, and you run 5 or more tests between the two affected tests, the system does not perform the additional cleaning with cleaning solution 1.</p> <p>No: Cleaning 5 times with cleaning solution 1 always occurs before the affected test, even if you run 5 or more tests between the two affected tests.</p>
Mixer	Yes or No	<p>Yes: The system does not use the mix bar for the following test immediately after the preceding test.</p> <p>No: The system uses the mix bar for processing of the following test immediately after the preceding test.</p>
Cuvette	Yes, Yes (CLN-1), Yes (CLN-2) or No	<p>Yes: The system does not use the cuvette or uses it for a test other than the following test after the preceding test.</p> <p>Yes (CLN-1) or Yes (CLN-2): The system washes the cuvette with cleaning solution 1 or cleaning solution 2 after the preceding test or uses it for a test other than the following test after the preceding test.</p> <p>No: The system can use the cuvette for processing the following test.</p>

This example shows the difference between selecting **Yes** and selecting **No** for **Water Cleaning Effective**.

Other settings:

- Preceding Test Name: A
- Following Test Name: B

Parameters

Misc. Menu

- Reagent Probe Cleaner Kind: CLN-1 or CLN-2
- Wash Count: 5

With these settings, the test sequences of the two samples that require seven tests (A, B, C, D, E, F and G) differ. In this sequence, w is a cycle of cleaner washing.

- **Yes:** First sample: B, A, C, D, E, F, G Second sample: B, A, C, D, E, F, G
- **No:** First sample: B, A, C, D, E, F, G Second sample: A, C, D, E, F, G, w, w, w, w, B

Assign Reagent Probe Cleaning Solution-1 Positions in the Refrigerators

When you select the reagent probe cleaning solution-1 position option in the refrigerator, assign the reagent probe cleaning solution-1 positions in the refrigerators. You can assign up to 5 CLN-1 bottles. After performing a reagent check, the system assigns a 1 to 5 bottle sequence determined by the number of bottles you assign. Bottle sequence 1 has the least volume and bottle sequence 5 has the most volume. When multiple CLN-1 bottles are in use, the system uses bottle sequence 1 until the volume is insufficient. The system then automatically switches to bottle sequence 2. An event message about the bottle switch displays in the event display area.

Caution

When you select a position option, the designated 62.CLN-1 and 50.CLN-1 become unusable. A minimum of one bottle of CLN-1 must always be assigned to a fixed position in the R1 and R2 refrigerators before you perform the reagent check. If a minimum of one CLN-1 bottle is not assigned, the reagent check cannot be completed. The reagent status remains Unchecked in red, and you cannot start analysis or routine operations.

Caution

Use only an alkaline cleaning solution for CLN-1. Acidic cleaning solutions have the potential of affecting other reagents in the refrigerators or the refrigerator components.

1 Select **Reagent > Reagent Management > Details**.

The system displays the Reagent Management: Details tab. The system indicates assigned (fixed) positions with an asterisk highlighted in blue in the column to the left of the Pos. column.

Figure 2.39 Reagent Management: Details Tab

<< Reagent > Reagent Management

Reagent Management | Reagent Inventory | Reagent Consumption | STAT (Calibration) | Rack (Calibration)

Main | Details | ISE

Inaccessible | Unchecked | No Reagent | R1 Status | R2 Status | Type: Serum | Reagent Display: Test | Content: (All)

Pos.	Test Name [1]	R1/R2	Number of Tests	Onboard Remaining	Expiration	Lot No.	Bottle No. (SN)	Seq.	RB Stability Remaining	Cal Stability Remaining	Comment
R1-25	A1c	R1(R1-1)			12/01/2099	2017	B240				
R2-25	A1c	R2(R2-1)			12/01/2099	2017	B240				
* R1-1	CLN-1		235								
* R2-1	CLN-1		235								
* R1-63	CLN-2										
* R2-50	CLN-2										
R1-23	DENAT	R1(R1-1)			12/01/2099	2017	B240				
* R1-64	DET-1										
* R1-65	DET-2										
* R1-61	DIL										
R1-24	T-Hb	R1(R1-1)			12/01/2099	2017	B240				
R1-18	Test-2	R1(R1-1)	2342		12/01/2099	2017	B240				R2(R2-1) Unset
R1-17	Test-4	R1(R1-1)	2342		12/01/2099	2018	1220				No Reagent (Cmn1,R1)
R2-17	Test-4	R2(R2-1)	720		12/01/2099	2018	1220				No Reagent (Cmn1,R1)

Initialize Onboard Stability | ID Edit | Previous Setting

Edit (F1) | Load (F2) | Reagent Check (F5) | Reagent History (F6) | List Display (F7) | Print (F8)

- In **Reagent Display**, select **Position**.
- In **Content**, select **R1** to assign a position in the R1 refrigerator.
- Select an open position to assign to the reagent probe cleaning solution-1.
- Select **Edit** [F1].
The system displays the Edit dialog for the selected position.

Figure 2.40 Edit Dialog (Fixed Reagent)

Pos. R1 2

Reagent ID
 Fixed Reagent

Test Name: CLN-1

Type: -

Lot No.:

Bottle No. (SN):

Bottle Size: 60mL

Bottles other than CLN-1 can not be selected because reagent check was not performed.

OK | Cancel

- Select **Fixed Reagent**.
 - In **Test Name**, select **CLN-1**.

- b. In **Bottle Size**, select **60 mL**.

**Note**

The **Type**, **Lot No.**, and **Bottle No. (SN)** fields become unusable. You cannot select them.

-
- 7** If you assign multiple reagent probe cleaning solution-1 positions, select another position by selecting the forward or back button. Then repeat Step 6.
-
- 8** Select **OK**.
The system closes the Edit dialog.
-
- 9** Confirm that the system indicates assigned (fixed) positions with an asterisk in the column to the left of the Pos. column.
-
- 10** In **Content**, select **R2** to assign a position in the R2 refrigerator.
-
- 11** Select an open position to assign the reagent probe cleaning solution-1.
-
- 12** Select **Edit** [F1].
The system displays the Edit dialog for the selected position.

Figure 2.41 Edit Dialog (Fixed Reagent)

Pos. R2 1

Reagent ID
 Fixed Reagent

Test Name CLN-1

Type

Lot No.

Bottle No. (SN)

Bottle Size 60mL

Bottles other than CLN-1 can not be selected because reagent check was not performed.

OK Cancel

-
- 13** Select **Fixed Reagent**.
- a. In **Test Name**, select **CLN-1**.
- b. In **Bottle Size**, select **60 mL**.

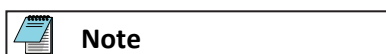
**Note**

The **Type**, **Lot No.**, and **Bottle No. (SN)** fields become unusable. You cannot select them.

14 If you assign multiple reagent probe cleaning solution-1 positions, select another position by selecting the forward or back button. Then repeat step 13.

15 Select **OK**.
The system closes the Edit dialog.

16 Confirm that the system indicates assigned (fixed) positions with an asterisk in the column to the left of the Pos. column.

Carry-over Prevention (Type Changes) Tab

Program extra cleaning of the sample probe between different sample types.

Select **CONFIG. > Contamination Parameters > Carry-over Prevention (Type Changes)**.

Contact Beckman Coulter for detailed information about contamination parameters.

Figure 2.42 Contamination Parameters: Carry-over Prevention (Type Changes) Tab

Checked Tests			Contamination Parameters			Data Check Parameters			
Contamination Prevention			Carry-Over Prevention (Type Changes)			Carry-Over Prevention (Test)			
No.	Combination	Detergent-1	Wash Count Detergent-2	Water	No.	Combination	Detergent-1	Wash Count Detergent-2	Water
1	Serum to Serum	0	0	0	14	Other-1 to Other-2	0	0	0
2	Serum to Urine	0	0	0	15	Other-1 to Whole Blood	0	0	0
3	Serum to Other-1	0	0	0	16	Other-2 to Serum	0	0	0
4	Serum to Other-2	0	0	0	17	Other-2 to Urine	0	0	0
5	Serum to Whole Blood	0	0	0	18	Other-2 to Other-1	0	0	0
6	Urine to Serum	0	0	0	19	Other-2 to Other-2	0	0	0
7	Urine to Urine	0	0	0	20	Other-2 to Whole Blood	0	0	0
8	Urine to Other-1	0	0	0	21	Whole Blood to Serum	0	0	0
9	Urine to Other-2	0	0	0	22	Whole Blood to Urine	0	0	0
10	Urine to Whole Blood	0	0	0	23	Whole Blood to Other-1	0	0	0
11	Other-1 to Serum	0	0	0	24	Whole Blood to Other-2	0	0	0
12	Other-1 to Urine	0	0	0	25	Whole Blood to Whole Blood	0	0	0
13	Other-1 to Other-1	0	0	0					

Table 2.34 Carry-over Prevention (Type Changes) Tab Description

Item	Contents	Input Notes
Wash Count: Detergent-1, Detergent-2, Water	0 to 6	Select the number of times that the system cleans the sample probe with water, detergent 1, and detergent 2 when changing between sample types. Place cleaning solutions detergent 1 and detergent 2 in positions 64. Det-1/W2 and 65. Det-2 on the analyzer by the sample probe.

Carry-over Prevention (Test) Tab

Program extra sample probe washes before or after highly sensitive tests.

Parameters

Misc. Menu

Program the washing count after analysis for tests affecting other tests. Program the washing count before analysis for tests that other tests readily affect.

Contact Beckman Coulter for more information about contamination parameters.

Select **CONFIG. > Contamination Parameters > Carry-over Prevention (Test)**.

Figure 2.43 Contamination Parameters: Carry-over Prevention (Test) Tab

Checked Tests		Contamination Parameters		Data Check Parameters		
Contamination Prevention		Carry-Over Prevention (Type Changes)		Carry-Over Prevention (Test)		
Test Name	Pre-Dispense Wash Count			Post-Dispense Wash Count		
	Detergent-1	Detergent-2	Water	Detergent-1	Detergent-2	Water
1.W1	0	0	0	0	0	0
2.W2	0	0	0	0	0	0
3.W3	0	0	0	0	0	0
4.R-150	0	0	0	0	0	0
5.S-1.0	0	0	0	0	0	0
6.S-1.1	0	0	0	0	0	0
7.S-1.6	0	0	0	0	0	0
8.BUN	0	0	0	0	0	0
9.GGT	0	0	0	0	0	0
10.LDH	0	0	0	0	0	0
11.TP	0	0	0	0	0	0
12.ALP	0	0	0	0	0	0
13.AMY	0	0	0	0	0	0
14.ALT	0	0	0	0	0	0
15.AST	0	0	0	0	0	0
16.CK	0	0	0	0	0	0
17.CREA	0	0	0	0	0	0
18.CO2	0	0	0	0	0	0
19.S1.OP	0	0	0	0	0	0
20.GLU	0	0	0	0	0	0

Buttons: Edit (F1), Print (F8)

Table 2.35 Carry-over Prevention (Test) Tab Description

Item	Contents	Input Notes
Pre-Dispense Wash Count: Detergent-1, Detergent-2, Water	0 to 6	Select the number of times that the system cleans the sample probe with water, detergent 1, and detergent 2 before dispensing the test. Place cleaning solutions detergent 1 and detergent 2 in positions 64. Det-1/W2 and 65. Det-2 on the analyzer by the sample probe.
Post-Dispense Wash Count: Detergent-1, Detergent-2, Water	0 to 6	Select the number of times that the system cleans the sample probe with water, detergent 1, and detergent 2 after dispensing the test. Place cleaning solutions detergent 1 and detergent 2 in positions 64. Det-1/W2 and 65. Det-2 on the analyzer by the sample probe.

Data Check Parameters Screen

Prozone Check Tab

Program check points and decision limits to detect 1 of 4 different abnormal reaction types for Prozone effects in an increasing turbidimetric test. If necessary, the reagent setting sheet provides data check parameters. For more information, contact Beckman Coulter.

1 Select **CONFIG. > Data Check Parameters > Prozone Check**.

Figure 2.44 Data Check Parameter: Prozone Check Tab

Table 2.36 Prozone Check Tab Description

Item	Description
Check Point 1 to Check Point 3	Enter the photometric measuring point for evaluation or the photometric measuring point for start of evaluation.
Check Point Interval	Enter the point interval from the evaluation start point for the check. No input is possible for logic check 1.
Decision Value 1 to Decision Value 3	Enter the OD to use for evaluation.
Limit Point 1, 2	Set evaluation points other than check points. When the low concentration reaction and Prozone draw similar curves, this can be used to cancel low concentration.
Check Pattern (only with Logic Check 1)	<ul style="list-style-type: none"> – Pattern 1: application of both evaluation formulas 1 and 2 – Pattern 2: application of only evaluation formula 1 – Pattern 3: application of only evaluation formula 2 – Pattern 4: neither evaluation formula 1 nor 2 applied

- 2** Select **Edit** [F1].

- 3** Enter a check for one of the data check items 1 through 3, and program the data check tests.
You can check multiple data checks.

- 4** Select **Set Prozone Parameters** [F5].
The Set Prozone Parameters dialog displays.

Parameters

System Condition Menu

Figure 2.45 Set Prozone Parameters Dialog

	OD	Conc.
Point-1		
Point-2		
Point-3		
Point-4		
Point-5		
Point-6		

The system can perform data calculation using a dedicated calibration type. The Set Prozone Parameters dialog displays a polygonal line of the 6-MB formula type, and the concentration value for OD is set.

-
- 5 Select **Close** to close the Set Prozone Parameters dialog.
 - 6 Confirm that the information is correct, and then select **Save** [F1].
-

System Condition Menu

System parameter options affect system operations and software.

Analysis Mode Screen

Program the sample identification mode, auto rerun option, rack number limit for sample type, and alarm sound options in the Analysis Mode screen.

-
- 1 Select **CONFIG. > Analysis Mode**.

Figure 2.46 System Condition: Analysis Mode Screen

<< Configuration Parameters > System Condition > Analysis Mode

Analysis Mode	System Setup	Log on Condition	Comment Masters	User Menu															
<div style="display: flex; justify-content: space-between;"> <div style="width: 30%;"> <p>[Test Order]</p> <p>Routine <input type="text" value="Bar Code"/> -</p> <p>Emergency <input type="text" value="Bar Code"/> -</p> <p><input type="checkbox"/> Sequential Sample ID Read</p> </div> <div style="width: 30%;"> <p>[Auto Rerun]</p> <p>Rack <input type="text" value="Disabled"/> -</p> <p>STAT <input type="text" value="Disabled"/> -</p> <p>[Alarm Sound]</p> <p>Announce <input type="text" value="None"/></p> <p>Caution <input type="text" value="Caution_001"/></p> <p>Warning <input type="text" value="Warning_001"/></p> </div> <div style="width: 30%;"> <p>[S.ID Barcode]</p> <p>Barcode Type <input type="text" value="NW-7"/> -</p> <p>Digits <input type="text" value="0"/></p> <p>Check Mode <input type="text" value="No(No Chk.Chr.)"/> -</p> <p>[Others]</p> <p>Default Type <input type="text" value="Serum"/> -</p> <p>System Action for Reagent Empty <input type="text" value="Alarm Only"/> -</p> </div> </div>																			
<p>[Rack ID Limit]</p> <table border="1" style="width: 100%; border-collapse: collapse;"> <thead> <tr> <th style="width: 20%;"></th> <th style="width: 20%;"></th> <th style="width: 20%;"></th> <th style="width: 20%;"></th> <th style="width: 20%;"></th> </tr> </thead> <tbody> <tr> <td>Routine</td> <td style="text-align: center;">9999</td> <td></td> <td></td> <td></td> </tr> <tr> <td>Emergency</td> <td style="text-align: center;">9999</td> <td></td> <td></td> <td></td> </tr> </tbody> </table>										Routine	9999				Emergency	9999			
Routine	9999																		
Emergency	9999																		
Edit F1		Alarm Sound F5		Print F8															

Table 2.37 Analysis Mode Screen Overview

Option	Description
Test Order	Program the sample identification mode.
Auto Rerun	Program the auto rerun option.
S.ID Bar Code	Program the bar code type to use for sample identification. Select from five types of bar codes. You can use multiple bar code types. If you want to use Multicode, contact Beckman Coulter.
Alarm Sound	Program the alarm sound that the system generates. If you use multiple systems, you can identify each system with a different alarm sound.
Others	Program other system conditions.
Rack ID Limit	Sample kind mixed (default): The system displays 9999. Sample kind sorted (option): Program the rack ID limit for each sample type. The FSE programs this option at the system installation.

2 Select **Edit** [F1].

3 Program the system parameters for each item in the table:

Table 2.38 Analysis Mode Screen Description

Item	Contents	Input Notes
Test Order		
Routine Emergency	Sequential Rack ID Bar Code	<ul style="list-style-type: none"> — Sequential: Performs an item inquiry in the order of sample tube detection. — Rack ID: Performs an item inquiry in the order of rack ID number and sample position in the rack. — Bar Code: Performs an item inquiry according to the bar code ID attached to the sample cups.
Sequential Sample ID Read	Selected or Cleared	Selected: If you select Sequential or Rack ID as the sample identification mode in the Test Order and the sample has a bar code label, the analyzer can read the bar code but does not use this information for the test order. In Sequential and Rack ID modes, the system stores the bar code as the sample ID.
Auto Rerun		
Rack STAT	Disabled Enabled	<ul style="list-style-type: none"> — Disabled: The system generates a rerun list after the first run. The operator determines the samples to rerun, and manually performs the rerun from the white or red racks, or the STAT table. — Enabled: The system automatically performs the rerun using the rerun parameters.
S. ID Bar Code		
Bar Code Type	Select from 7 types	Refer to Sample Bar Code Label Specifications for available bar code types.
Digits	0 to 26 digits	Do not include the check digit. 0 means the number of digits is not specified.

Table 2.38 Analysis Mode Screen Description (Continued)

Item	Contents	Input Notes
Check Mode	No (No Chk. Chr.) No (With Chk. Chr.) Yes	<ul style="list-style-type: none"> — No (No Chk. Chr.): Use bar codes without check characters. The system does not perform a check. — No (With Chk. Chr.): Use bar codes with check characters, but the system does not perform a check. — Yes: Use bar codes with check characters. The system performs the check. <p>For more information, refer to Bar Code Check Methods.</p>
Others		
Default type	Serum, Urine, Other-1, Other-2, or Whole Blood	Select the default sample type to display in Type in all screens.
System Action for Reagent Empty	Event Only or With Pause	<ul style="list-style-type: none"> — Event Only: Analysis continues, except for the empty reagent. — With Pause: Analysis stops for all tests and the system shifts to <i>PAUSE</i> mode.
<ul style="list-style-type: none"> — Select Bar Code analysis if the DxC 700 AU connects to a Laboratory Automation System. — The sample ID does not include the Check Character as a component of it. The system does not display it or store it. — Refer to the Laboratory Automation System manual for available bar code types. — The bar code digits are 0 to 17 if the DxC 700 AU connects to a Laboratory Automation System. — Check Mode is not applicable when the system reads the bar code label on the Laboratory Automation System. 		

Caution

When you enter 0 for the number of digits (no setting) for interleaved 2 of 5, the system can interpret a reading with missing digits as a correct reading. For example, when the system cannot read digits at the edge of the label because of an incorrectly attached label, correct analysis is impossible. The same also applies when interleaved 2 of 5 is included in Multicode.

Caution

Use of sequential mode is not recommended for samples, as positive patient identification cannot be guaranteed. Analysis without a sample ID can cause incorrect patient results.

-
- 4 Select **Alarm Sound** [F5]. The Alarm Sound dialog opens.

Figure 2.47 Alarm Sound Dialog

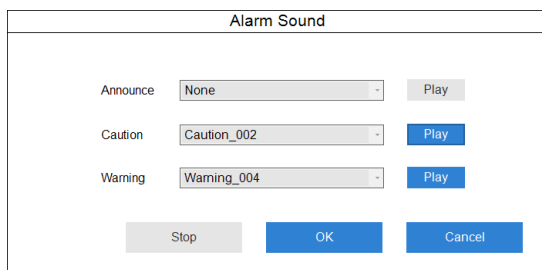

-
- 5 Select the alarm sound to be used for **Announce** (none or seven options), **Caution** (five options), and **Warning** (six options).

If you select **None**, no alarm sounds when the event occurs.



Note

Select **Play** to hear the alarm sound. The alarm sound stops after a specified time or when you select **Stop**, **OK**, or **Cancel**.

-
- 6 Select **OK**.

-
- 7 Confirm that the information is correct, and then select **Save** [F1].
-

Program the Rack ID Limit (Option)

Two options are available to place the samples in the rack:

1. The system analyzes different sample types (serum, urine, Other-1, Other-2, and Whole Blood) in one rack. The system recognizes the sample type with the test order information. This is the default setting.
2. The system analyzes only the same sample type in one rack. The system recognizes the sample type by the rack ID range that you assign to each sample type. This is an optional setting that you can request.

By default, the system analyzes different sample types in one rack, but you can request for a Beckman Coulter Representative to program the system during installation to analyze only the same sample type in one rack. To determine if your system has the default setting, look at the **Rack ID Limit** section of the Analysis Mode screen (**CONFIG. > Analysis Mode**). You cannot edit the values in the **Rack ID Limit** section if it is in default mode. For more information, contact Beckman Coulter.

When you select the second option (the same sample type in one rack), program the rack ID limit for each sample type.

-
- 1 Select **CONFIG. > Analysis Mode**.

Figure 2.48 System Condition: Analysis Mode Screen

<< Configuration Parameters > System Condition > Analysis Mode

Analysis Mode
System Setup
Program the Logon
Comment Master
User Menu

[Test Order]

Routine -

Emergency -

Sequential Sample ID Read

[Auto Rerun]

Rack -

STAT -

[Event Sound]

Announce

Caution

Warning

[S.ID Bar Code]

Bar Code Type -

Digits

Check Mode -

[Others]

Default Type -

System Action for Reagent Empty -

[Rack ID Limit]

	Serum	Urine	Other-1	Other-2	Whole Blood
Routine	5000	9999	0	0	0
Emergency	5000	9999	0	0	0

Edit
F1
Event Sound
F5
Print
F8

2 Select **Edit** [F1].

3 Enter the upper limit value for the rack ID number according to the following input value limitations for **Rack ID Limit**. Refer to [Figure 2.48 System Condition: Analysis Mode Screen](#).

	Serum	Urine	Other-1	Other-2	Whole Blood
Routine	0 to 9999	0 or Serum column + 1 to 9999	0 or Urine column + 1 to 9999	0 or Other-1 column + 1 to 9999	0 or 9999 (non-editable)
Emergency					

The number of digits of the rack ID number is four or five digits according to the programming at installation. The standard is four digits. The explanations apply for four digits.

The corresponding racks are white racks for routine samples, red racks for emergency samples.

The number entered for each sample type is the rack ID upper limit. Starting with the Serum column, then Urine, Other-1, Other-2, and Whole Blood, the number you enter must be higher than any numbers for the previous sample type (up to 9999) or 0.

The system does not process sample types programmed to 0.

The system assigns 0 or 9999 to the last columns automatically.

4 Confirm that the information is correct, and then select **Save** [F1]. If there is a discrepancy, the system highlights the setting with the discrepancy, and the display stays in edit mode.

Parameters

System Condition Menu

System Setup Screen

Program the system language, offline format, sample type name, date format, date and time, other type name, log on password, and auto power on options in the System Setup screen.

Select **CONFIG. > System Setup**.

Figure 2.49 System Setup Screen

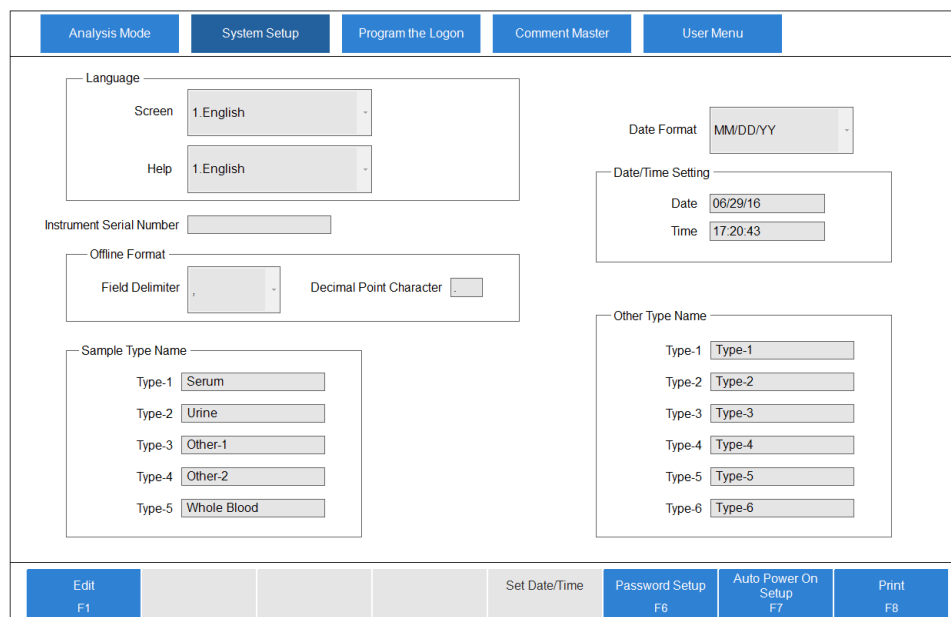

Table 2.40 System Setup Screen Description

Item	Contents	Input Notes
Language		
Screen	Languages	Select the language to display on the screen.
Help	Help languages	Select the system help language.
Instrument Serial Number	A 10-digit number	Display only. The Beckman Coulter System ID
Offline Format		
Field Delimiter	, space tab . : ; - /	Select the delimiter to be added between each item of data.
Decimal Point Character	.	Display only.
Sample Type Name		
Type 1	Serum	Display only.
Type 2	Urine	Display only.
Type 3	Other-1	Enter the operator-defined name.

Table 2.40 System Setup Screen Description (Continued)

Item	Contents	Input Notes
Type 4	Other-2	Enter the operator-defined name.
Type 5	Whole Blood	Display only.
Date Format	Date format	Select the date format.
Date/Time Setting	System date and time	Select Set Date/Time [F5] to change the date and time.
Other Type Name	Type 1 to Type 6	Enter the operator-defined name. Other Type is an additional demographic criteria to classify the patient sample. For more information, refer to Other Type . Used in Specific Range as user demographics criteria. Refer to Range Tab .

Set Date and Time

The system displays the current date and time in the top right corner under the navigation bar. The system updates the current date and time for daylight savings time from regional settings.

- 1 Select **Set Date/Time** [F5].
The system displays the Set Date/Time dialog.

Figure 2.50 Set Date/Time Dialog

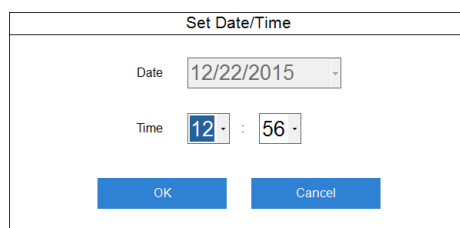

- 2 Set the current date in **Date**.
- 3 Set the current time as a 24-hour display in **Time**.
- 4 Select **OK**.
The system updates the current date and time.

Change the Password for the User Currently Logged On

- 1 Select **Password Setup** [F6].

Figure 2.51 Password Setup Dialog

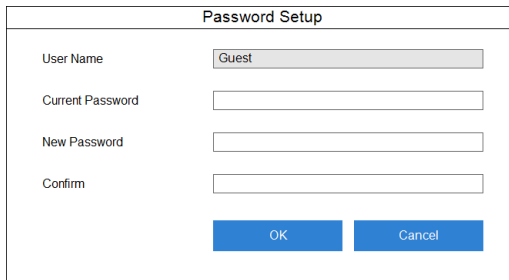

The screenshot shows a 'Password Setup' dialog box with the following fields and buttons:

- User Name: Guest
- Current Password: [Empty]
- New Password: [Empty]
- Confirm: [Empty]
- Buttons: OK, Cancel

2 In **Current Password**, enter the current password.

3 In **New Password**, enter the new password.

You can use up to 20 uppercase and lowercase characters.



Using a password is optional. If you do not enter a password, the user name entered for logon has access to the assigned user level.

4 In **Confirm**, reenter the password entered in step **3**.

5 Select **OK**.

Auto Power On Setup

The lamp requires approximately 20 minutes after pressing **ON** to warm up so that the system can start analysis.

You can program the system to turn on automatically at a specified time of each day of the week.



The Auto Power On option does not open and close the main water valve, so you must leave it open. Follow laboratory standard operating procedures for inspecting the deionized water system and main water valve.

1 Select **Auto Power On Setup** [F7].

Figure 2.52 Auto Power On Setup Dialog

Auto Start Up Time		Auto Preparation	
<input type="checkbox"/> Sunday	00 - : 00 -	<input type="checkbox"/>	
<input type="checkbox"/> Monday	00 - : 00 -	<input type="checkbox"/>	
<input type="checkbox"/> Tuesday	00 - : 00 -	<input type="checkbox"/>	
<input type="checkbox"/> Wednesday	00 - : 00 -	<input type="checkbox"/>	
<input type="checkbox"/> Thursday	00 - : 00 -	<input type="checkbox"/>	
<input type="checkbox"/> Friday	00 - : 00 -	<input type="checkbox"/>	
<input type="checkbox"/> Saturday	00 - : 00 -	<input type="checkbox"/>	

OK Cancel

- 2 Select the desired day to start the Auto Power On function.
- 3 Set the hours and minutes.
- 4 If the Auto Preparation button is enabled, select **Auto Preparation** to perform Auto Preparation.

**Note**

In System Maintenance, Beckman Coulter enables Auto Preparation for each day of the week. The three auto preparation options are:

- W1
- Photocal
- W1 + Photocal

- 5 Repeat steps 2 to 4 for each day to be set.
- 6 Select **OK**.

Program the Logon

Program user names and passwords for the system. Select **LOGOUT** in the navigation button area to log on or out for each operator. The system registers such information.

Each user name belongs to an access level. Assign access levels to menus, submenus, and functions such as Specific Test Parameters or Quality Control.

You can program a maximum of 30 user names with passwords. You can change user names, passwords, and access levels, and delete users. For detailed information, refer to [User Setting Tab](#).

Access Level Tab

You can program access levels from 1 to 10 for each user name. The initial access level is 10, so all users assigned to 1 through 10 have access to menus. The most secure menu access level is 1, as only users assigned as a 1 have access. A user assigned to a 5 for example, has access to menus assigned from 5 to 10. Confirm that a user is programmed to have full access to all menus. For more information, refer to [User Setting Tab](#).

- 1 Select **CONFIG. > Program the Logon > Access Level**.

Figure 2.53 Program the Logon: Access Level Tab

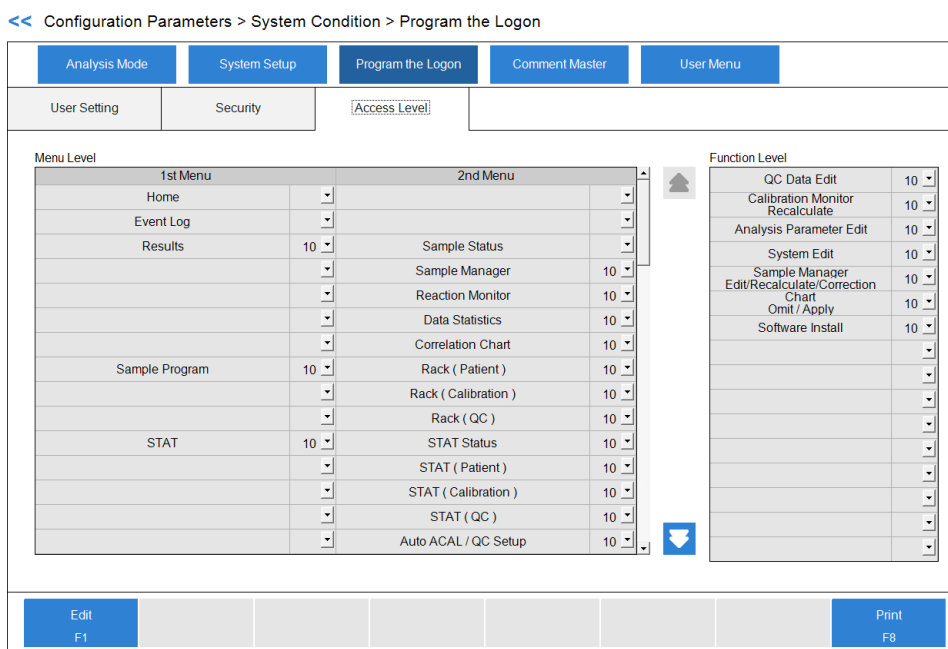

- 2 Select **Edit [F1]**.
- 3 Program the menu level within the range from 1 to 10.

 **Note**

Set the level for the 1st Menu to the same or higher number than the number for the 2nd Menu.

- 4 Repeat step 3 for all of the items for 1st Menu, 2nd Menu, and Function Level.
- 5 Select **Save [F1]**. The Program the Logon dialog opens.

 **Note**

If there is any conflict in access levels between the first Menu and the second Menu, the Logon Condition dialog displays for notification of a programming conflict. Select **Cancel** to resolve the conflict, or **OK** to close the dialog. If you select **OK**, the system assigns the same level from first Menu to second Menu.

6 Select **OK** to save the settings.



You cannot program an item from second Menu with a higher number than an item from first Menu.

User Setting Tab

Program a New User Name and Password

1 Select **CONFIG. > Program the Logon > User Setting.**

Figure 2.54 Program the Logon: User Setting Tab

<< Configuration Parameters > System Condition > Program the Logon

Analysis Mode	System Setup	Program the Logon	Comment Master	User Menu
User Setting		Security	Access Level	
List of Registered Users				
No.	User Name	User Level	Modified Date	Password Time Limit
1	DxC 700 AU	1	02/27/2017	
2				
3				
4				
5				
6				
7				
8				
9				
10				
11				
12				
13				
14				
15				

Edit
F1
Print
F8

2 Select **Edit** [F1].

3 Select an available number in No. (from 1 to 30).

4 Select **Add User** [F2]. The Add User dialog opens.

Figure 2.55 Add User Dialog

The screenshot shows a dialog box titled "Add User". It has four input fields: "User Name", "Password", "Confirm", and "User Level". The "User Level" field is a dropdown menu with "10" selected. At the bottom of the dialog are two buttons: "OK" and "Cancel".

- 5 Enter the **User Name**. Upper and lower case characters can be used for up to 20 characters.
- 6 Enter the password for the new user in **Password**. Upper and lower case characters can be used for up to 20 characters. Use of a password is optional. If a password is not entered, the user name entered for logon has access to the assigned user level.
- 7 For confirmation, reenter the password entered in step 6 in **Confirm**.
- 8 If it is necessary to change the user access level, select 1 to 10 in the User Level column. A smaller number means a higher level of access to menus and functions.
- 9 Select **OK**.
- 10 Repeat steps 3 to 9 for each user.
- 11 Select **Save** [F1]. The Program the Logon dialog opens.
- 12 Select **OK** to save the settings.

 **Note**

Functions and menus that are not accessible mean that the User Level for the user does not allow them to access these items. If you need access to these items, ask an administrator to change the User Level. For more information, refer to [Access Level Tab](#).

Change the User Name Password or User Level

- 1 Select **CONFIG**. > **Program the Logon** > **User Setting**.
- 2 Select **Edit** [F1].
- 3 From **List of Registered Users**, select the user name to be changed.
- 4 Select **Modify** [F3]. The Modify dialog opens.

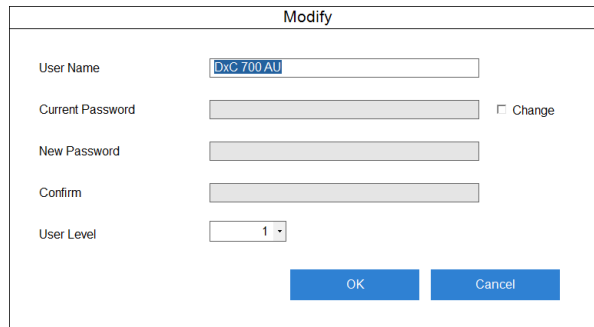
Figure 2.56 Modify Dialog

- 5** Change the **User Name** if necessary.
- 6** Select **Change** to change the password if necessary.
- 7** Enter the **Current Password**.
- 8** Enter the **New Password**.
- 9** For confirmation, reenter the password entered in step **8** in **Confirm**.
- 10** If it is necessary to change the user access level, select 1 to 10 in the User Level column. A smaller number means a higher level of access to menus and functions.
- 11** Select **OK**.
- 12** Select **Save** [F1]. The Program the Logon dialog opens.
- 13** Select **OK** to save the settings.

Delete Users

- 1** Select **CONFIG. > Program the Logon > User Setting**.
- 2** Select **Edit** [F1].
- 3** Select the user name to be deleted and select **Delete** [F4]. The system displays the delete message.
- 4** Select **OK**. The user name is deleted.
- 5** Select **Save** [F1].

Security Tab

Security options include programming a password expiration date, an auto lock of the console, and an auto logon feature.

- 1** Select **CONFIG. > Program the Logon > Security**.

Figure 2.57 Program the Logon: Security Tab

The screenshot shows the 'Program the Logon: Security Tab' interface. It features a top navigation bar with five tabs: 'Analysis Mode', 'System Setup', 'Program the Logon', 'Comment Master', and 'User Menu'. Below this is a sub-navigation bar with three tabs: 'User Setting', 'Security', and 'Access Level'. The main content area is divided into two sections: 'Security Setting' and 'Auto Logon Setting'. 'Security Setting' includes 'Password Expiration Date' with an 'Enable' checkbox and a 'Days' input field, and 'Auto Lock' with an 'Enable' checkbox and a 'Wait time' input field set to '5' minutes. 'Auto Logon Setting' includes 'Auto Logon' with an 'Enable' checkbox and 'Auto Logon User' with a dropdown menu showing 'DxC 700 AU'. At the bottom, there are 'Edit [F1]' and 'Print [F8]' buttons.

- 2 Select **Edit** [F1].
- 3 To set an expiration date for a password, select **Enable** next to **Password Expiration Date**. Enter the number of days that the password is effective before you must change it. You can set a number between 1 and 60 days as an expiration date for the password.
- 4 To auto lock the screen, select **Enable** next to **Auto Lock**. In **Wait time**, select a time from 5 to 60 minutes for the system to wait to activate the auto lock.
- 5 To enable the auto log on function without inputting a user name and password at system startup, select **Enable** next to **Auto Log on**. Select the user name to set up for auto log on in **Auto Log on User**.
- 6 Select **Save** [F1]. The Confirmation dialog opens.
- 7 Select **OK** to save the settings.

 **Note**

The password expiration date is effective for all user names.

 **Note**

You cannot use auto log on when you enable auto lock.

Comment Master Screen

Program a list of standard comments for the system to insert when you select **Comment Master**, as an alternative to reentering the comments manually. You can program up to 220 comments. You can program up to 20 comments for Unit.

- 1 Select **CONFIG. > Comment Masters**.

Figure 2.58 System Condition: Comment Masters Screen

No.	Attribute	Comment
1	Unused	
2	Unused	
3	Information-1	
4	Information-2	
5	Information-3	
6	Information-4	
7	Information-5	
8	Information-6	
9	Others	
10	UnbISO	
11	Unused	
12	Unused	
13	Unused	
14	Unused	
15	Unused	
16	Unused	
17	Unused	
18	Unused	
19	Unused	
20	Unused	

- 2 Select **Edit** [F1].

- 3 In **Attribute**, select the comment attribute.

- For comments number 1 to 220:
 - **Unused**: The comment is not used (no comment).
 - **Information 1 to Information 6**: You can select the comments in demographic fields 1 to 6 in the Demographics tabs (**TEST > Rack (Patient) > Demographics** and **STAT > STAT (Patient) > Demographics**).
 - **Others**: You can select the comment in **Operator Name** in the Change Operator dialog (**HOME > Change Operator** [F2]), or **Comments** in the Demographics tab (**TEST > Rack (Patient) > Demographics** or **STAT > STAT (Patient) > Demographics**), and the Calibration Monitor tab (**MENU > Calibration > Calibration Monitor**).
- For comments number 221 to 240:
 - **Unused**: The comment is not used (no comment).
 - **Unit**: You can select the comment in **Unit** in the Range tab (**CONFIG. > Test Volume and Methods > Range**).

- 4 Enter the comment in **Comment**.

- For comments number 1 to 220:

- **Unused:** You cannot edit the comment. If you change the attribute of an entered comment to **Unused**, the system retains the entered comment.
- **Information 1 to Information 6:** You can enter up to 20 characters.
- **Others:** You can enter up to 50 characters.
- For comments number 221 to 240:
 - **Unused:** You cannot edit the comment. If you change the attribute of an entered comment to **Unused**, the system retains the entered comment.
 - **Unit:** You can enter up to 50 characters.



Note

Program the 1 to 6 patient demographic titles in **<Patient Information>** in the Sample Program Format screen (**CONFIG. > Sample Program Format**). The patient demographic titles display in the Demographics tab (**TEST > Rack (Patient) > Demographics** or **STAT > STAT (Patient) > Demographics**). Refer to [Sample Program Format Screen](#).

-
- 5** Confirm that the information is correct, and then select **Save** [F1].
-

Online Menu

Set the input and output conditions for online connections for this system with a clinical Laboratory Information System. Beckman Coulter typically programs online parameters.

Two methods to connect online:

- RS232C (the default)
- TCP/IP

For changing methods, contact Beckman Coulter. This section describes how to configure each connection.

Program Online Parameters with RS232C Connection

Setup Tab for RS232C

You can select from several communication methods:

- **Realtime:** Test order inquiries and analysis result output are performed during analysis.
- **Batch:** Test order inquiries and analysis result output require operator intervention.
- **None:** No online input or output occurs.

-
- 1** Select **CONFIG. > Online > Setup**.

Figure 2.59 Online: Setup Tab (RS232C)

<< Configuration Parameters > Online

Setup	Protocol	Format Configuration	Online Test No.	
- Test Order Information Receive				
Routine First-Run	None -	STAT First-Run	None -	
Routine Rerun	None -	STAT Rerun	None -	
Emergency First-Run	None -			
Emergency Rerun	None -			
- Analysis Results Transfer Mode				
Routine First-Run	None -	STAT First-Run	None -	Reagent Blank None -
Routine Rerun	None -	STAT Rerun	None -	Calibration None -
Emergency First-Run	None -			QC None -
Emergency Rerun	None -			
<div style="display: flex; justify-content: space-between; align-items: center;"> Edit F1 Print F8 </div>				

**Note**

- **Test Order Information Receive:** Program the test order inquiry mode. Select from three inquiry modes for routine first-run, routine rerun, emergency first-run, emergency rerun, STAT first-run, and STAT rerun.
 - Realtime
 - Batch
 - None (default)
- **Analysis Results Transfer Mode:** Program the output method for analysis results. Select from three output options for routine first-run, routine rerun, emergency first-run, emergency rerun, STAT first-run, STAT rerun, reagent blank, calibration, and QC.
 - Realtime
 - Batch
 - None (default)

If the DxC 700 AU connects to a Laboratory Automation System, you cannot set the output method for routine rerun, emergency first-run, and emergency rerun.

2 Select **Edit** [F1].

3 Select the communication method for each sample kind.

4 Confirm that the information is correct, and then select **Save** [F1].

Protocol Tab for RS232C

Program the online communication protocol.

- 1 Select **CONFIG.** > **Online** > **Protocol**.

Figure 2.60 Online: Protocol Tab (RS232C)

- 2 Select **Edit [F1]**.

- 3 Program the parameters.

Table 2.41 Protocol Tab for RS232C Description

Setting	Values	Initial Value
Upper Protocol		
T.R.I Receive Error Control	<ul style="list-style-type: none"> — Stop: When a communication error occurs, communication stops after the sample with the communication error. — Continue: Even when a communication error occurs, the system executes T.R.I. for the next sample. 	Stop

Table 2.41 Protocol Tab for RS232C Description (Continued)

Setting	Values	Initial Value
Results Transfer Error Control	<ul style="list-style-type: none"> — Stop: When a communication error occurs, communication stops after the sample with the communication error. — Continue: Even when a communication error occurs, the system executes T.R.I. for the next sample. 	Stop
Lower Protocol		
<Character Format>		
Character Length	7 and 8	7
Parity Bit	None, Even, and Odd	None
Stop Bit	1 and 2	1
<Basic Data Format>		
Start Code (1st)	01h:SOH to 1Fh:US	02h:STX
Start Code (2nd)	None, 01h:SOH to 1Fh:US	None
End Code (1st)	01h:SOH to 1Fh:US	03h:ETX
End Code (2nd)	None, 01h:SOH to 1Fh:US	None
Text Length	256, 512, and 1024	1024
Device No.	Unchecked and Checked	Unchecked
Device No. (checked)	00 to 99	00
ETB Control	Unchecked and Checked	Unchecked
<Communication Control>		
Bit/Sec.	4800 and 9600	9600
Class	Class A (No ACK/NACK) Class B (With ACK/NACK)	Class A
Retry	0 to 3	1
BCC Check	Unchecked and Checked	Unchecked
<Time Out [x 100msec.]>		
T1	1 to 99 msec.	20
T2	1 to 99 msec.	15

Table 2.41 Protocol Tab for RS232C Description (Continued)

Setting	Values	Initial Value
T3	1 to 99 msec.	15
T4	1 to 99 msec.	20
T5	1 to 99 msec.	20
T6	1 to 99 msec.	10
T7	1 to 99 msec.	20

- 4** Confirm that the information is correct, and then select **Save** [F1].



Note

Beckman Coulter typically programs online parameters.



Note

Program the protocol after confirmation with the system administrator of the Laboratory Information System. A discrepancy with the settings on the Laboratory Information System might prevent correct communication.

Format Configuration Tab for RS232C

Program the additional information and number of digits for data for online communication.

-
- 1** Select **CONFIG. > Online > Format Configuration.**

Figure 2.61 Online: Format Configuration Tab (RS232C)

Setup	Protocol	Format Configuration	Online Test No.
<div style="display: flex; justify-content: space-between;"> <div style="width: 45%;"> <p>Used/Unused</p> <ul style="list-style-type: none"> <input checked="" type="checkbox"/> Rack ID/Cup Pos. <input checked="" type="checkbox"/> Type <input type="checkbox"/> Dilution Info. <input type="checkbox"/> Run Date/Time <input type="checkbox"/> Reagent Info. <input type="checkbox"/> R1-2 Use <input checked="" type="checkbox"/> ISE Info. <input checked="" type="checkbox"/> Zero Suppress </div> <div style="width: 45%;"> <p>Others</p> <ul style="list-style-type: none"> Rack ID Digit <input type="text" value="4"/> Digits Online Test No. Digit <input type="text" value="3"/> Digits Result Digit <input type="text" value="6"/> Digits No. of Data Flags <input type="text" value="2"/> Digits Cal. No./Control No. Digit <input type="text" value="3"/> Digits </div> </div>			
<input type="button" value="Edit"/> F1		<input type="button" value="Print"/> F8	

— **Used/Unused:** Selected items to be added to online communication messages.

— **Others:**

- **Rack ID Digit:** Four or five digits
- **Online Test No. Digit:** Two or three digits for the test number programmed in the Online Test No. tab (**CONFIG. > Online > Online Test No.**).
- **Result Digit:** Six or nine digits for the data to be added to the message.
- **No. of Flags:** Two or four flags to be added to the message.
- **Cal. No./Control No. Digit:** Two or three digits



Caution

After confirmation, the system administrator must set the data format on the Laboratory Information System. A discrepancy with the settings on the Laboratory Information System might prevent correct communication.

- 2** Select **Edit** [F1].
- 3** Select the items to be used for online communication in **Used/Unused**.
- 4** Select the digits for each item in **Others**.
- 5** Confirm the information, and then select **Save** [F1].

Online Test No. Tab for RS232C

Assign each test name to an online test number for online communication.

 **Note**

Total and direct bilirubin are programmed as sample blank tests. For more information, refer to [Test Name Parameters Screen](#).

For a blank test in sample blank tests, you cannot program an online test number because the system uses the blank test result only for the calculation and is not a reported result.

- 1 Select **CONFIG. > Online > Online Test No.**

Figure 2.62 Online: Online Test No. Tab (RS232C)

Setup	Protocol	Format Configuration	Online Test No.						
Test Name	Online Test No.	Test Name	Online Test No.	Test Name	Online Test No.	Test Name	Online Test No.	Test Name	Online Test No.
1 ALB	001	2 ALP	002	3 ALT	003	4 AMY	004	5 AST	005
6 CO2	006	7 DBILC	007	8 DBB	008	9 TBILC	009	10 TBB	010
11 CA	011	12	012	13	013	14	014	15	015
16	016	17	017	18	018	19	019	20	020
21 IRON	021	22	022	23	023	24	024	25	025
26	026	27	027	28	028	29	029	30	030
31	031	32	032	33	033	34	034	35	035
36	036	37	037	38	038	39	039	40	040
41	041	42 UIBCr	042	43	043	44	044	45	045
46	046	47	047	48	048	49	049	50	050
51	051	52	052	53	053	54	054	55	055
56	056	57	057	58	058	59	059	60	060
61	061	62	062	63	063	64	064	65	065
66	066	67	067	68	068	69	069	70	070
71	071	72	072	73	073	74	074	75	075
76	076	77	077	78	078	79	079	80	080
81	081	82	082	83	083	84	084	85	085
86	086	87	087	88	088	89 %SATr	089	90	090
91	091	92	092	93	093	94	094	95	095
96 LIH	096	97 Na	097	98 K	098	99 Cl	099	100 HbA1c	
101 T-Hb		102 A1c	103		103	104	104	105	105
106	106	107	107	108	108	109	109	110	110
111	111	112	112	113	113	114	114	115	115
116	116	117	117	118	118	119	119	120	120

Edit F1
Print F8

- 2 Select **Edit [F1]**.
- 3 Select the test name to be programmed.
- 4 Enter the number in **Online Test No.** The combination of the online test number and test must agree with what is in the Laboratory Information System. Set the number as a blank when you do not require online communication.

 **Note**

A discrepancy with the settings on the Laboratory Information System might prevent correct communication.

- 5 Repeat steps 3 and 4 for each test to be programmed.
- 6 Confirm that the information is correct, and then select **Save [F1]**.

- 7 If you entered duplicate numbers, the Parameter Error(s) dialog displays. Select **Cancel** and make corrections.

Program Online Parameters with TCP/IP Connection

Setup Tab for TCP/IP

You can select from four communication methods:

- Realtime: Test order inquiries and analysis result output are performed during analysis.
- LIS Direction: The Laboratory Information System sends test order information to the DxC 700 AU, and the DxC 700 AU saves the information (without an inquiry process from the DxC 700 AU) during analysis and other modes.
- Batch: Test order inquiries and analysis result output require operator intervention.
- None: No online input or output occurs.

- 1 Select **CONFIG. > Online > Setup.**

Figure 2.63 Online: Setup Tab (TCP/IP)

<< Configuration Parameters > Online

Setup	Protocol	Format Configuration	Online Test No.	
- Test Order Information Receive				
Routine First-Run	None	STAT First-Run	None	
Routine Rerun	None	STAT Rerun	None	
Emergency First-Run	None			
Emergency Rerun	None			
- Analysis Results Transfer Mode				
Routine First-Run	None	STAT First-Run	None	Reagent Blank: None
Routine Rerun	None	STAT Rerun	None	Calibration: None
Emergency First-Run	None			QC: None
Emergency Rerun	None			
- Other Transfer				
Equipment State	None			
Edit F1				Print F8

- **Test Order Information Receive:** Program the test order inquiry mode. Select from three inquiry modes for routine first-run, routine rerun, emergency first-run, emergency rerun, STAT first-run, and STAT rerun.
 - Realtime
 - LIS Direction
 - None (default)
- **Analysis Results Transfer Mode:** Program the output method for analysis results. Select from three output options for routine first-run, routine rerun, emergency

first-run, emergency rerun, STAT first-run, STAT rerun, reagent blank, calibration, and QC.

- Realtime
- Batch
- None (default)
- **Other Transfer:** Program the system for output to LIS. When the test order is received with LIS Direction, select **Enable** in **Equipment State**.
 - Enable
 - None (default)

2 Select **Edit** [F1].

3 Select the communication method for each sample kind.

4 Confirm the information, and then select **Save** [F1].

Protocol Tab for TCP/IP

Program the online communication protocol.

1 Select **CONFIG. > Online > Protocol**.

Figure 2.64 Online: Protocol Tab (TCP/IP)

<< Configuration Parameters > Online

Setup	Protocol	Format Configuration	Online Test No.
<Editing>			
Upper Protocol			
T.R.I Receive Error Control		Stop	
Results Transfer Error Control		Stop	
Lower Protocol			
-<Basic Data Format->			
Start Code	1st. 02h.STX	2nd. None	<Time Out[x100msec]->
End Code	1st. 03h.ETX	2nd. None	T1 10
			T2 40
			T3 5
			T4 5
<input type="checkbox"/> Device ID			
<input type="checkbox"/> LIS ID			
-<Communication Control->			
Retry		1	
Save F1			

2 Select **Edit** [F1].

3 Program the parameters.

Table 2.42 Protocol Tab for TCP/IP Description

Setting Item	Setting Range	Default
T.R.I Receive Error Control	<ul style="list-style-type: none"> — Stop: When a communication error occurs, communication stops after the sample with the communication error. — Continue: Even when a communication error occurs, the system executes T.R.I. for the next sample. 	Stop
Results Transfer Error Control	<ul style="list-style-type: none"> — Stop: When a communication error occurs, communication stops after the sample with the communication error. — Continue: Even when a communication error occurs, the system executes T.R.I. for the next sample. 	Stop
Start Code (1st)	None, 01h to 1Fh	None
Start Code (2nd)	None, 01h to 1Fh	None
End Code (1st)	None, 01h to 1Fh	None
End Code (2nd)	None, 01h to 1Fh	None
Device ID box	Selected or Cleared	Cleared
Device No.	32 characters	-
LIS ID box	Selected or Cleared	Cleared
LIS ID	32 characters	-
<Time Out [×100msec.]> T1	00 to 99 msec.	50
<Time Out [×100msec.]> T2	00 to 99 msec.	60
<Time Out [×100msec.]> T3	00 to 99 msec.	20
<Time Out [×100msec.]> T4	00 to 99 msec.	50
Retry	0 to 3	3

4 Confirm the information, and then select **Save** [F1].

Format Configuration Tab for TCP/IP

Program the additional information for online communications.

- 1 Select **CONFIG. > Online > Format Configuration.**

Figure 2.65 Online: Format Configuration Tab (TCP/IP)

<< Configuration Parameters > Online

Setup	Protocol	Format Configuration	Online Test No.	
-------	----------	----------------------	-----------------	--

<Editing>

Used/Unused

Sample No.

Dilution Info.

Save
F1



Caution

After confirmation, the system administrator must set the data format on the Laboratory Information System. A discrepancy with the settings on the Laboratory Information System might prevent correct communication.

- 2 Select **Edit [F1]**.
- 3 Select the additional items to be used for online communication in **Used/Unused**.
- 4 Confirm the information, and then select **Save [F1]**.

Online Test No. Tab for TCP/IP

Assign each test name to an online test number for online communication.

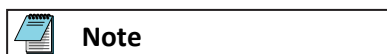

Note

Total and direct bilirubin are programmed as sample blank tests. For more information, refer to [Test Name Parameters Screen](#).

For a blank test in sample blank tests, you cannot program an online test number because the system uses the blank test result only for the calculation and is not a reported result.

1 Select **CONFIG. > Online > Online Test No.**

Figure 2.66 Online: Online Test No. Tab (TCP/IP)

Setup	Protocol	Format Configuration	Online Test No.						
Test Name	Online Test No.	Test Name	Online Test No.	Test Name	Online Test No.	Test Name	Online Test No.	Test Name	Online Test No.
1 ALB	001	2 ALP	002	3 ALT	003	4 AMY	004	5 AST	005
6 CO2	006	7 DBILC	007	8 DBB	008	9 TBILC	009	10 TBB	010
11 CA	011	12	012	13	013	14	014	15	015
16	016	17	017	18	018	19	019	20	020
21 IRON	021	22	022	23	023	24	024	25	025
26	026	27	027	28	028	29	029	30	030
31	031	32	032	33	033	34	034	35	035
36	036	37	037	38	038	39	039	40	040
41	041	42 UIBCr	042	43	043	44	044	45	045
46	046	47	047	48	048	49	049	50	050
51	051	52	052	53	053	54	054	55	055
56	056	57	057	58	058	59	059	60	060
61	061	62	062	63	063	64	064	65	065
66	066	67	067	68	068	69	069	70	070
71	071	72	072	73	073	74	074	75	075
76	076	77	077	78	078	79	079	80	080
81	081	82	082	83	083	84	084	85	085
86	086	87	087	88	088	89 %SATr	089	90	090
91	091	92	092	93	093	94	094	95	095
96 LIH	096	97 Na	097	98 K	098	99 Cl	099	100 HbA1c	
101 T-Hb		102 A1c		103	103	104	104	105	105
106		106	107	108	108	109	109	110	110
111		111	112	113	113	114	114	115	115
116		116	117	118	118	119	119	120	120

2 Select **Edit** [F1].

3 Select the test name to be programmed.

4 Enter the number in **Online Test No.** The combination of the online test number and test must agree with what is in the Laboratory Information System. Set the number as a blank when you do not require online communication.

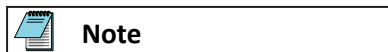

Note

A discrepancy with the settings on the Laboratory Information System might prevent correct communication.

5 Repeat steps **3** and **4** for each test to be programmed.

6 Confirm that the information is correct, and then select **Save** [F1].

7 If you entered duplicate numbers, the Parameter Error(s) dialog displays. Select **Cancel** and make corrections.

Sample Program Format Screen

Program the test order format, including sample ID and demographic information.

Information programmed in the Sample Program Format screen is part of the data communication protocol, and impacts LIS communication.

1 Select CONFIG. > Sample Program Format.

Figure 2.67 Sample Program Format Screen

<< Configuration Parameters > Format > Sample Program Format

2 Program the sample program format for each item in the table.

Table 2.43 Sample Program Format Screen Description

Item	Contents	Input Notes
Sample ID	Selected or Cleared	Select to enable Sample ID in the Test Order tab (TEST > Rack (Patient) > Test Order) or STAT > STAT (Patient) > Test Order).

Table 2.43 Sample Program Format Screen Description (Continued)

Item	Contents	Input Notes
Digits	4 to 26	Affects how many digits you can enter for the Sample ID in the Test Order tab (TEST > Rack (Patient) > Test Order) or STAT > STAT (Patient) > Test Order). Affects the sample ID field length for the Laboratory Information System online records. Program the number of sample ID digits and bar code parameters in the Analysis Mode screen (CONFIG. > Analysis Mode). Program the number of digits to be greater than or equal to the digits in the Analysis Mode screen.
Sex	Selected or Cleared	Select Sex to enable sex as a demographic in the Demographics tab (TEST > Rack (Patient) > Demographics or STAT > STAT (Patient) > Demographics), or receive the information from the LIS. Affects the Laboratory Information System online records.
Age	Selected or Cleared	Select Age to enable age as a demographic in the Demographics tab (TEST > Rack (Patient) > Demographics or STAT > STAT (Patient) > Demographics), or receive the information from the LIS. Affects the Laboratory Information System online records.
Other Type	Selected or Cleared	Select Other Type to enable Other Type as a demographic in the Demographics tab (TEST > Rack (Patient) > Demographics or STAT > STAT (Patient) > Demographics), or receive the information from the LIS. Affects the Laboratory Information System online records. For more information, refer to Other Type .

Parameters

Sample Program Format Screen

Table 2.43 Sample Program Format Screen Description (Continued)

Item	Contents	Input Notes
Data Output at Analytical Measuring Range Error	Output Conc. or Suppress Result	<p>If you require the concentration value to be output when the result is out of analytical measuring range, select Output Conc. If you do not want the concentration value to be output when the result is out of analytical measuring range, select Suppress Result.</p> <div data-bbox="906 651 1294 703" style="border: 1px solid black; padding: 5px;">  Note </div> <p>If you select No for Analytical Measuring Range Error Rerun in the Rerun Test Parameters screen (CONFIG. > Rerun Test Parameters), the system outputs the concentration value, even if you select Suppress Result.</p>
Patient Information		<p>You can program a maximum of 6 patient demographics for entry in the Demographics tab (TEST > Rack (Patient) > Demographics or STAT > STAT (Patient) > Demographics). Affects Laboratory Information System online records.</p>
Enable	Selected or Cleared	<p>Select to enable programming for patient demographics numbers 1 to 6.</p>
Attribute	Character or Numeric	<p>Program if you require letters or numbers for entry in the Demographics tab (TEST > Rack (Patient) > Demographics or STAT > STAT (Patient) > Demographics) for patient information. Select Character to enter letters. Select Numeric to enter numbers for calculated tests and checked tests.</p>
Title	A title name	<p>Enter a maximum of 20 characters that display as the title for the patient information in the Demographics tab (TEST > Rack (Patient) > Demographics or STAT > STAT (Patient) > Demographics).</p>
Digits	1 to 20	<p>Affects how many digits can be displayed in Patient Information in the Demographics tab (TEST > Rack (Patient) > Demographics or STAT > STAT (Patient) > Demographics).</p>

Table 2.43 Sample Program Format Screen Description (Continued)

Item	Contents	Input Notes
Comment Master Selection	Information-1 to Information-6	Program the attribute in the Comment Master screen (CONFIG. > Comment Master) with Information-1 to Information-6 . You can then select the master comment in the Demographics tab (TEST > Rack (Patient) > Demographics or STAT > STAT (Patient) > Demographics).
Representation-1 and Representation-2	Patient Information No. 1 to Patient Information No. 6	<p>Select from Patient Information No. 1 to Patient Information No. 6 for the text in Title to display in the following screens or tabs:</p> <ul style="list-style-type: none"> — As a column heading in the Sample Status screen (RESULT > Sample Status) — As a column heading in the Sample Manager: Main tab (RESULT > Sample Manager > Main) — As a column heading in the Sample Manager: By Patient Test tab (RESULT > Sample Manager > By Patient Test) — As a field heading in the Sample Manager: By Patient Sample tab (RESULT > Sample Manager > By Patient Sample) — As information in the Cup Information column in the STAT Status screen (STAT > STAT Status)

List Format Screen

You must program the list format to print the test summary from the **Test Order** tab, the result from **Sample Manager > Main** tab, and the realtime printing. The following five list types are available:

1. Table Type
2. Enumeration Type
3. Data List
4. Results (Fix) Type
5. Result (Seq.) Type

[Table 2.44 List Types](#) shows the list types available in each menu.

Parameters

List Format Screen

Table 2.45 Output Settings for Each List Type shows the possible output contents for each list type and the layout available for each list type.

List Types Available in Specific Menus

Table 2.44 List Types

Menu	Table Type	Enumeration Type	Data List	Result (Fix) Type	Result (Seq.) Type
Test Order > Print [F8]	o				
Sample Manager > Main > Print [F8] > Patient	o	o		o	o
Sample Manager > Main > Print [F8] > RB/CAL/QC			o		
List Format > Realtime List [F5]Patient		o		o	o
List Format > Realtime List [F5] > Calibration, RB, QC			o		

Format Parameters for Each List Type

Table 2.45 Output Settings for Each List Type includes possible output settings for each list type.

- : Required output item
- o: Optional item
- x: Item is not available

Table 2.45 Output Settings for Each List Type

	Title	List Type									
		Table Type		Enumeration Type		Data List		Result (Fix) Type		Result (Seq.) Type	
		Title	Data	Title	Data	Title	Data	Title	Data	Title	Data
Basic Condition	List Name	Within 20 single-byte characters									
	Data Format	6/9	6/9	6/9	6/9	6/9	6/9	6/9	6/9	6/9	6/9
	Data Justify	Right/ Left	Right/ Left	Right/ Left	Right/ Left	Right/ Left	Right/ Left	Right/ Left	Right/ Left	Right/ Left	Right/ Left
	Patient	o	o	x	x	x	x	x	x	x	x
	Calibration	x	x	o	o	x	x	x	x	x	x
	RB	x	x	o	o	x	x	x	x	x	x
	QC	x	x	o	o	x	x	x	x	x	x
	Print Direction	Portrait/Landscape									
	Paper Size	A4/Letter/Legal/Tabloid									
	Sheet Number ^{1, 4}	x	x	x	x	1 to 4	1 to 4	1 to 4	1 to 4	1 to 4	1 to 4
	Character in sheet ^{2, 4}	x	x	o	o	o	o	o	o	o	o
	Form Method of Test Name ^{3, 4}	x	x	x	x	o	o	o	o	o	o
	Number of Flags	x	x	1 to 4	1 to 4	1 to 4	1 to 4	1 to 4	1 to 4	1 to 4	1 to 4
	Form Method of Data not analyzed	x	x	x	x	o	o	o	o	o	x

Table 2.45 Output Settings for Each List Type (Continued)

	Title	List Type									
		Table Type		Enumeration Type		Data List		Result (Fix) Type		Result (Seq.) Type	
		Title	Data	Title	Data	Title	Data	Title	Data	Title	Data
	Change Page	x		x		x		o		o	
	Line	x		x		o		o		o	
	Fixed Comment	x		x		o		o		o	
Page Header	Header Width ⁴	1 to 10 lines									
	Device No.	•	•	•	•	•	•	o	o	o	o
	List Name	o	o	o	o	o	o	o	o	o	o
	Page	o	o	o	o	o	o	o	o	o	o
	Index	o	o	o	o	o	o	o	o	o	o
	Group	o	o	o	o	o	o	o	o	o	o
	Print time	o	o	o	o	o	o	o	o	o	o
	Operator	o	o	o	o	o	o	o	o	o	o
	Reporter	o	o	o	o	o	o	o	o	o	o
Sample Information	Sample Width ⁴	1 to 10 lines									
	Sample No.	o	o	o	o	o	o	o	o	o	o
	Rack ID - Cup Pos.	o	o	o	o	o	o	o	o	o	o
	Sample ID	o	o	o	o	o	o	o	o	o	o
	Sex	o	o	o	o	x	x	o	o	o	o
	Age	o	o	o	o	x	x	o	o	o	o
	Month	o	o	o	o	x	x	o	o	o	o
	Other Type	o	o	o	o	x	x	o	o	o	o
	Type	o	o	o	o	o	o	o	o	o	o

Table 2.45 Output Settings for Each List Type (Continued)

	Title	List Type									
		Table Type		Enumeration Type		Data List		Result (Fix) Type		Result (Seq.) Type	
		Title	Data	Title	Data	Title	Data	Title	Data	Title	Data
	Sample Vol.	o	o	o	o	o	o	o	o	o	o
	Sample Dilution Rate	o	o	o	o	x	x	o	o	o	o
	Patient Info. 1 to 6	o	o	o	o	x	x	o	o	o	o
	Patient Comment	x	x	x	x	x	x	o	o	o	o
	Sample Name	x	x	x	x	o	o	x	x	x	x
	Kind No.-Seq. No.	x	x	x	x	o	o	x	x	x	x
	Lot No.	x	x	x	x	o	o	x	x	x	x
	Run Date/Time	o	o	o	o	o	o	o	o	o	o
Test Information		1 to 10 lines									
	Test Name	x	•	x	o	x	•	x	o	x	o
	Test Dilution	x	o	x	o	x	x	x	o	x	o
	Pre-Dilution Rate	x	o	x	o	x	x	x	o	x	o
	Result	x	o	x	•	x	•	x	•	x	•
	Flags	x	o	x	o	x	o	x	o	x	o
	R. Bottle Info.	x	o	x	o	x	o	x	o	x	o
	ISE Info.	x	o	x	o	x	o	x	o	x	o
	Unit	x	x	x	x	x	x	x	o	x	o
	Reference Interval	x	x	x	x	x	o	x	o	x	o
	Output	o	o	o	o	x	x	x	x	x	x
Tail Information	Total Tests	o		o		x		x		x	
	Total Samples	o		o		x		x		x	

Table 2.45 Output Settings for Each List Type (Continued)

	Title	List Type									
		Table Type		Enumeration Type		Data List		Result (Fix) Type		Result (Seq.) Type	
		Title	Data	Title	Data	Title	Data	Title	Data	Title	Data
	Reagent Consumption	o		o		x		x		x	
	Tail name	o		o		x		x		x	

- Set the number of samples to print on one form sheet.
- The maximum number of characters per line differs according to the print direction, the paper size, and the sheet number.
 - Portrait, A4, 1 sheet: 136 characters per line
 - Landscape, A4, 1 sheet: 168 characters per line
 - Portrait, A3, 1 sheet: 192 characters per line
 - Landscape, A3, 1 sheet: 240 characters per line
 - Portrait, Letter, 1 sheet: 136 characters per line
 - Landscape, Letter, 1 sheet: 156 characters per line
 - Portrait, Tabloid, 1 sheet: 180 characters per line
 - Landscape, Tabloid, 1 sheet: 240 characters per line
 - Portrait, Legal, 1 sheet: 136 characters per line
 - Landscape, Legal, 1 sheet: 192 characters per line
 - For two sheets or more, the number of lines in this list is the number of lines divided by the sheet number.
- Program whether to use the abbreviated name or long name as the test name.
- The system cancels the layout setting when the print direction, the paper size, sheet number, character in sheet, header width, or sample width changes. Program the layout again.

Layout Setting Parameters

Table 2.46 Layout Setting Parameters

	Menu	Table Type	Enumeration Type	Data List	Result (Fix) Type	Result (Seq.) Type
Layout	Page Header	o	o	o	o	o
	Sample Information	o	o	o	o	o
	Test Information	x	x	x	o	o

For the Result (Fix) type, the system formats the test information print position to a specific column and line for each test.

For the Result (Seq.) type, the start position for printing test information is set. The specific tests ordered on a sample start printing in consecutive lines at the formatted start print position.

For types other than Result (Fix) and Result (Seq.), you cannot set the test information print position.

Copy Format Parameters

The following eight templates are available from **Manufacturer made**:

1. Patient Data List (Result (Seq.) Type)
2. Patient Data List 2 (Result (Seq.) Type)
3. Patient Report (Result (Seq.) Type)
4. Patient Report 2 (Result (Seq.) Type)
5. Calibration Report (Data List)
6. QC Report (Data List)
7. RB/CAL/QC Data List (Data List)
8. Test Summary (Table Type)
9. (Empty)
10. (Empty)
11. (Empty)
12. (Empty)
13. (Empty)
14. (Empty)
15. (Empty)

You can use these templates by copying them to **User made**, or you can copy the format parameters from one of list formats in **User made**.

-
- 1 Select **CONFIG. > List Format > Basic Condition**.

 - 2 Select **Edit** [F1].

 - 3 Select an available list number (location to copy another list) in **List Name**.

 - 4 Select **Copy** [F7]
The Copy dialog opens.

 - 5 Select **Manufacturer made** or **User made**.



If you want to clear the settings of the list number, in **Copy from**, select the empty list number (9 through 15) from **Manufacturer made** and copy it into the list number that you want to delete. Rename the list with a blank space in **List Name**.

-
- 6 Select the list to copy in **Copy from**.

 - 7 Confirm the list number in **Copy to** is the list number you selected in step 3. Select another number if necessary.

 - 8 Select **OK**.
The system copies the list parameters.

9 Enter a list name for the copied list in **List Name**.

10 Select **Save** [F1].

Program List Formats

Program the format parameters for reports and lists. Five templates that are copied from **Manufacturer made** appear in No. 1 to No. 5 in **List Name** by default.

1 Select **CONFIG. > List Format > Basic Condition**.

Figure 2.68 List Format: Basic Condition Tab

<< Configuration Parameters > Format > List Format

Sample Program Format		List Format	
Basic Condition	Print Information	Printed Test	Layout
List Name	1.Patient Data List	List Type	Result(Seq.) Type
List Name	Patient Data List	Print Direction	Portrait
Data Format	9	Paper Size	A4
Data Justify	Right	Sheet Number	1
Data Separator	<input type="checkbox"/> Patient <input type="checkbox"/> Calibration <input type="checkbox"/> RB <input type="checkbox"/> QC	Character in Sheet	109
		Form Method of Test Name	Test Name
		Number of Flags	4
		Form Method of Data not analyzed	
		<input type="checkbox"/> Change Page	
		<input type="checkbox"/> Line	
		<input type="checkbox"/> Fixed Comment	
	<input type="checkbox"/> Output File		
Edit F1		List Type Selection	Realtime List F5
			Report Setup F6
			Copy
			Print F8

2 Select **Edit** [F1].

3 Select the list number to be formatted in **List Name**.

4 In **List Name**, enter a list name with a maximum of 20 characters.

5 Select **List Type Selection** [F4] to change the list type. The List Type Selection dialog opens.

6 Select the list type in **List Type**.

7 Select **OK**.

8 Select or enter settings for the list format.

9 Select **Print Information**.

Figure 2.69 List Format: Print Information Tab

<< Configuration Parameters > Format > List Format

Sample Program Format
List Format

Basic Condition
Print Information
Printed Test
Layout

List Name: 1.Patient Data List
List Type: Result(Seq.) Type

Header Width: 8
Sample Width: 4

Page Header		
Method	Title	Data
Device No.	<input checked="" type="checkbox"/>	<input checked="" type="checkbox"/>
List Name	<input checked="" type="checkbox"/>	<input checked="" type="checkbox"/>
Page	<input checked="" type="checkbox"/>	<input checked="" type="checkbox"/>
Index	<input type="checkbox"/>	<input type="checkbox"/>
Group	<input type="checkbox"/>	<input type="checkbox"/>
Print Time	<input checked="" type="checkbox"/>	<input checked="" type="checkbox"/>
Operator	<input checked="" type="checkbox"/>	<input checked="" type="checkbox"/>
Reporter	<input checked="" type="checkbox"/>	<input checked="" type="checkbox"/>

Sample Information		
Method	Title	Data
Sample No.	<input type="checkbox"/>	<input checked="" type="checkbox"/>
Rack ID-Cup Pos.	<input checked="" type="checkbox"/>	<input checked="" type="checkbox"/>
Sample ID	<input checked="" type="checkbox"/>	<input checked="" type="checkbox"/>
Sex	<input checked="" type="checkbox"/>	<input checked="" type="checkbox"/>
Age	<input checked="" type="checkbox"/>	<input checked="" type="checkbox"/>
Month	<input checked="" type="checkbox"/>	<input checked="" type="checkbox"/>
Other Type	<input checked="" type="checkbox"/>	<input checked="" type="checkbox"/>
Type	<input checked="" type="checkbox"/>	<input checked="" type="checkbox"/>
Sample Vol.	<input checked="" type="checkbox"/>	<input checked="" type="checkbox"/>
Sample Dilution Rate	<input checked="" type="checkbox"/>	<input checked="" type="checkbox"/>
Patient Info. 1	<input checked="" type="checkbox"/>	<input checked="" type="checkbox"/>
Patient Info. 2	<input checked="" type="checkbox"/>	<input checked="" type="checkbox"/>
Patient Info. 3	<input checked="" type="checkbox"/>	<input checked="" type="checkbox"/>
Patient Info. 4	<input checked="" type="checkbox"/>	<input checked="" type="checkbox"/>
Patient Info. 5	<input checked="" type="checkbox"/>	<input checked="" type="checkbox"/>
Patient Info. 6	<input checked="" type="checkbox"/>	<input checked="" type="checkbox"/>
Patient Comment	<input checked="" type="checkbox"/>	<input checked="" type="checkbox"/>
Sample Name	<input type="checkbox"/>	<input type="checkbox"/>
Kind No.-Seq. No.	<input type="checkbox"/>	<input type="checkbox"/>
Lot No.	<input type="checkbox"/>	<input type="checkbox"/>
Run Date/Time	<input checked="" type="checkbox"/>	<input checked="" type="checkbox"/>

Test Information		
Method	Title	Data
Test Name	-	<input checked="" type="checkbox"/>
Test Dilution	-	<input checked="" type="checkbox"/>
Pre-Dilution Rate	-	<input type="checkbox"/>
Result	-	<input checked="" type="checkbox"/>
Flags	-	<input checked="" type="checkbox"/>
R. Bottle Info.	-	<input type="checkbox"/>
ISE Info	-	<input type="checkbox"/>
Unit	-	<input checked="" type="checkbox"/>
Reference Interval	-	<input checked="" type="checkbox"/>
Output	<input type="checkbox"/>	<input type="checkbox"/>

Tail Information	
Method	Output
Total Tests	<input type="checkbox"/>
Total Samples	<input type="checkbox"/>
Reagent Consumption	<input type="checkbox"/>
Tail Name	<input type="checkbox"/>

Edit F1
Print F8

10 Select the information to print on the list.

11 Select Printed Test.

Figure 2.70 List Format: Printed Test Tab

Sample Program Format
List Format

Basic Condition
Print Information
Printed Test
Layout

List Name: 1.Patient Data List
List Type: Result(Seq.) Type

Selected Tests
118
1

1.ALB	2.ALP	3.ALT	4.AMY	5.AST	6.CO2	7.DBILC	8.DBB
9.TBILC	10.TBB	11.CA	12.	13.	14.	15.	16.
17.	18.	19.	20.	21.IRON	22.	23.	24.
25.	26.	27.	28.	29.	30.	31.	32.
33.	34.	35.	36.	37.	38.	39.	40.
41.	42.UBCr	43.	44.	45.	46.	47.	48.
49.	50.	51.	52.	53.	54.	55.	56.
57.	58.	59.	60.	61.	62.	63.	64.
65.	66.	67.	68.	69.	70.	71.	72.
73.	74.	75.	76.	77.	78.	79.	80.
81.	82.	83.	84.	85.	86.	87.	88.
89.%SATr	90.	91.	92.	93.	94.	95.	96.LIH
97.Na	98.K	99.Cl	100.HbA1c	101.T-Hb	102.A1c	103.	104.
105	106.	107.	108.	109.	110.	111.	112.
113	114.	115.	116.	117.	118.	119.	120.

Edit F1
Select All Tests
Clear All Tests
Print F8

1. Selected Tests

12 Select the tests to print.

2-106

B71496AE

The selected tests change to blue. The number of selected tests displays in **Selected Tests**.

13 Select **Select All Tests** [F5] and **Clear All Tests** [F6], as required.

14 Select **Layout**.

Figure 2.71 List Format: Layout Tab

15 Select the item to print from **Layout Info**.

You can select an item only if you have programmed it to print in the Print Information tab. This requirement includes the options for page headers, sample information, test information, comments, and line options.

16 Select the column and line on the grid to start printing the selected item.

17 Select **Confirm**.

The system displays the allocated boxes in blue.

18 Repeat steps **15** and **16** for all layout information.

19 Confirm the information, and then select **Save** [F1].

Save Data to a File

The system saves data to a DxC 700 AU_List_Image.txt file, and does not print realtime when you select **Output File**.

1 Select **CONFIG. > List Format > Basic Condition**.

2 Select **Output File**.

Add or Change a Comment

Select **Fixed Comment** in the Basic Condition tab (**CONFIG. > List Format > Basic Condition**) before accessing the Comment dialog (**CONFIG. > List Format > Layout > Comment [F3]**).

-
- 1 Select **CONFIG. > List Format > Layout**.

 - 2 Select **Edit [F1]**.

 - 3 Select **Comment [F3]**.

 - 4 Enter a comment (maximum of 20 characters) in **Comment**.

 - 5 Select **Horizontal** or **Vertical** in **Direction**.

 - 6 Select **OK**.

 - 7 Select the comment in **Layout Info**. The squares available to format the selected item display in white.

 - 8 Select the position on the grid to start printing the selected item. Select **Confirm**. The system displays the allocated boxes in blue.

 - 9 Confirm the information, and then select **Save [F1]**.
-

Program Realtime Print Options

You must select a list format for patient samples, reagent blank, calibration, and QC to enable realtime printing.

-
- 1 Select **CONFIG. > List Format > Basic Condition**.

Figure 2.72 List Format: Basic Condition Tab

<< Configuration Parameters > Format > List Format

2 Select **Edit** [F1].**3** Select **Realtime List** [F5].

The Realtime List dialog opens.

Figure 2.73 Realtime List Dialog

Table 2.47 Realtime List Dialog Description

Option	Description
Realtime List	Select to enable realtime printing.
Realtime Print	Select the list format for Patient, Calibration, RB, and QC .
Quick Output	When selected, one sample prints when it is complete per page.

Parameters

Lipemia, Icterus, and Hemolysis (LIH)

Table 2.47 Realtime List Dialog Description (Continued)

Option	Description
Quick Tests	When selected, the system prints quick test results from samples processed on the STAT table before the normal print time for all tests on a sample. Quick test results are those test results with R1 only (read points before P10) and ISE tests.

- 4 Select **Realtime List**.
- 5 Select a list format for **Patient, Calibration, RB, and QC**.
- 6 If you want a printout for each sample of each applicable sample type, select sample types in **Quick Output**.
- 7 Select **OK**.
The Realtime List dialog is closed.
- 8 Select **Save [F1]**.

Lipemia, Icterus, and Hemolysis (LIH)

LIH Reagent OSR62166 is a photometric test for the semi-quantitative assessment of lipemia/turbidity, icterus, and hemolysis (LIH) in human serum and plasma on the analyzer.

Several diseases and pre-analytical conditions can cause increased concentrations of chromogens like bilirubin, hemoglobin, and lipids/turbidity in body fluids. Chromogens can interfere with photometric tests.

The system dilutes patient samples with the LIH reagent and measures the absorbance at six wavelengths. If one or more chromogens in a potentially interfering concentration is present in a sample, the system generates and reports applicable flags along with the results of the sample. These flags characterize the type of chromatic substance (LIP: lipemia/turbidity, ICT: bilirubin, HEM: hemoglobin) and the approximate concentration of the interferents.

The following table shows the approximate concentration of chromatic substance.



The concentrations listed in the table are for reference only. Depending on the matrix effect with an individual serum sample, some results might not meet the listed concentrations.

Table 2.48 Approximate Concentration of Chromatic Substance

Flag	LIP (mg/dL Intralipid)	ICT (mg/dL Bilirubin)	HEM (mg/dL Hemoglobin)
N	<40	<2.5	<50
+	40 to 99	2.5 - 4.9	50 to 99
++	100 to 199	5.0 - 9.9	100 to 199
+++	200 to 299	10.0 - 19.9	200 to 299
++++	300 to 500	20 to 40	300 to 500
+++++	>500	>40	>500

If a sample has one or more flags from the table, refer to the information on interfering substance in the reagent setting sheet to confirm the accuracy of the test results of that sample.

You can program the DxC 700 AU for sample-specific LIH and test-specific LIH. Sample-specific LIH tests the level of LIH in the sample. Test-specific LIH determines the effect this level of LIH has on individual tests.

1. Sample-specific LIH: The system optically identifies the level of lipemia, icterus, or hemolysis by measuring the sample and LIH reagent in the cuvette. Based on the programmed absorbance limits for lipemia, icterus, and hemolysis in the LIH test, the system generates a flag for each interfering substance as N (normal), +, ++, +++, +++++, ++++++, ABN-L (abnormal low), or ABN-H (abnormal high).

Each sample displays the results of the LIH Test. For example:

- LIP +
- ICT N
- HEM ++

2. Test-specific LIH: The level of lipemia, icterus, or hemolysis in the sample determines the effect on individual tests. Each specific test generates l, i, or h flags if it exceeds the lipemia, icterus, or hemolysis limit. For example, the result of a DBIL affected by the level of hemolysis in the sample:

- DBIL 0.3 h

LIH Reagent

LIH Reagent (OSR62166) is the only reagent validated for test-specific LIH testing.

The LIH Reagent kit contains 16 bottles, and 2,400 tests can be processed per bottle. The LIH Reagent functions as R1. The Onboard Stability is 90 days.

Program LIH

-
- 1 Select **CONFIG. > Test Name Parameters > Test Name.**

Parameters

Lipemia, Icterus, and Hemolysis (LIH)

Figure 2.74 Test Name Parameters: Test Name Tab

Test Name Parameters		Panel	Group of Tests			
Test Name		Common Reagents				
LIH Reagent		Dedicated				
		<Editing>				
No.	Test Name	Long Name	Reagent ID	Alarm Tests	Multi Reagent Switch	Reagent Detail
91				32	No	
92				32	No	
93				32	No	
94				32	No	
95				32	No	
96	LIH	Serum Indices		32	---	
97	Na	Sodium	---	---	---	
98	K	Potassium	---	---	---	
99	Cl	Chloride	---	---	---	
100	HbA1c			32	Yes	
101	T-Hb			---	Yes	
102	A1c			---	Yes	
103				32	No	
104				32	No	
105				32	No	
106				32	No	
107				32	No	
108				32	No	
109				32	No	
110				32	No	

Save F1				Sample Blank F5	Calculated Tests F6	Delete Test Parameters F7
------------	--	--	--	--------------------	------------------------	---------------------------------

- a. Select **Edit** [F1].
- b. Select No. **96**.
- c. In **Reagent ID**, enter 166.
- d. In **Alarm Tests**, enter the number of tests that the system generates a Reagent Insufficient event. The default is 32.
- e. In **LIH Reagent**, select **Dedicated**.
- f. Confirm the information, and then select **Save** [F1].

2 Select **CONFIG. > Group of Tests**.

Parameters

Lipemia, Icterus, and Hemolysis (LIH)

Figure 2.76 Test Volume and Methods: LIH Tab

Test Volume and Methods		Rerun Test Parameters		Rerun Check Parameters		
General	LIH	ISE	HbA1c	Calculated Tests	Range	
Test Name	96 LIH	LIH Reagent	Dedicated			
Sample Volume	2.0 uL	Dilution	0 uL			
Reagent Volume	R1(R1-1) 25 uL	Dilution	125 uL			
Onboard Stability Period	Day		Hour			
LIH Judgement Level						
	Lipemia	Icterus	Hemolysis			
+	0.0000	0.0000	0.0000			
++	0.0000	0.0000	0.0000			
+++	0.0000	0.0000	0.0000			
++++	0.0000	0.0000	0.0000			
*****	0.0000	0.0000	0.0000			
Edit F1						Print F8

- Select **Edit** [F1].
- Enter the parameters from the LIH reagent setting sheet.
- Confirm the information, and then select **Save** [F1].

4 Select **CONFIG.** > **Test Volume and Methods** > **General**.



Note

You can program **LIH Influence Check** only for the Serum sample type. If Beckman Coulter enables the System Maintenance menu for Other-1 and Other-2, all programmed LIH values affect Other-1 and Other-2 sample types.

Figure 2.77 Test Volume and Methods: General Tab

Test Volume and Methods		Rerun Test Parameters		Rerun Check Parameters						
General		LIH	ISE	HbA1c	Calculated Tests	Range				
Test Name	1 ALB	Test No.		Type	Serum	Operation	No			
Sample Volume	1.6 uL	Dilution	0 uL	OD Limit		Min.OD		Max.OD		
Pre-Dilution Rate	1			Reagent OD Limit		1st	Low	-2.0000	High	3.0000
Reagent Volume	R1(R1-1) 15 uL	Dilution	0 uL	Last		Low	-2.0000	High	3.0000	
	R1-2	Dilution		Analytical Measuring Range		Low	-9999999	High	9999999	
	R2(R2-1) 0 uL	Dilution	0 uL	Correlation Factor		A	1	B	0	
Common Reagent	Type	None	Name	None		Manufacturer Factor	A	1	B	0
Wavelength	Pri.	340 nm	Sec.	None nm						
Method		END								
Reaction Slope		+ -				Onboard Stability Period		Day		Hour
Measuring Point-1	1st.	0	Last	27		LIH Influence Check		No		
Measuring Point-2	1st.		Last			Lipemia		+ -		
Linearity Limit		%				Icterus		+ -		
Lag Time Check		-				Hemolysis		+ -		
Edit F1						List Display F7		Print F8		

- a. Select **Edit** [F1].
- b. In **Test Name**, select a test to program test-specific LIH parameters.
For example, in [Figure 2.74 Test Name Parameters: Test Name Tab](#), **GLU** is selected in **Test Name**.
- c. Select **Yes** in **LIH Influence Check** to perform test-specific LIH analysis. Select **No** in **LIH Influence Check** if test-specific LIH analysis is not required for a test.
Refer to the reagent setting sheet for each specific test for the test-specific LIH parameters. For example, for [Figure 2.74 Test Name Parameters: Test Name Tab](#), refer to the Glucose (GLU) reagent setting sheet.
- d. Repeat for all tests in the Groups.
- e. Confirm the information, and then select **Save** [F1].

5 Select **CONFIG. > List Format > Printed Test**.

- a. Select **Edit** [F1].
- b. Select LIH to add it to all required printouts and lists.
Select **List Name** to refer to a list of all the realtime printouts and lists available.
- c. Confirm the information, and then select **Save** [F1].

Running the LIH Test

- The system requires one extra cycle time (4.5 seconds) per sample to run the LIH test.
- Place the bar coded LIH reagent bottle in the R1 refrigerator and follow procedures for checking reagents.
- You can program LIH for automatic orders on all samples or you can order it for individual samples as needed. If you program LIH for automatic orders on all samples, LIH is highlighted in blue in the Test Order tab (**TEST > Rack (Patient) > Test Order**).

Parameters

Lipemia, Icterus, and Hemolysis (LIH)

Order LIH using normal procedures. You can order LIH by realtime query with the LIS, or manually.

- LIH results print automatically.
- LIH criteria only apply to Serum, Other-1, and Other-2 sample types. For Urine sample types, the LIH test is unavailable and is not operational.

Sample Programming and Processing

Cautions with Cups or Tubes Specifications



Warning

Use only sample cups and tubes listed in the specifications and validated by Beckman Coulter. If other cups or tubes are used, analysis cannot be performed or errors can result.



Note

BD indicates a Becton Dickinson PN. You can use the BD tube or its equivalent.

Cup or Tube Available for Racks or STAT Table

Table 3.1 Cup or Tube Available for Racks or STAT Table

Cup or Tube	Size	PN	Dead Volume (μL)	Dead Volume (μL) for 3 and 5 Pre-Dilution Rate	Dead Volume (μL) when Connected to Laboratory Automation System
Hitachi cup	2.5 mL	MU853200	50	80	N/A for samples from automation line
					50 (or 80) for samples on the STAT table
Auto aliquot tube	13 mm	2910034	80	80	300
Serum Separator Tube	13 x 100 mm	BD 367986	4 mm above the non-sample (cells or gel) layer	4 mm above the non-sample (cells or gel) layer	4 mm above the non-sample (cells or gel) layer
Serum Separator Tube	16 x 100 mm	BD 367988	4 mm above the non-sample (cells or gel) layer	4 mm above the non-sample (cells or gel) layer	4 mm above the non-sample (cells or gel) layer
Lithium heparin with gel separator (light green top)	13 x 75 mm	BD 367960	4 mm above the non-sample (cells or gel) layer	4 mm above the non-sample (cells or gel) layer	4 mm above the non-sample (cells or gel) layer

Sample Programming and Processing
Cautions with Cups or Tubes Specifications

Table 3.1 Cup or Tube Available for Racks or STAT Table (Continued)

Cup or Tube	Size	PN	Dead Volume (µL)	Dead Volume (µL) for 3 and 5 Pre-Dilution Rate	Dead Volume (µL) when Connected to Laboratory Automation System
Lithium heparin with gel separator (light green top)	13 x 100 mm	BD 367962	4 mm above the non-sample (cells or gel) layer	4 mm above the non-sample (cells or gel) layer	4 mm above the non-sample (cells or gel) layer
Lithium heparin (green top)	13 x 75 mm	BD 367884	4 mm above the non-sample (cells or gel) layer	4 mm above the non-sample (cells or gel) layer	4 mm above the non-sample (cells or gel) layer
Lithium heparin (green top)	13 x 100 mm	BD 367886	4 mm above the non-sample (cells or gel) layer	4 mm above the non-sample (cells or gel) layer	4 mm above the non-sample (cells or gel) layer
Primary tube (red top)	13 x 75 mm	BD 366668	140	140	300
Primary tube (red top)	13 x 100 mm	BD 367815	140	140	300

Cup Nested (Inserted) in Tube Available for Racks

Table 3.2 Cup Nested (Inserted) in Tube Available for Racks

Cup, Size	PN	Tube	PN	Dead Volume (µL)	Dead Volume (µL) for 3 and 5 Pre-Dilution Rate
DxC cup, 2.0 mL	652730	DxC transfer	979272	50	200
Access 2 cup, 2.0 mL	81902	DxC transfer	979272	50	200
Access 2 cup, 1.0 mL	81915	13 x 75 mm	BD 367960 BD 367884 BD 366668	140	140
Access 2 cup, 1.0 mL	81915	13 x 100 mm	BD 367962 BD 367886 BD 367815	140	140

Table 3.2 Cup Nested (Inserted) in Tube Available for Racks (Continued)

Cup, Size	PN	Tube	PN	Dead Volume (µL)	Dead Volume (µL) for 3 and 5 Pre-Dilution Rate
Hitachi cup • Sample Cup 2.5 mL	MU853200	SST 16x100 mm	BD 367988	50	80
EZ Nest cup	1270013000	13 x 75 mm	BD 367960 BD 367884 BD 366668	50	150
EZ Nest cup	1270013000	13 x 100 mm	BD 367962 BD 367886 BD 367815	50	150
EZ Nest cup	1270016000	16 x 75 mm	BD 364976	50	120
EZ Nest cup	1270016000	16 x 100 mm	BD 367988	50	120

Cup Nested (Inserted) in Tube Available for STAT Table

Table 3.3 Cup Nested (Inserted) in Tube Available for STAT Table

Cup, Size	PN	Tube	PN	Dead Volume (µL)	Dead Volume (µL) for 3 and 5 Pre-Dilution Rate
DxC cup, 2.0 mL	652730	DxC transfer	979272	50	200
Access 2 cup, 2.0 mL	81902	DxC transfer	979272	50	200
Access 2 cup, 1.0 mL	81915	13 x 75 mm	BD 367960 BD 367884 BD 366668	140	140
EZ Nest cup	1270013000	13 x 75 mm	BD 367960 BD 367884 BD 366668	50	150

Sample Programming and Processing

Cautions with Cups or Tubes Specifications

Table 3.3 Cup Nested (Inserted) in Tube Available for STAT Table (Continued)

Cup, Size	PN	Tube	PN	Dead Volume (μL)	Dead Volume (μL) for 3 and 5 Pre-Dilution Rate
EZ Nest cup	1270016000	16 x 75 mm	BD 364976	50	120

Cup or Tube Restrictions for Racks

The analyzer has five sensors to detect the height of the cup or tube in a rack. The following restrictions apply when using more than one cup or tube simultaneously:

1. One type of cup or tube can be selected for each sensor.
2. More than one type of cup or tube can be selected for each sensor only if the cup or tube is the same Level: A, B, C, D, E, or F.



Warning

If more than one type of cup or tube is in use for a sensor, and the cup or tube is a different level (A, B, C, D, E, or F):

- If the maximum probe stroke is programmed to the shortest cup or tube, it is possible that the system cannot aspirate the sample in the longest cup or tube even though there is sufficient volume of sample, and generates a **Sample Empty** event.
- If the maximum probe stroke is programmed to the longest cup or tube, the shortest cup or tube must contain sufficient sample to avoid a probe crash.
- If the DxC 700 AU connects to a Laboratory Automation System, the probe can have only one probe downward stroke programmed, and you can use only one type of sample tube or cup.

Table 3.4 Cup or Tube Restrictions for Racks

Sensor	Level	Cup or Tube	Tube	
1	A	Hitachi cup	MU853200	
2	A	Lithium heparin with gel separator (light green top)	BD 367960	
	A	Lithium heparin (green top)	BD 367884	
	A	Primary tube (red top)	BD 366668	
	B	DxC cup	652730	DxC transfer tube (979272)
	B	Access 2 cup	81902	
	C	Access 2 cup	81915	13 x 75 mm tube
	D	EZ Nest cup	1270013000	16 x 75 mm tube
E	EZ Nest cup	1270016000		
3	A	Hitachi cup	MU853200	16 x 75 mm tube
4	A	Serum Separator Tube	BD 367986	

Table 3.4 Cup or Tube Restrictions for Racks (Continued)

Sensor	Level	Cup or Tube		Tube
	A	Lithium heparin with gel separator (light green top)	BD 367962	
	A	Lithium heparin (green top)	BD 367886	
	B	Auto aliquot tube	2910034	
	C	Access 2 cup	81915	13 x 100 mm tube
	D	EZ Nest cup	1270013000	
	E	EZ Nest cup	1270016000	16 x 100 mm tube
5	A	Hitachi cup	MU853200	16 x 100 mm tube

The default probe setting in the software for each cup and tube is Level A. If using a cup or tube other than Level A, contact Beckman Coulter. Beckman Coulter must make probe setting changes.

Figure 3.1 Sample Probe Stroke and Cup or Tube Height

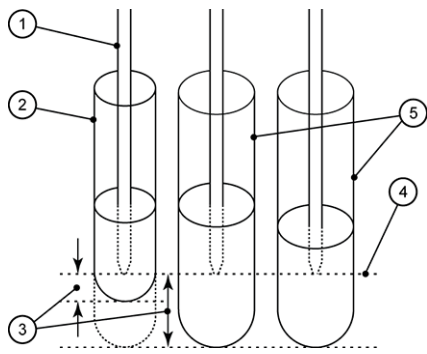

- | | |
|----------------------------------------------------------------------------------------------------------------------------|--------------------------------------------------------------------------------------------------------------------|
| <ol style="list-style-type: none"> 1. Sample probe 2. Shortest cup or tube 3. Dead volume | <ol style="list-style-type: none"> 4. Maximum probe downward stroke 5. Longest cup or tube |
|----------------------------------------------------------------------------------------------------------------------------|--------------------------------------------------------------------------------------------------------------------|

The maximum outer tube or cup diameter is 16 mm, including the thickness of a sample bar code label. If the tube or cup has a protrusion or lip at the top, the maximum outer diameter is 17.5 mm. If the diameter is greater than 17.5 mm, the tubes do not fit correctly when placed next to each other in the rack.

Sample Programming and Processing
Cautions with Cups or Tubes Specifications

Figure 3.2 Maximum Outer Cup or Tube Diameter

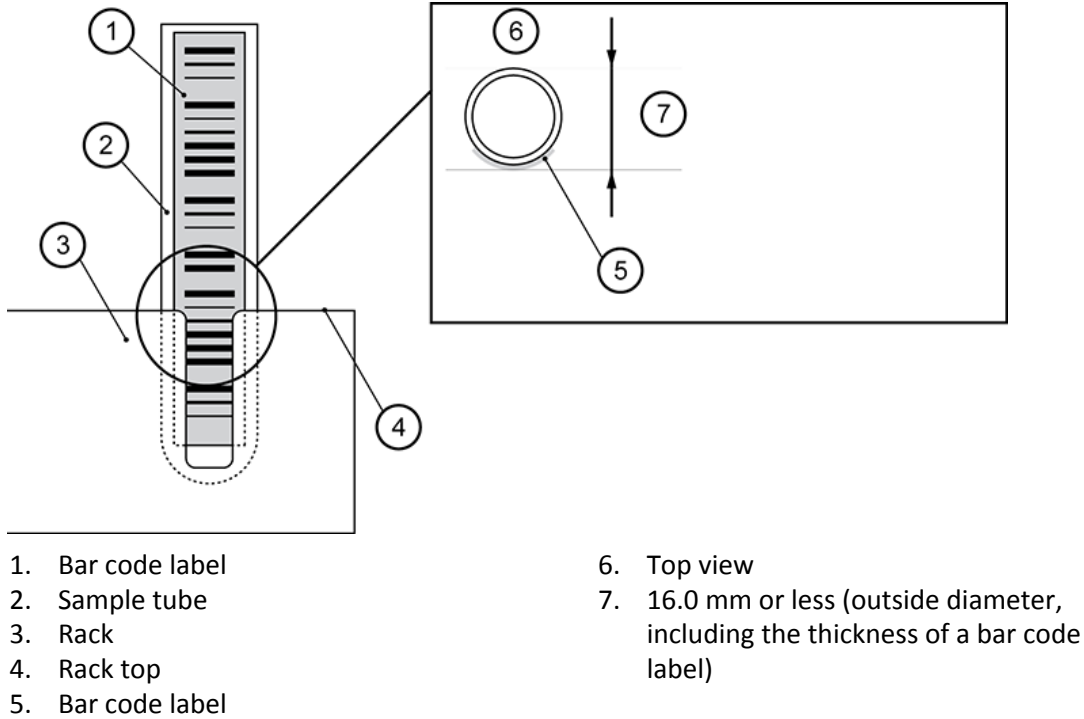

Cup or Tube Restrictions for the STAT Table

Table 3.5 Cup or Tube Restrictions for STAT Table

Sensor	Level	Cup or Tube		Tube
1	A	Hitachi cup	MU853200	
2	A	Lithium heparin with gel separator (light green top)	BD 367960	
	A	Lithium heparin (green top)	BD 367884	
	A	Primary tube (red top)	BD 366668	
	B	DxC cup	652730	DxC transfer tube (979272)
	B	Access 2 cup	81902	
	C	Access 2 cup	81915	13 x 75 mm tube
	D	EZ Nest cup	1270013000	
E	EZ Nest cup	1270016000	16 x 75 mm tube	
3	A	Hitachi cup	MU853200	16 x 75 mm tube
4	A	Serum Separator Tube	BD 367986	
	A	Lithium heparin with gel separator (light green top)	BD 367962	
	A	Lithium heparin (green top)	BD 367886	

Table 3.5 Cup or Tube Restrictions for STAT Table (Continued)

Sensor	Level	Cup or Tube		Tube
	B	Auto aliquot tube	2910034	

Apply Bar Code Labels to Sample Tubes

Warning

The bar code reader might not identify long or short bar code labels.

Bar code labels must not protrude from the top of a sample cup or tube. Position the label perpendicularly. The inclination angle must be 5° or less.

For more information on bar code label specifications, refer to [Sample Bar Code Label Specifications](#).

Note

Refer to the Laboratory Automation System manual for applying bar code labels to sample cups when the DxC 700 AU is connected to a Laboratory Automation System.

- 1 Affix the bar code labels to the outside of the sample tube so that the end of each label is a minimum of 7 mm from the bottom of the cup, and the angle is within a maximum of 5°.
- 2 Using your finger, rub the label gently to attach it firmly so that it does not peel off.

Figure 3.3 Sample ID Bar Code Label Application

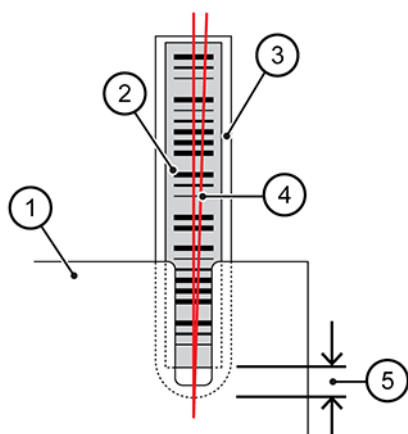

1. NE rack
2. Bar code label
3. Sample tube
4. The inclination angle must be 5° or less
5. 7 mm minimum

NE Racks

An NE rack has a slit that allows you to place the bar code label below the top surface of the rack. The NE rack allows for various tube diameters to be used with or without adapters. Use only NE racks on the DxC 700 AU.

Figure 3.4 NE Rack with Tube

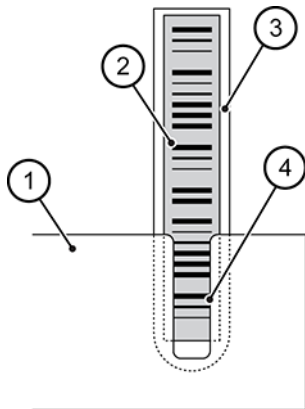

- | | |
|-------------------|--------------------|
| 1. NE rack | 3. Sample tube |
| 2. Bar code label | 4. Slit in NE rack |

Bar Code Labels for STAT Table Analysis

The outer positions (1 to 22) are used for STAT analysis. Place the tube on the table with the bar code label facing out from the center of the table.

Figure 3.5 Placing Tubes with Bar Code Labels on the STAT Table

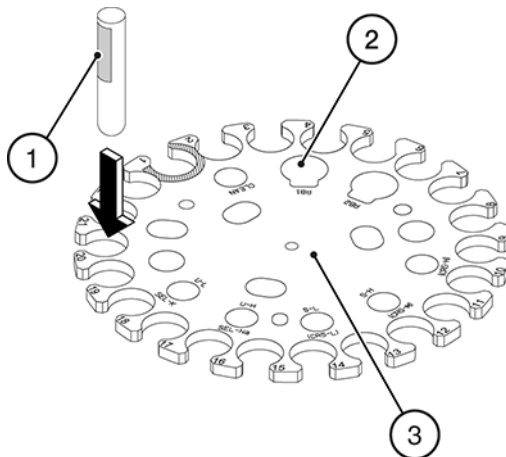

- | | |
|--------------------------------------------------------------------------------------------------|---------------------------------------------------------|
| 1. Place the tube in outer position 1-22 with the label facing out from the center of the table. | 2. Inner positions are not available for bar code mode. |
| | 3. STAT table |

Apply a Rack ID Bar Code Label on the Rack

Apply a bar code label to all racks except the blue rack (yellow, green, white, and red) before processing them.

Apply the rack ID label to the front of the rack, perpendicular to the protruding part of the rack. Refer to [Figure 3.6 Rack ID Bar Code Label Application](#). The units are in mm.

Figure 3.6 Rack ID Bar Code Label Application

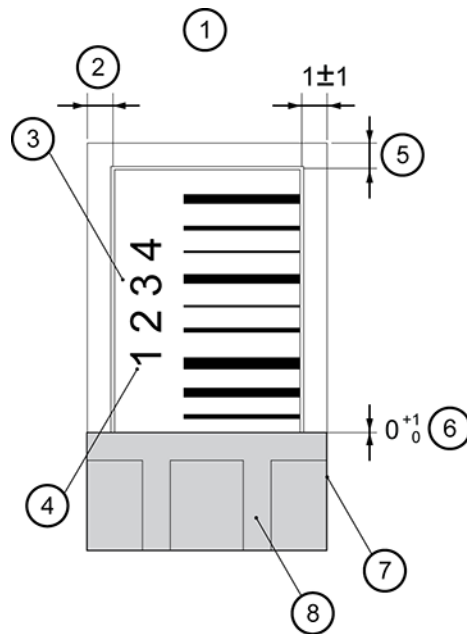

- | | |
|----------------------------------------------------------------------------------------------------------------------------------------------------------------------------------------------------------------------------------------------------------------------------------------------------------------------------|-------------------------------------------------------------------------------------------------------------------------------------------------------------------------------------------------------------------------------------------------|
| <ol style="list-style-type: none"> 1. Rack front 2. Confirm that the label does not protrude from the rack 3. Rack ID label (Attach the label on the rack parallel with the side face.) 4. Orient the label so that the numbers are located to the left if viewed from the front | <ol style="list-style-type: none"> 5. Confirm that the label does not protrude from the rack 6. Do not place the label on the protruding part of the rack 7. Rack side 8. Protruding part of the rack |
|----------------------------------------------------------------------------------------------------------------------------------------------------------------------------------------------------------------------------------------------------------------------------------------------------------------------------|-------------------------------------------------------------------------------------------------------------------------------------------------------------------------------------------------------------------------------------------------|

 **Warning**

The system might read bar code labels in bad condition incorrectly. If you observe any of the following conditions, replace bar code labels:

- The bar code label is smudged, scratched, or damaged.
- The bar code label is stained or dirty.
- The bar code label is torn or peeling.

Sample Programming and Processing

Use Adapters on Sample Racks

Use Adapters on Sample Racks

To hold smaller diameter tubes (approximately 11.5 mm to 13.5 mm) firmly in position in the racks, use adapters. Larger diameter tubes (approximately 13.6 mm to 16 mm) do not require adapters.

To decide whether to use an adapter, place the tube into a rack with and without an adapter, and observe which option holds the tube to the center of the rack position.

Insert an Adapter into a Rack

Figure 3.7 Insert an Adapter into a Rack

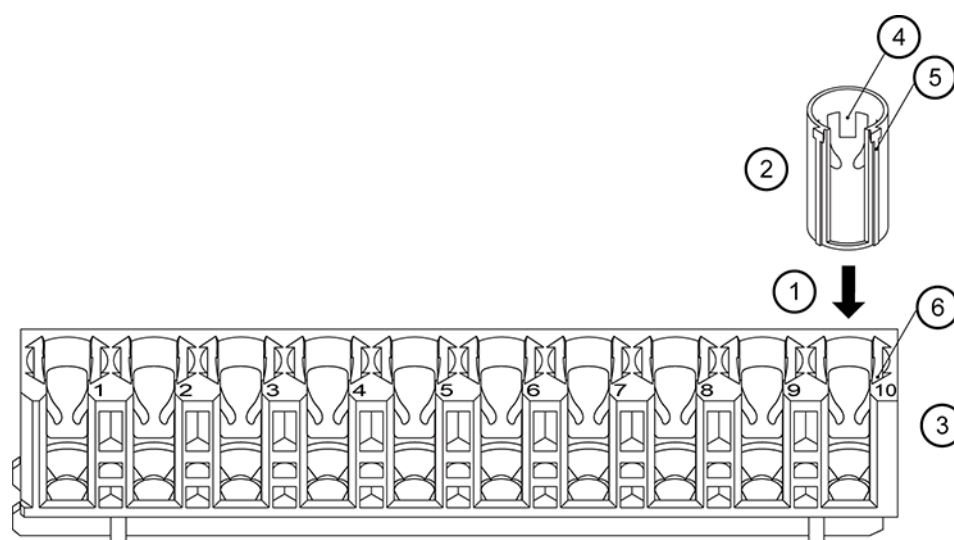

- | | |
|------------|-----------------|
| 1. Push in | 4. Adapter lock |
| 2. Adapter | 5. Guide |
| 3. Rack | 6. Guide groove |

- 1 Align the adapter opening and the rack opening.
- 2 Insert the adapter guide into the guide groove of the rack.
- 3 Push the adapter into the rack until you hear a click.
- 4 Be sure the adapter has engaged the rack.

Remove an Adapter from a Rack

Figure 3.8 Remove an Adapter from a Rack

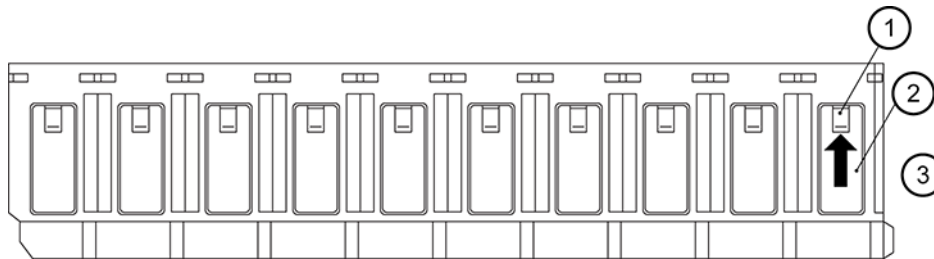

1. Adapter lock
2. Rack window
3. Push up lightly with a finger

-
- 1** To disengage the lock, push the adapter lock lightly with a finger from the outside of the rack window.
 - 2** When the upper edge of the adapter comes out from the rack, pull the remainder of the adapter out.
-

Sample Programming and Processing

Use Adapters on Sample Racks

System Monitoring and Results

Reagent Management

- 3 Select **Delete All** to delete all information for the test, and **Delete** to delete the line of information at the cursor.
The Reagent History dialog opens.
- 4 Select **OK**.
The selected information is deleted.
- 5 To close the dialog, select **Close**.

Recovering from a Bottle Position Error



Note

After a bottle position error occurs, confirm the reagent bottle status from the previous reagent check. You can access the Previous Setting dialog only in *PAUSE* mode.

The system displays **Bottle Position Error** in the Comment column in **Reagent Management > Details** and continues analysis. To move the system to *PAUSE* mode, select **Pause**.

- 1 Select **REAGENT > Reagent Management > Details**, and then select **Previous Setting**.

Figure 4.2 Previous Setting Dialog

Pos.	Test Name	R1/R2	Lot No.	Bottle No.	Seq.
1	ALT	R1(R1-1)			1
2	CHOL	R1(R1-1)			1
3	GGT19	R1(R1-1)			1
4	LDH	R1(R1-1)			1
5	UN	R1(R1-1)			1
6	GLUC	R1(R1-1)			1
7	CRP	R1(R1-1)			1
8	ALB	R1(R1-1)			1
9	AMY	R1(R1-1)			1
10	GLB	R1(R1-1)			1
11	T-Hb	R1(R1-1)	0001	0001	
12	DEHAT	R1(R1-1)	0001	0001	
13					
14					
15					
16					
17	HbA1c	R1(R1-1)	0001	0001	
18					
19					
20					

- 2 Select **R1** or **R2**.
The system displays reagent information.
- 3 Confirm the information, and select **Close**.

Initialize Onboard Stability

This function initializes the reagent onboard stability. You can initialize onboard stability only for reagents in fixed positions. You must enter a lot number and bottle number before the function becomes operational.

When replacing reagents in fixed positions to update the onboard stability, select **Initialize Onboard Stability** in the Details tab (**REAGENT > Reagent Management > Details**).

Reagent Inventory

The system can calculate the reagent volume required for each test for each day of the week from data obtained from the analyzer (in the Auto tab), or you can enter a value for each test for each day of the week (in the Manual tab).

The Reagent Inventory screen (**REAGENT > Reagent Inventory**) displays the number of tests used each day of the week for each sample type within the period set by the index range. Use the Reagent Inventory screen to determine the reagent volume required to be onboard for each day of the week.

The Reagent Management > Main tab (**REAGENT > Reagent Management > Main**) displays tests below the required volume for the day of the week in green. The indicator bar displays the volume using the percentage specified in **Margin**.

Auto Calculation of Reagent Inventory

- 1 Select **REAGENT > Reagent Inventory > Auto**.

Figure 4.3 Reagent Inventory: Auto Tab

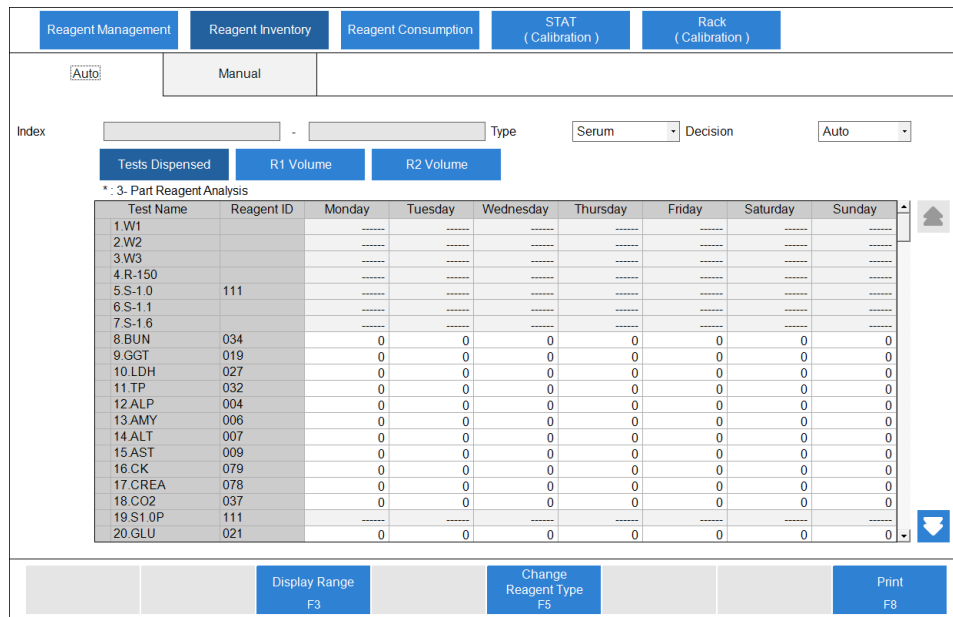

Test Name	Reagent ID	Monday	Tuesday	Wednesday	Thursday	Friday	Saturday	Sunday
1 W1		-----	-----	-----	-----	-----	-----	-----
2 W2		-----	-----	-----	-----	-----	-----	-----
3 W3		-----	-----	-----	-----	-----	-----	-----
4 R-150		-----	-----	-----	-----	-----	-----	-----
5 S-1-0	111	-----	-----	-----	-----	-----	-----	-----
6 S-1-1		-----	-----	-----	-----	-----	-----	-----
7 S-1-6		-----	-----	-----	-----	-----	-----	-----
8 BUN	034	0	0	0	0	0	0	0
9 GGT	019	0	0	0	0	0	0	0
10 LDH	027	0	0	0	0	0	0	0
11 TP	032	0	0	0	0	0	0	0
12 ALP	004	0	0	0	0	0	0	0
13 AMY	006	0	0	0	0	0	0	0
14 ALT	007	0	0	0	0	0	0	0
15 AST	009	0	0	0	0	0	0	0
16 CK	079	0	0	0	0	0	0	0
17 CREA	078	0	0	0	0	0	0	0
18 CO2	037	0	0	0	0	0	0	0
19 S1-0P	111	-----	-----	-----	-----	-----	-----	-----
20 GLU	021	0	0	0	0	0	0	0

Table 4.1 Auto Tab Description

Option	Description
Display Range [F3]	Select the start index and end index to calculate the reagent usage.
Change Reagent Type [F5]	Changes the display from information for the R1-1 to information for the R1-2 reagent. Only available when R1 Volume is selected.

- 2 Select the sample type in **Type**.
- 3 Select **Display Range** [F3].
The Display Range dialog opens.

Figure 4.4 Display Range Dialog

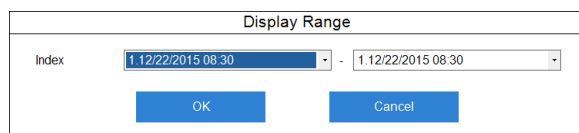

- 4 Select the start index and the end index.
You can select the indexes from the indexes one day before.
- 5 Select **OK**.
The system displays the number of tests selected within the index range in the list.
- 6 Select **R1 Volume** or **R2 Volume**. The reagent consumption is automatically calculated from a result and then displayed in the list in mL.
The system calculates the reagent consumption with the following formula:
$$\text{Actual result} \times (\text{the amount of reagent dispensing} + \text{the amount of surplus dispensing})$$
- 7 Select **Auto** in **Decision**. The system uses the calculated reagent consumption as the required reagent volume in the Reagent Management screen (**REAGENT > Reagent Management**).

Manual Calculation of Reagent Inventory

- 1 Select **REAGENT > Reagent Inventory > Manual**.
- 2 Select **Edit** [F1].
- 3 Select the sample type in **Type**.
- 4 Enter the number of tests run for each test for each day of the week.
- 5 Confirm that the information is correct, and then select **Save** [F1].
- 6 Select **R1 Volume** or **R2 Volume**.

The system automatically calculates the reagent consumption input from entered test numbers and then displays it in the list in mL.

7 Select Manual in Decision.

The system uses the test count entered for reagent consumption as the required reagent volume in the Reagent Management screen (**REAGENT > Reagent Management**).

Reagent Consumption

The Reagent Consumption screen displays the amount of reagent used for each test programmed on the analyzer. Set a range of indexes to display the reagent consumption used for analysis for each test by sample type.

1 Select REAGENT > Reagent Consumption.

Figure 4.5 Reagent Consumption Screen

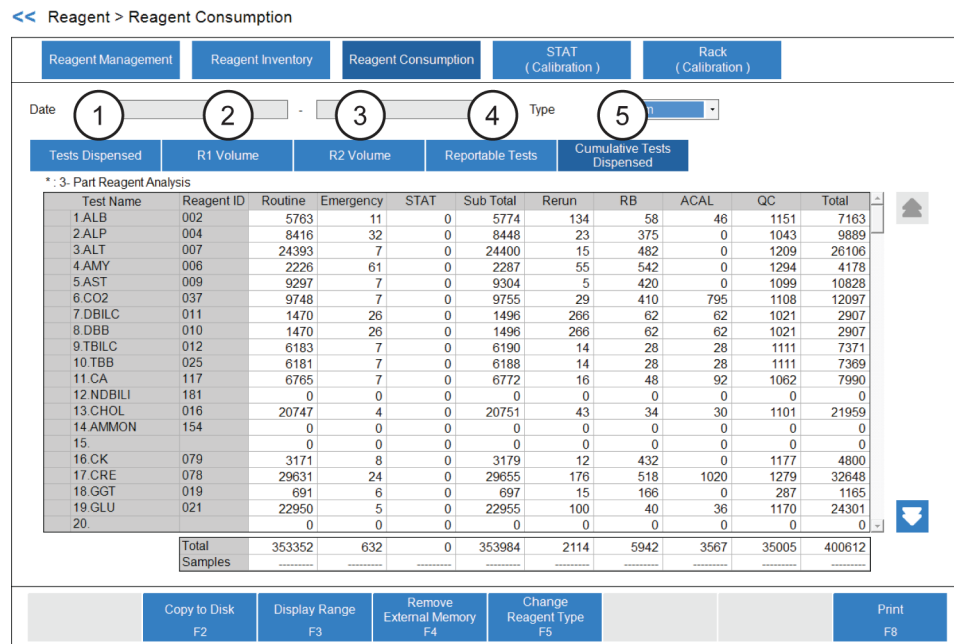

- 1. Tests dispensed
- 2. R1 volume
- 3. R2 volume
- 4. Reportable tests
- 5. Cumulative tests dispensed

The Reagent Consumption screen defaults to display the Shot Total tab. The shot total is the cumulative number of tests run on the analyzer since the installation of the analyzer.

2 Select the sample type in Type.

3 Select Display Range [F3].

4 Select the start date and end date in Date.

5 Select OK.

The system displays the number of cumulative tests.

Confirm Reagent Consumption by Samples Measured And Reagent Dispenses

- 1 After setting a range of dates to display the reagent consumption used for analysis for each test by sample type in the Reagent Consumption screen, select **Test Dispensed**. The system displays the Test Dispensed tab with the number of reagent dispenses, including for rerun tests, for each test and sample type.

The number of reagent dispenses displays for routine, emergency, STAT, and rerun samples, and for reagent blank, calibration, and QC.

The number of dispenses for ISE measurement displays as the number of ISE samples.

- 2 Select **R1 Volume** or **R2 Volume**.

The volume (in mL) of reagent dispensed for each test and sample type displays.

The system calculates the reagent consumption with the following formula:

Actual analysis result × (the amount of reagent dispensing + the amount of surplus dispensing)

- 3 After setting a range of dates to display the reagent consumption used for analysis for each test by sample type in the Reagent Consumption screen, select **Reportable Tests**. The system displays the Reportable Tests tab with the number of analyzed tests, not including for rerun tests, for each test and sample type.

The number of tests displays for routine, emergency, STAT, and rerun samples, and for reagent blank, calibration, and QC.

The number of dispenses for ISE measurement displays as the number of ISE tests (Na, K, and Cl).

Print Reagent Consumption Data

- 1 After setting a range of indexes to display the reagent consumption used for analysis for each test by sample type in the Reagent Consumption screen, select **Print** [F8].

- 2 Select all sample types.

- 3 Select **Test Shots**.

- 4 Select **OK**.

The system prints the reagent consumption data.

Save Reagent Consumption Data

- 1 After setting a range of indexes to display the reagent consumption used for analysis for each test by sample type in the Reagent Consumption screen, select **Copy to Disk** [F2].

-
- 2 Connect the external memory device or insert CD-R.

 - 3 Select **External Memory Device** or **CD-R**.

 - 4 Select **OK**. The system displays Copy to Disk dialog to ask to connect an external memory device or to insert a CD-R.

 - 5 Select **OK**. The system displays Copy to Disk dialog to ask to remove the external memory device or CD-R.

 - 6 Select **OK**.

 - 7 Remove the external memory device or CD-R.
-

Display Reaction Monitor

The Reaction Monitor screen displays sample information, reagent information, reaction data, and analyzer components used for analysis of reagent blank, calibration, QC, and samples. Inspect data or troubleshoot in the Reaction Monitor screen.

- Store a maximum of 100,000 samples, or 10,000 samples per index on the hard drive.
- Display a maximum of 200,000 tests on the Reaction Monitor screen.

-
- 1 Select **Result > Reaction Monitor** [F6].
The system displays the Reaction Monitor: General tab with the results for the current index.

 - 2 To search the results for a specific sample or in another index, select **Main**.
The system displays the Reaction Monitor: Main Tab (Patient).

Figure 4.6 Reaction Monitor: Main Tab (Patient)

The screenshot shows the 'Reaction Monitor' software interface. At the top, there are four tabs: 'Sample Manager', 'Reaction Monitor' (selected), 'Data Statistics', and 'Correlation Chart'. Below the tabs, there are two sub-tabs: 'Main' and 'General'. The 'Main' section contains two date pickers for 'Index' (both set to 3.12/08/2017 08:19), a 'Test Name' dropdown set to 'All', and two input fields for 'Cuvette No.' and 'Preprocess Cuvette No.' with an 'Abnormal' checkbox. Below this is a 'Patient' tab and an 'RB/Cal/QC' tab. The 'Patient' section includes fields for 'Mix Bar No.' (R11), 'Sample' (R21), and 'Preprocess'. A search table is displayed with columns for 'Sample Kind', 'Search by Sample No.', and 'Search by Sample ID'. The table lists 'Routine', 'Emergency', and 'STAT' sample kinds. Below the table are checkboxes for 'Type' (Serum, Urine, Other-1, Other-2, Whole Blood). At the bottom right, there is a 'Search Condition F5' button.

3 Specify the search parameters for the data to display, according to the following table.

Table 4.2 Main Tab (Patient) Description

Item	Contents	Input Notes
Index	Indexes	You can select from all available indexes, from the newest index to the oldest.
Test Name	All, or the abbreviated name of the test	You cannot select calculated tests.
Cuvette No.	1 to 165, or *	Specify the cuvette number used for analysis. Enter an asterisk to view every cuvette.
Preprocess Cuvette No.	1 to 165, or *	Specify the cuvette number used for pre-processing. Enter an asterisk to view every cuvette.
Mix Bar No.	1 to 3, or *	Specify the mix bar used for analysis in R1 (R11), Sample, R2 (R21), and Preprocess. Enter an asterisk to view every mix bar.
Sample Kind	Routine, Emergency, or STAT If programmed to one sample type in the same rack, the system displays the sample kind and sample type in the field for rack analysis.	Select the sample kind to search. You cannot select sample kinds that have not undergone processing.

Table 4.2 Main Tab (Patient) Description (Continued)

Item	Contents	Input Notes
Sample Type	Serum, Urine, Other-1, Other-2, or Whole Blood	Select the sample type to search.  Note You can select a sample type for any sample kind, except if the system is programmed to run one sample type in the same rack. With that programming, you can select a sample type for only the STAT sample kind.
Search by Sample No.	The starting and ending sample numbers, or * If no results for the sample kind exist, the system displays empty.	Leave the asterisk to search all of the numbers of samples that have undergone processing, or enter a specific sample number or range of sample numbers.
Search by Sample ID	A sample ID, or *	Leave the asterisk to search all sample IDs processed, or enter a specific sample ID.

4 Select **RB/Cal./QC**.

The system displays the Reaction Monitor: Main tab (RB/Cal./QC).

Figure 4.7 Reaction Monitor: Main Tab (RB/Cal./QC)

<< Results > Reaction Monitor

Sample Manager	Reaction Monitor	Data Statistics	Correlation Chart
Main	General		
Index	1.09/22/2015 16:23 - 1.09/22/2015 16:23		
Test Name	All		
Cuvette No.	<input type="text"/> * Preprocess Cuvette No. <input type="text"/> * <input type="checkbox"/> Abnormal		
			(Preprocess:Pre-dilution/Preprocess)
Patient	RB/Cal./QC	Mix Bar No. R11 <input type="text"/> * Sample <input type="text"/> * R21 <input type="text"/> * Preprocess <input type="text"/> *	
Sample Kind	Search by Sample No.	QC/Cal. No.	Search by Control / Calibrator ID
Calibration	-	*	*
QC	-	*	*
RB	R001 - R001	*	*
	Counts	Sequence	
Calibration	<input checked="" type="checkbox"/> 1 <input checked="" type="checkbox"/> 2 <input checked="" type="checkbox"/> 3 <input checked="" type="checkbox"/> 4	<input checked="" type="checkbox"/> 1 <input checked="" type="checkbox"/> 2 <input checked="" type="checkbox"/> 3 <input checked="" type="checkbox"/> 4 <input checked="" type="checkbox"/> 5	
QC		<input checked="" type="checkbox"/> 1 <input checked="" type="checkbox"/> 2 <input checked="" type="checkbox"/> 3 <input checked="" type="checkbox"/> 4 <input checked="" type="checkbox"/> 5	
RB	<input checked="" type="checkbox"/> 1 <input checked="" type="checkbox"/> 2 <input checked="" type="checkbox"/> 3 <input checked="" type="checkbox"/> 4	<input checked="" type="checkbox"/> 1 <input checked="" type="checkbox"/> 2 <input checked="" type="checkbox"/> 3 <input checked="" type="checkbox"/> 4 <input checked="" type="checkbox"/> 5	
			Search Condition F5

System Monitoring and Results

Display Reaction Monitor

- 5 Specify the search parameters for the data to display, according to the following table.

Table 4.3 Main Tab (RB/Cal./QC) Description

Item	Contents	Input Notes
Sample Kind	Calibration, QC, or RB	Select the sample kind to search. You cannot select sample kinds that have not undergone processing.
Search by Sample No.	The starting and ending sample numbers, or * If no results for the sample kind exist, the system displays empty.	Leave the asterisk to search all of the numbers of samples that have undergone processing, or enter a specific sample number or range of sample numbers.
QC/Cal No.	A control material or calibrator number, or *	Leave the asterisk to search all calibrator numbers or control material numbers processed, or enter a specific calibrator number or control material number.
Search by Control/ Calibrator ID	A control material or calibrator ID, or *	Leave the asterisk to search all calibrator IDs or control material IDs processed, or enter a specific calibrator ID or control material ID.
Counts	Select the boxes for counts for calibration and reagent blank, replicates 1 to 4.	Available only for Calibration and RB (reagent blank) data. Program the replicate number 1 to 4 in the Calibration Setup screen.
Sequence	Select the boxes for reagent bottle sequence 1 to 5 for calibration, QC, and reagent blank.	Available only for Calibration, QC, and RB (reagent blank) data. The serial reagent bottle number 1 to 5 for each test. When all boxes are cleared, the system displays data matching the specified sample number and bottle sequence number.

- 6 Select **General**.

The General tab displays. The search starts. If there is data that meets the search criteria, the General tab displays the first sample found. If the system finds no data meeting the search criteria, it displays a No Data Found message. Select **OK** to return to the Main tab.

- 7 Review the data in the General tab.

Figure 4.8 Reaction Monitor: General Tab

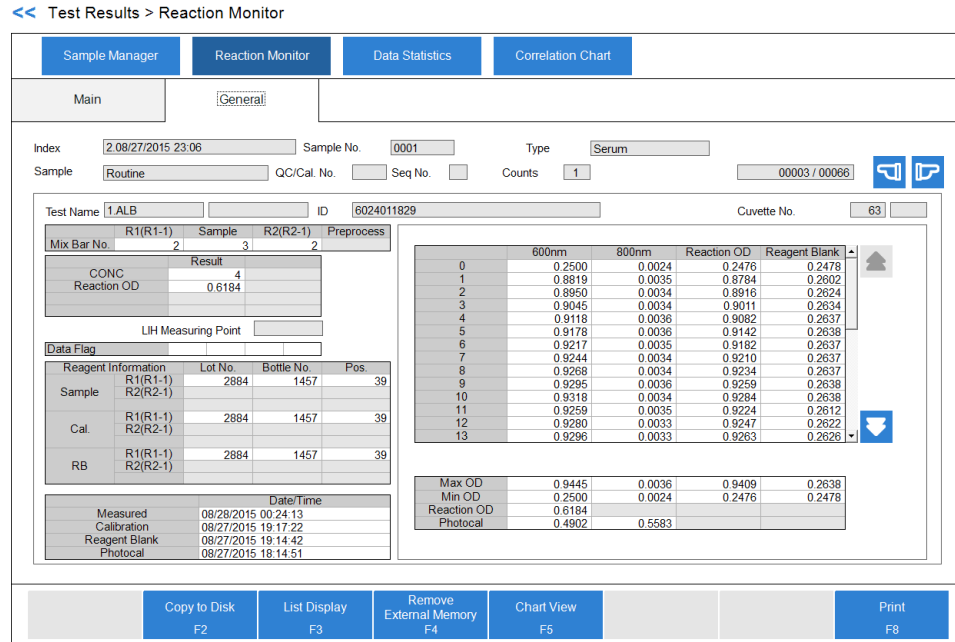

8 Select **Chart View** [F5].

The display changes to chart view. The chart includes colored lines for primary wavelength, secondary wavelength, and a calculation of the reaction absorbance.

Figure 4.9 Reaction Monitor: General Tab: Chart View [F5]

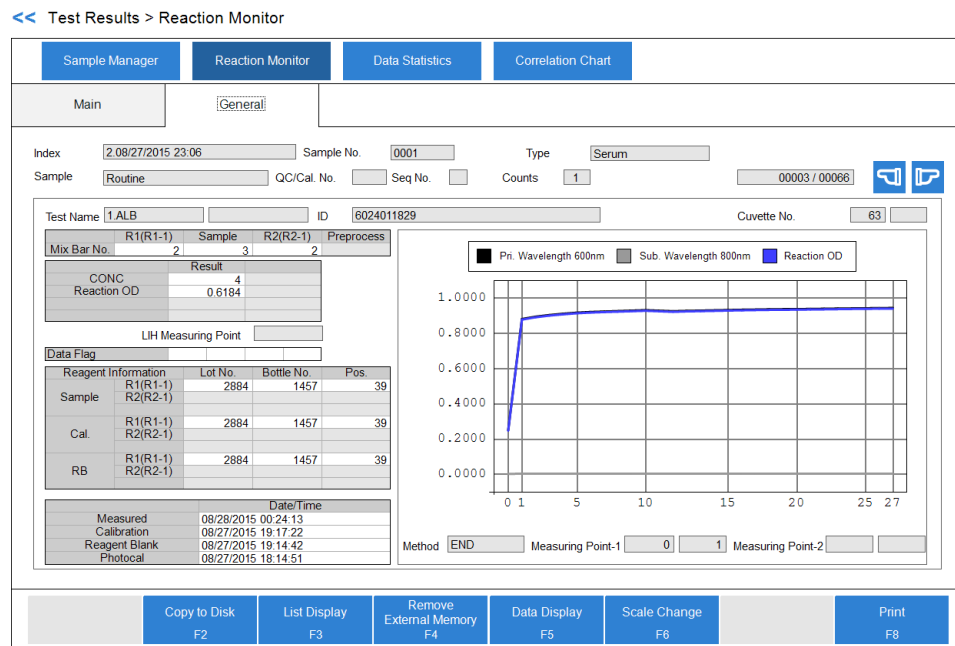

System Monitoring and Results

Monitor the Reagent Blank and Calibration



Note

When the total dispensing volume is below the minimum test volume¹, the chart displays dotted lines instead:

- If $(R1[R1-1] \text{ dispensing volume} + R1[R1-1] \text{ diluent quantity}) < \text{minimum test volume}^1$, the chart displays the straight line between P0 and P1 as a dotted line.
- If $(R1[R1-1] \text{ dispensing volume} + R1[R1-1] \text{ diluent quantity}) + (\text{sample dispensing volume} + \text{sample diluent quantity}) < \text{minimum test volume}^1$, the chart displays the straight lines between P0 and P10 as dotted lines.

9 To change the absorbance scale of the chart, select **Scale Change** [F6].
The Scale Change dialog displays.

10 Enter the lower limit value and the upper limit value and select **Manual**.
The setting range for the lower limit value and the upper limit value is from -2.000 to 3.000 (in units of 0.001). If you select **Auto**, the system sets the scale automatically.

Monitor the Reagent Blank and Calibration

Use the following procedure to monitor and confirm reagent blank and calibration results.

Reagent Blank and Calibration Status

1 Select **MENU > Calibration > Calibration Monitor > Status**.

¹ Minimum test volume:

120 μ L (for all countries and regions except Japan)

90 μ L (for Japan only)

Figure 4.10 Calibration Monitor: Status Tab

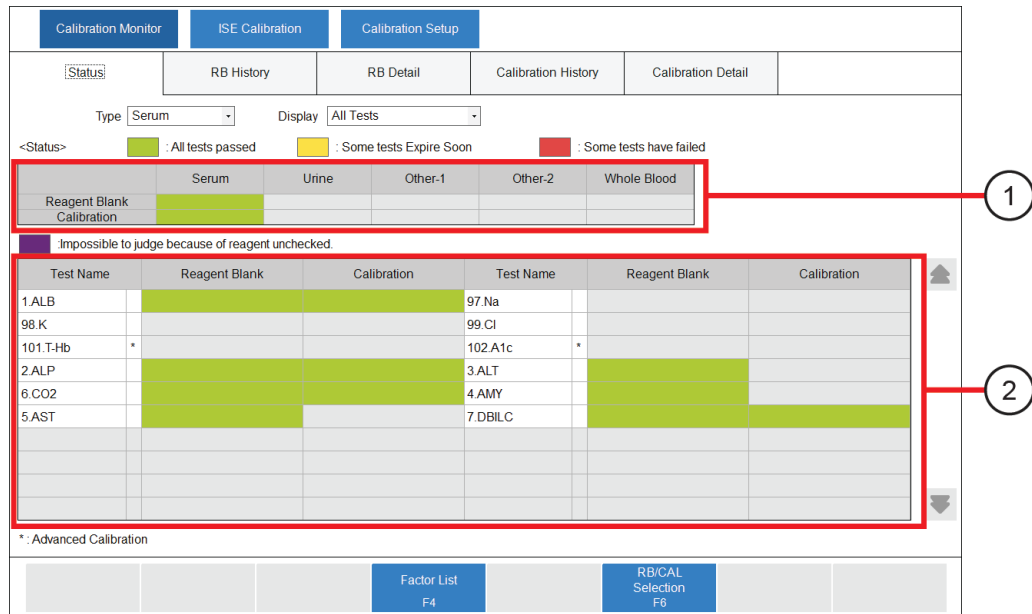

1. Sample Type list

2. Test list

Table 4.4 Sample Type List

Color	Status
Red	No data, Failed, or Expired.
Gray	The sample type is not available according to the selection in Type .
Green	No errors.
Yellow	The calibration expires soon.

Table 4.5 Test List

Display	Color	Status
No data	Red	Bottles without calibration data exist.
Failed		Bottles with failed calibrations exist.
Expired		Bottles with expired calibrations exist.
Expires soon	Yellow	Bottles with calibration data that expires soon exist.
Passed RB or Passed Calibration	Green	No errors.
-	Purple	Reagent unchecked and judgment is impossible.

The test list is a list of analysis tests registered for each group. The asterisk in **Test Name** indicates that advanced calibration is programmed for the test.

System Monitoring and Results

Monitor the Reagent Blank and Calibration

- 2 Select the sample type in **Type**. The system displays the current reagent blanks and calibration status as a list. A test that displays an asterisk indicates that advanced calibration is programmed for the test.
- 3 Select **All Tests** or **Tests with Error in Display**.
 - **All Tests**: Displays all the test data for the Group.
 - **Tests With Error**: Displays data for tests with an error in calibration or reagent blanks.
- 4 Select the cell under the Reagent Blank column or Calibration column of a test to view the RB History tab or Calibration History tab.
The most recent reagent blank or calibration data displays. Select the date on the x-axis of the graph to view the corresponding calibration data.
- 5 Select **RB Detail** to display and print the detailed reagent blank data for each test. Select **Calibration Detail** to display and print the detailed calibration data and charts for each test.
- 6 To view the individual status on multiple bottles, select **RB/CAL Selection** [F6]. The RB/CAL Selection dialog opens.

Figure 4.11 RB/CAL Selection Dialog

RB/CAL Selection									
Type	Serum								
Test Name	Seq.	R1(R1-1)		R2(R2-1)		R1-2		Reagent Blank	Calibration
		Lot No.	Bottle No.	Lot No.	Bottle No.	Lot No.	Bottle No.		
11.TP	1	7801	0570	7801	0581			Expired	Expired
18.CO2								No Data	No Data
15.AST	1	7589	2790	7589	2806			Passed RB	
8.BUN	1	8113	3593	8113	3611			Passed RB	Passed Calibration
9.GGT	1	7628	1491	7628	1508			Passed RB	
10.LDH	1	7582	1820	7582	1780			Passed RB	
12.ALP	1	7645	0141	7645	0206			Passed RB	
13.AMY	1	7545	1968					Passed RB	
13.AMY	2	8275	2330					Passed RB	
14.ALT	1	7617	0908	7617	0919			Passed RB	

- 7 Select the cell under the Reagent Blank column or Calibration column to view the RB Detail tab or Calibration Detail tab, where detailed information displays.
- 8 Select the **Status** tab to return to reagent blank and calibration status.
- 9 Select **Factor List** [F4].
The Factor List dialog opens. Factor A for tests where the interpolation formula for the calibration curve is the type $Y = AX + B$ is displayed.
- 10 After confirmation of the factor, select **Close**.
The Factor List dialog closes.

Review Reagent Blank and Calibration History

Review Reagent Blank History

- 1 Select **MENU > Calibration > Calibration Monitor > Status**. Select the Reagent Blank column of the test name to go to the RB History tab.

Figure 4.12 Calibration Monitor: RB History Tab

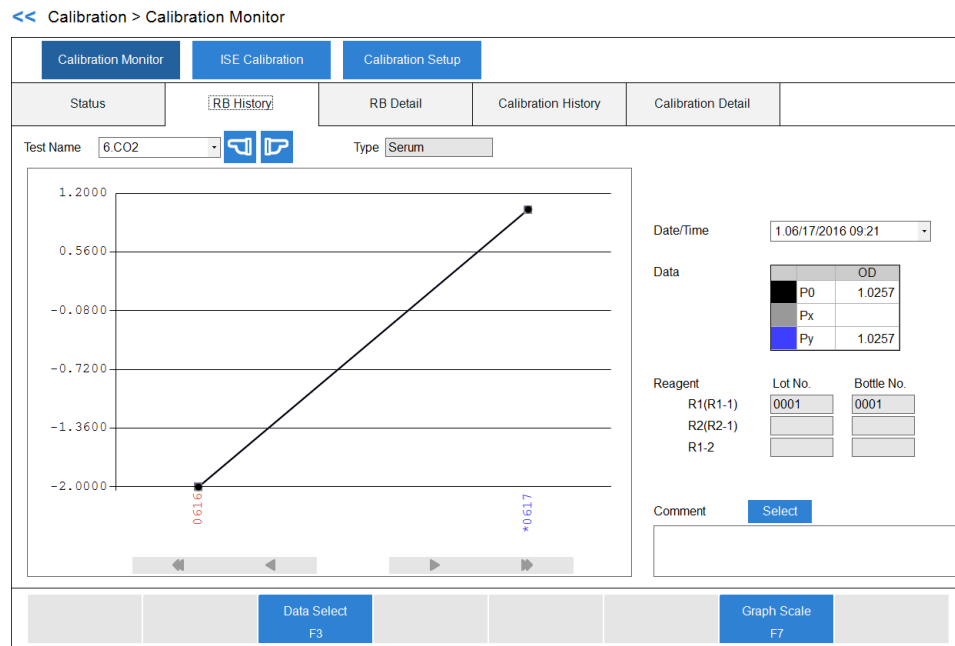

- P0: Measuring point 0.
- Px: The read point programmed in the Measuring Point-1 First field in the Test Volume and Methods: General tab (**Test Volume and Methods > General**).
- Py: The read point programmed in the Measuring Point-1 Last field in the Test Volume and Methods: General tab. When the Measuring Point-1 First field is programmed to 0, this field is blank (not accessible).

- 2 View the chart of the OD of the reagent blank.
The system saves a maximum of 100 points of data per sample type per test. The vertical line indicates a new lot number of reagent. The vertical line indicates a new lot number or new bottle number of reagent when you program **Advanced Calibration Interval (RB)** and **Interval (ACAL) to Bottle** in the Calibration setup: General tab (**CONFIG. > Calibration Setup > General**).

- 3 Select the test to display in **Test Name**.

Review Calibration History

- 1 Select **MENU > Calibration > Calibration Monitor > Status**. To go to the Calibration History tab, select the Calibration column of the test name.

System Monitoring and Results
 Monitor the Reagent Blank and Calibration

Figure 4.13 Calibration Monitor: Calibration History Tab

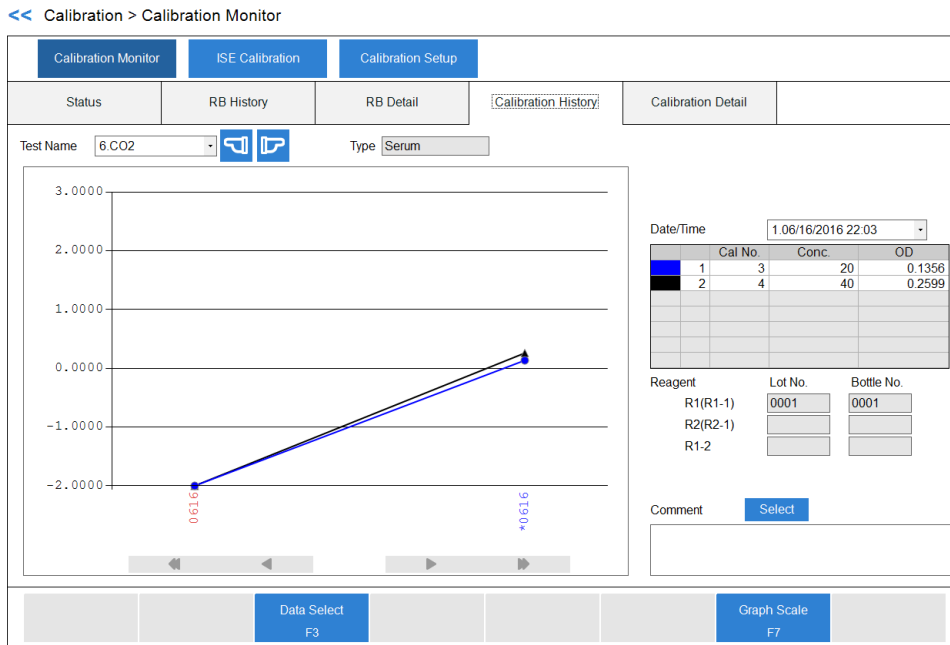

2 View the chart of the OD of the calibration.

The system saves a maximum of 100 points of data per sample type per test. The vertical line indicates a new lot number of reagent. The vertical line indicates a new lot number or new bottle number of reagent when you program **Yes for Operation, Bottle for Interval (RB)**, and **Bottle for Interval (ACAL)** in Advanced Calibration in the Calibration setup: General tab (**CONFIG. > Calibration setup > General**).

3 Select the test to display in **Test Name**.

Review Reagent Blank and Calibration Detailed Data

Review RB Detail

- 1** Select **MENU > Calibration > Calibration Monitor > Status**. To go to the RB Detail tab, select **RB/CAL Selection [F6]**, and then select the Reagent Blank column of the test name.

Figure 4.14 Calibration Monitor: RB Detail Tab

<< Calibration > Calibration Monitor

Calibration Monitor
ISE Calibration
Calibration Setup

Status
RB History
RB Detail
Calibration History
Calibration Detail

Test Name: Type:

Date/Time: Passed

Reagent	Lot No.	Bottle No.	Reagent Blank	P0	1.0257	Px		Py	1.0257
R1(R1-1)	<input type="text" value="0001"/>	<input type="text" value="0001"/>							
R2(R2-1)	<input type="text"/>	<input type="text"/>							
R1-2	<input type="text"/>	<input type="text"/>							

Sequence:

RB Expiration Date:

Method:

Wavelength: nm nm

Point-1:

Point-2:

	OD		OD		OD		OD
P0	1.0257	P7	1.0257	P14	1.0257	P21	1.0257
P1	1.0257	P8	1.0257	P15	1.0257	P22	1.0257
P2	1.0257	P9	1.0257	P16	1.0257	P23	1.0257
P3	1.0257	P10	1.0257	P17	1.0257	P24	1.0257
P4	1.0257	P11	1.0257	P18	1.0257	P25	1.0257
P5	1.0257	P12	1.0257	P19	1.0257	P26	1.0257
P6	1.0257	P13	1.0257	P20	1.0257	P27	1.0257

Comment Select

RB/CAL Selection F2
Data Select F3
Flags Contents F6
Print F8

2 View detailed reagent blank data information.

3 Select the test to display in **Test Name**.

Review Calibration Detail

1 Select **MENU > Calibration > Calibration Monitor > Status**. To go to the Calibration Detail tab, select **RB/CAL Selection [F6]**, and then select the Calibration column of the test name.

Figure 4.15 Calibration Monitor: Calibration Detail Tab

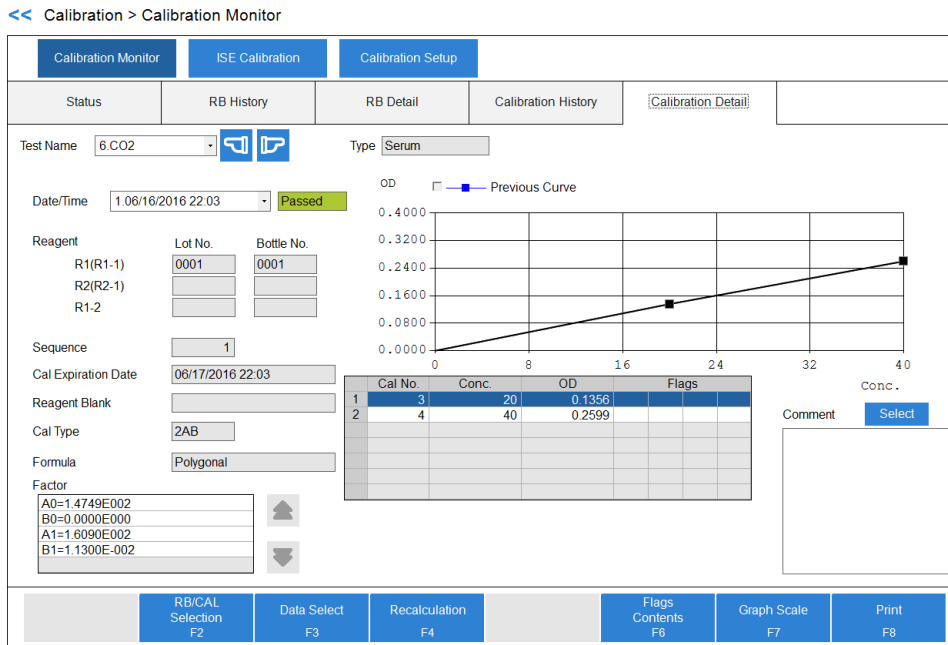

2 View detailed calibration data.

3 Select the test to display in **Test Name**.

Print Reagent Blank and Calibration Data

1 In the RB Detail tab or Calibration Detail tab, select **Print** [F8].

The system opens the Print dialog with options.

- **Recent/History:** Recent data or History (maximum of 100 points)
- **Sample Kind:** Reagent Blank and Calibration
- **RB Data Options:** P0-P27 or P0, Px, Py
- **Factor:** Without Factor or With Factor
- **Output Item:** Display Item or All Items (Serum, Urine, Other-1, Other-2, and Whole Blood)

2 Select **OK** to print.

Display Data History

Displaying data history and adding a comment are common features of the RB History, RB Detail, Calibration History, and Calibration Detail tabs. Changing the graph scale is a common feature of the RB History, Calibration History, and Calibration Detail tabs.

1 To display a history of the R1 and R2 lot numbers and bottle numbers, select **Data Select** [F3].

Figure 4.16 Data Select Dialog

Date	R1(R1-1)		R2(R2-1)		R1-2		Comment
	Lot No.	Bottle No.	Lot No.	Bottle No.	Lot No.	Bottle No.	
1.12/22/2015 12:35	7710	1280					Analysis

- 2 In the Date column, select the reagent blank data to display, then select **OK**.

 **Note**

You can also display reagent blank and calibration history data by selecting a date and time in **Date/Time** in the RB History tab or Calibration History tab, or by selecting the date on the x-axis of the graph.

Add a Comment

You can avoid having to retype common comments by selecting master comments, which are pre-programmed comments. Program master comments in the Comment Master screen (**CONFIG. > Comment Master**). For more information, refer to [Comment Master Screen](#).

You can add master comments to RB and calibration data.

Comments created in the RB History or RB Details tabs display in both tabs. Comments created in the Calibration History and Calibration Details tabs display in both tabs.

- 1 Select **Select**.

The system displays the Comment dialog.

Figure 4.17 Comment Dialog

No.	Comment
1	
2	
3	
4	
5	
6	
7	
8	
9	
10	
11	
12	
13	
14	
15	

System Monitoring and Results

Monitor QC

-
- 2 Select the comment to set.
-
- 3 Select **OK**.
The system closes the dialog, and displays the selected comment in **Comment** field.
Edit the comment if necessary.
-
- 4 If master comments are not programmed, enter a comment.
-

Change the Graph Scale

You can change the graph display size.

-
- 1 Select **Graph Scale** [F7].
The Graph Scale dialog displays.

Figure 4.18 Graph Scale Dialog

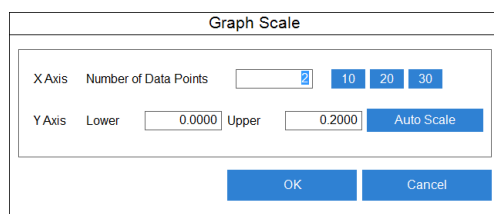

-
- 2 In **X Axis**, to specify the number of data points, select **10**, **20**, or **30**, or enter a number in **Number of Data Points**.
-
- 3 In **Y Axis**, set the lower limit value and upper limit value in **Lower** and **Upper**.
When you select **Auto Scale**, the system automatically sets the upper limit and lower limit values and displays the scale calculation.
-
- 4 Select **OK**.
The system redraws the graph with the set scale.
-

Monitor QC

The following are options for monitoring QC results:

- [Monitor the QC Using the Daily Variation Chart](#)
- [Monitor the QC Using the Day-to-Day Variation Chart](#)
- [Monitor the QC Using the Twin Plot Chart](#)

Monitor the QC Using the Daily Variation Chart

You can review QC results by plotting the individual QC points from one index or a range of indexes on a single chart. Always review the daily chart after performing daily QC analysis.

1 Select **QC > Chart > Main**.

The system displays the Main tab with the tests selected that performed quality controls in the current index for all sample kinds.

Figure 4.19 Chart: Main Tab

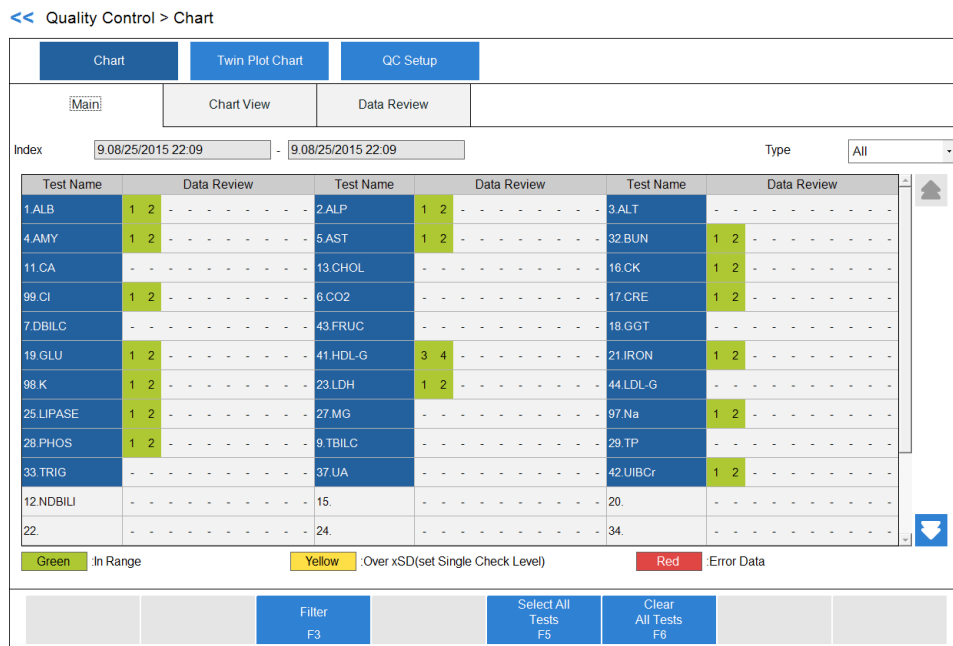

Table 4.6 Data Review Column Colors

Color	Description
Green	Normal data
Yellow	Data outside the range of the Single Check Level programmed in the QC Setup screen (CONFIG. > QC Setup)
Red	Error data (data not included in the QC statistical values)

2 To change the tests to display in the chart:

- To select by sample type, select the sample type from **Type**.
- To select the QC results in another index range, select **Filter** [F3].
- To select a specific test, select or clear individual test names.
- To clear all tests, select **Clear All Tests** [F6].
- To select all tests, select **Select All Tests** [F5].

3 Select **Chart View**.

The system displays either **Daily** [F7] or **Day to Day** [F7], defaulting to the previous selection made after selecting **Chart View**.

- To see individual QC points for the displayed test, select **Daily** [F7].
- To see an average of the QC points for the displayed test, select **Day to Day** [F7].

After selecting **Daily** [F7], the system displays the Daily - Chart View with the daily chart for all individual QC points for the displayed test. Change the display to other control material assigned to the test by selecting **Control Name**. The system does not plot results on the chart that exceed $\pm 3SD$ from the mean value.

Figure 4.20 Chart View Tab: Daily Chart

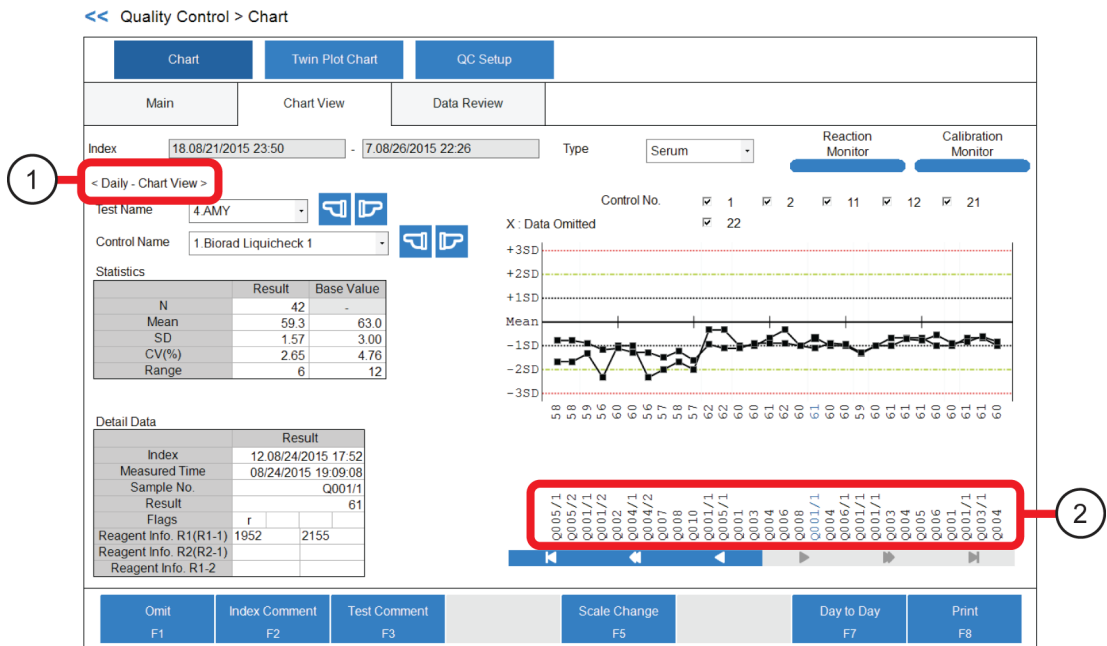

1. Daily - Chart View

2. Individual Control Sample No.

- **Test Name:** Select the test name to display the chart.
- **Type:** Select the sample type to display the chart.
- **Control Name:** Select a control to highlight the graph on the chart and to display the statistical results and the detailed data for the control.
- **Statistics:** The screen displays the statistical values for the control selected in **Control Name**.
- **Detail Data:** The screen displays the detailed data for the individual control sample number selected below the chart. The detailed data includes the index, measured time, sample number, result, flag, and reagent lot number and bottle number.
- **Scale Change [F5]:** When selected, you can specify the number of data points to display on the x-axis (10, 20, or 30). You cannot change the display of the y-axis.
- **Individual Control Sample No.:** Select an individual control sample No. below the chart to display the detailed data. A number from one to five displays after the '/' indicating the reagent bottle sequence number if QC analysis is performed on a test with multiple reagent bottles on-board.

Note

- Select **Reaction Monitor**.

The system displays the Reaction Monitor: General Tab with the displayed data in Daily Chart.

- To return to the Chart tab, select **<< icon**.
- Select **Calibration Monitor**.

The system displays the Calibration Monitor: Calibration History Tab for the displayed test in Daily Chart.

- To return to the Chart tab, select **<< icon**.

4 Optional: Select **Print** [F8].

The Print dialog displays.

- In **List Type**, select the list type options (**Statistics, Detail Data, Graph, and with Comments**) to print.
- In **Output Data**, select the output data to print (**Display Data or All Data**).
- Select **OK**.

Printing starts.

Monitor the QC Using the Day-to-Day Variation Chart

The day-to-day variation chart compares QC results by plotting multiple days of QC analysis on a chart that displays the variation. The system averages all QC points for a specific control within an index, then plots them on the day-to-day chart.

1 Select **QC > Chart > Main**.

The system displays the Main tab with the tests that performed quality controls in the current index for all sample kinds selected.

Figure 4.21 Chart: Main Tab

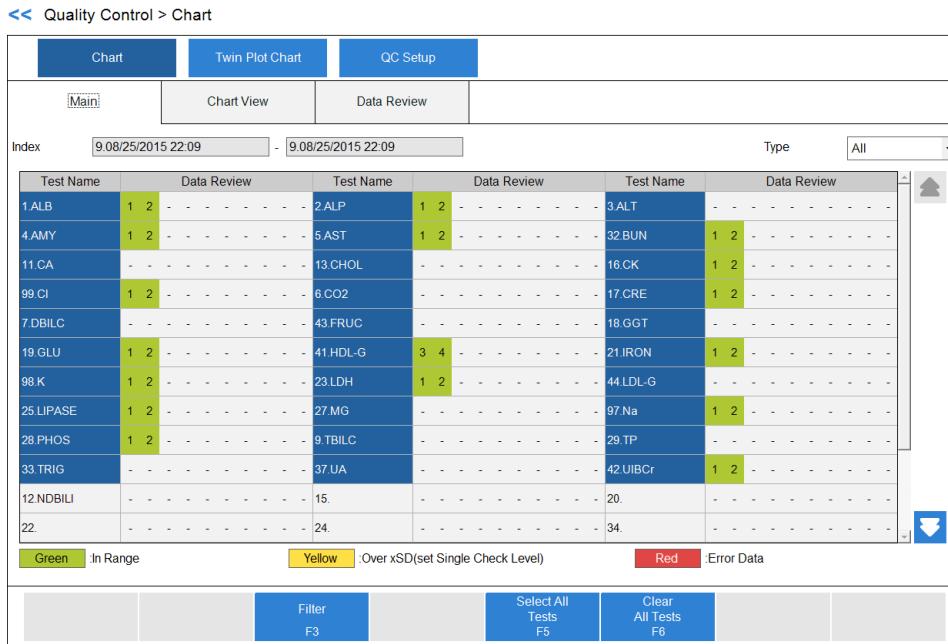

Table 4.7 Data Review Column Colors

Color	Description
Green	Normal data
Yellow	Data outside the range of the Single Check Level programmed in the QC Setup screen (CONFIG. > QC Setup)
Red	Error data (data not included in the QC statistical values)

2 To change the tests to display in the chart:

- To select by sample type, select the sample type from **Type**.
- To select the QC results in another index range, select **Filter** [F3].
- To select a specific test, select or clear individual test names.
- To clear all tests, select **Clear All Tests** [F6].
- To select all tests, select **Select All Tests** [F5].

3 Select **Chart View**.

The system displays either **Daily** [F7] or **Day to Day** [F7], defaulting to the previous selection made after selecting **Chart View**.

- To see individual QC points for the displayed test, select **Daily** [F7].
- To see an average of the QC points for the displayed test, select **Day to Day** [F7].

After selecting **Day to Day** [F7], the system displays the Day to Day - Chart View with an average of the QC points for the displayed test within the index. Change the display to other control material assigned to the test by selecting **Control Name**.

Figure 4.22 Chart Tab: Day to Day Chart

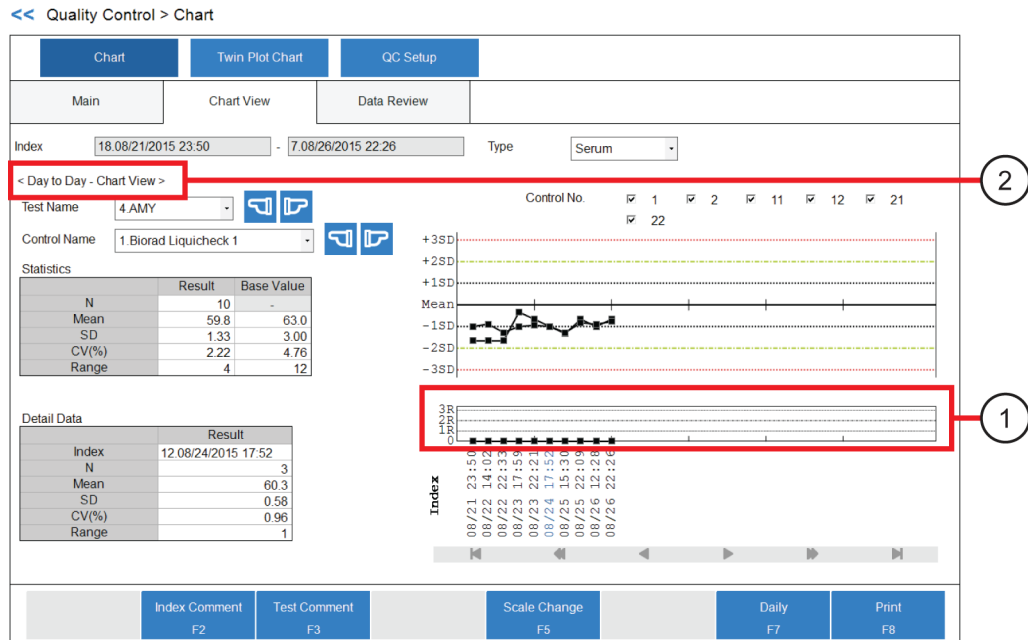

1. Range (R) Graph

2. Day to Day - Chart View

- **Test Name:** Select the test name to display the chart.
- **Type:** Select the sample type to display the chart.
- **Control Name:** Select a control to highlight the graph on the chart and to display the statistical results and the detailed data for the control.
- **Statistics:** The screen displays the statistical values for the control selected in **Control Name**.
- **Detail Data:** The screen displays the detailed data for the control selected in **Control Name** for the selected date and time on the x-axis of the chart.
- **Scale Change [F5]:** When selected, you can specify the number of data points to display on the x-axis (10, 20, or 30). You cannot change the display of the y-axis.
- **Range (R) Graph:** The difference in the range of the QC data for each index. The system determines the R value by the range programmed in the QC Setup screen. For example, for an R value of 12, then 1R on the graph has a value of 12 and 2R has a value of 24. The Range Graph is more effective for evaluating precision than accuracy.

4 Optional: Select **Print [F8]**. The Print dialog displays.

- In **List Type**, select the list type options (**Statistics**, **Detail Data**, **Graph**, and **with Comments**) to print.
- In **Output Data**, select the output data to print (**Display Data** or **All Data**).
- Select **OK**.

Printing starts.

Monitor the QC Using the Twin Plot Chart

Use twin plot analysis to determine whether the system caused a QC variation or a random error caused the variation. The system normally performs QC analysis using two control samples:

- A sample in the reference interval
- A sample in the pathological range

The twin plot function displays the first control sample on the x-axis of a 2-dimensional plot and the second control sample on the y-axis. Confirm that all points fall within the 2SD range in the center of the twin plot.

- 1 Select **QC > Twin Plot Chart > Test Select**.
- 2 In **Index**, select the start index and end index range to display.
- 3 Select the sample type in **Type**.
- 4 Select the tests to display.



Note

Select **Select All Tests** [F5] to select all tests. Select **Clear All Tests** [F6] to clear all tests.

- 5 Select **By Sample**.
The system displays QC data by sample number for the range of indexes selected.

Figure 4.23 Twin Plot Chart: By Sample Tab

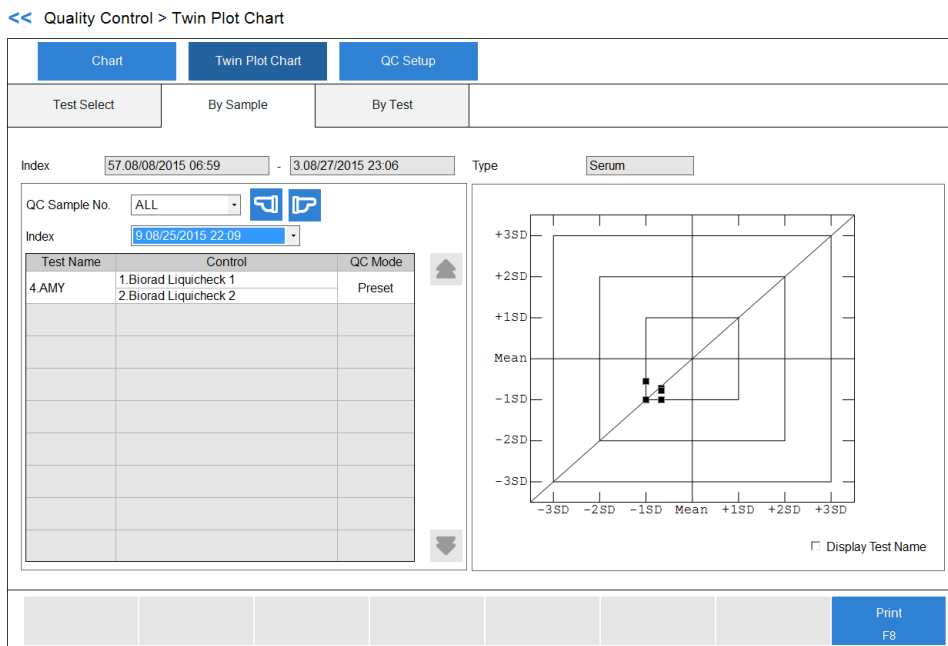

 **Note**

When the tests selected in the Test Select tab are displayed together, you can estimate the causes for fluctuations regarding temperature and calibrator more effortlessly.

6 Select **Display Test Name** to display test names on the chart.

When a test name is selected, the system displays the test name on the chart highlighted in red.

7 In **QC Sample No.**, select the control sample number to view.

 **Note**

When an abnormal condition occurs, refer to *DxC 700 AU Instructions for Use*.

8 Select **By Test**.

Figure 4.24 Twin Plot Chart: By Test Tab

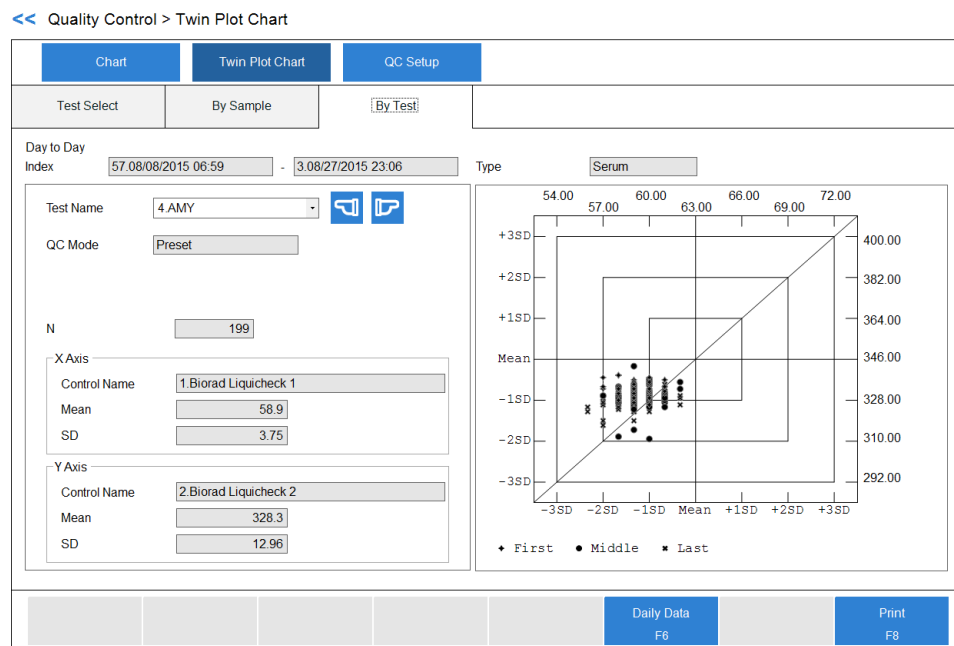

The system displays the tests selected in the Test Select tab for each test.

The system displays QC data chronologically, divided into three blocks to review high shifts or other errors.

9 To display the daily statistical results, select **Daily Data** [F6].

Add a QC Comment

You can avoid having to retype common comments by selecting master comments, which are pre-programmed comments. Program master comments in the Comment Master screen (**CONFIG. > Comment Master**). For more information, refer to [Comment Master Screen](#).

You can add comments to QC data.

You can add comments in the Chart View tab (**QC > Chart > Chart View**) or the Data Review tab (**QC > Chart > Data Review**).

An Index Comment adds a comment by the index title for all QC in the index. A Test Comment adds a comment for a specific test within the index.

Add an Index Comment

-
- 1 Select **QC > Chart > Chart View** or **QC > Chart > Data Review**.

 - 2 Select **Index Comment** [F2].
The system displays the Index Comment dialog.

Figure 4.25 Index Comment Dialog

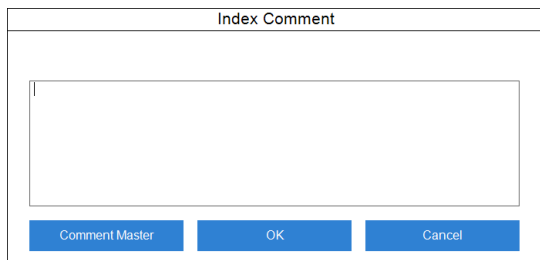

-
- 3 Enter a comment or select **Comment Master** to select the comment programmed in Comment Master screen (**CONFIG. > Comment Master**).

 - 4 Select **OK**.
The dialog closes.

 - 5 To view comments, select **Index Comment** [F2].
-

Add a Test Comment

-
- 1 Select **QC > Chart > Chart View** or **QC > Chart > Data Review**.

 - 2 Select **Test Comment** [F3].
The system displays the Test Comment dialog.

Figure 4.26 Test Comment Dialog

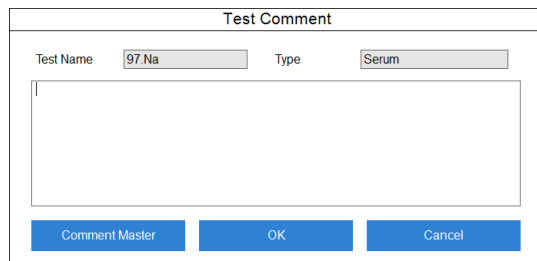

-
- 3** Enter a comment or select **Comment Master** to select the comment programmed in the Comment Master screen (**CONFIG. > Comment Master**).

 - 4** Select **OK**.
The dialog closes.

 - 5** To view comments, select **Test Comment** [F3].
-

Edit Quality Control Data

You can search for and edit analyzed QC data.

You can edit, omit, or add a comment by control sample number or test.



Caution

You can edit analyzed QC data. To prevent an erroneous diagnosis caused by numerous changes to the quality control data, edit according to your laboratory procedure.



Note

After editing QC analysis data results, confirm that the edited data falls within the cumulative period. If it falls within the cumulative period, the cumulative values must reflect the editing of the contents. Update the cumulative values. For more information, refer to [QC Setup Menu](#).

-
- 1** Select **QC > Chart > Data Review**.

Figure 4.27 Data Review Tab: by Sample Display

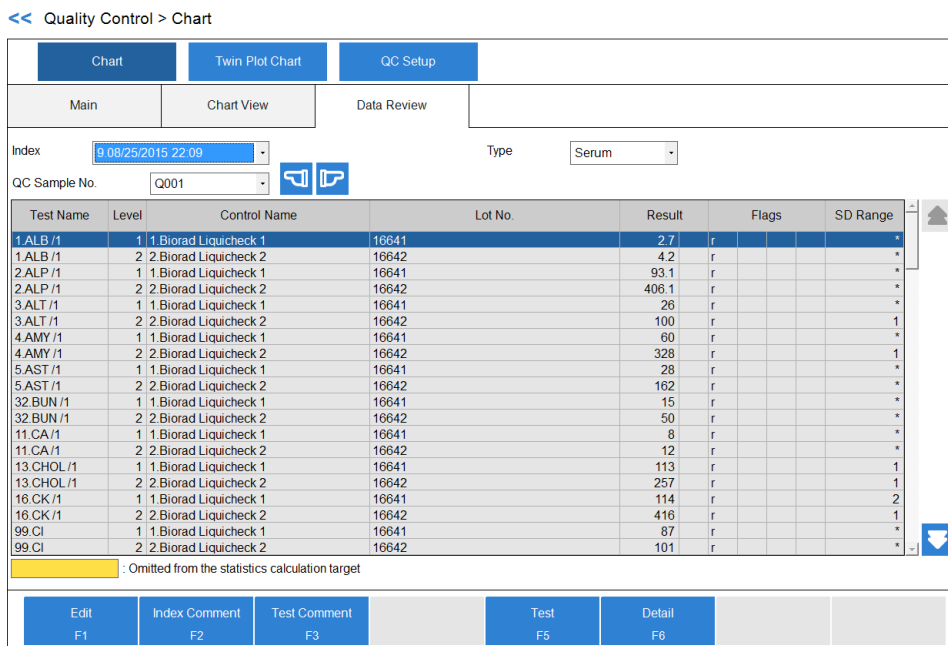

- 2 Select the index in **Index**.
- 3 In **Type**, select the sample type.
- 4 Select **Test** [F5] or **Sample** [F5] to alternate the display between by test or by sample.
- 5 Select **Edit** [F1].
- 6 To omit all of the data displayed on the screen from the statistical calculation, select **Omit** [F4].
- 7 To apply all of the data to the statistical calculation, select **Apply** [F5].
- 8 To edit an individual result, edit the result or flag on **Result** or **Flags**.
- 9 To omit the individual result from the statistical calculation, enter d in **Flags**.
- 10 To edit a comment, select **Index Comment** [F2] or **Test Comment** [F3].
- 11 Select **Save** [F1].

Sample Management

The system displays manually edited analysis data with an e flag. The system displays analysis data that has been edited with a correction formula with a c flag, indicating manual data correction.

The following are methods for editing analysis data:

- Edit Patient Sample Data
- Correct Patient Sample Data
- Recalculate Analysis Data Using a Previous Calibration Curve
- Send Data to Laboratory Information System



Edit only according to your laboratory procedures.

Edit Patient Sample Data

You can review and edit results and flags. If you edit a result or flag, the system attaches an e flag to the result.

1 Select RESULT > Sample Manager > Main.

The system displays a list of samples in the current index, selected (highlighted in blue).

Figure 4.28 Sample Manager: Main Tab

<< Results > Sample Manager

Sample Manager		Reaction Monitor	Data Statistics	Correlation Chart		
Main	By Patient Sample	By Patient Test				
Index	2.10/19/2015 11:06	-	2.10/19/2015 11:06			
<input type="button" value="Select All Samples"/>	<input type="button" value="Clear All Samples"/>		<input type="checkbox"/> Abnormal	<input type="checkbox"/> Rerun Data		
No. [*]	Sample No.	Cup Position	Sample ID	Run Date/Time	Status	
39	0029	0072-04	ODC0014	10/19/2015 13:54:03	Done	
40	0030	0072-05	ODC0014	10/19/2015 13:54:07	Done	
41	0031	0072-06	ODC0014	10/19/2015 13:54:12	Done	
42	0032	0072-07	ODC0014	10/19/2015 13:54:16	Done	
43	0033	0072-08	ODC0014	10/19/2015 13:54:21	Done	
44	0034	0072-09	ODC0014	10/19/2015 13:54:26	Done	
45	0035	0072-10	ODC0014	10/19/2015 13:54:30	Done	
46	0036	0056-01	ODC0015	10/19/2015 13:54:35	Done	
47	0037	0056-02	ODC0015	10/19/2015 13:54:39	Done	
48	0038	0056-03	ODC0015	10/19/2015 13:54:44	Done	
49	0039	0056-04	ODC0015	10/19/2015 13:54:48	Done	
50	0040	0056-05	ODC0015	10/19/2015 13:54:53	Done	
51	0041	0056-06	ODC0015	10/19/2015 13:54:57	Done	
52	0042	0056-07	ODC0015	10/19/2015 13:55:02	Done	
53	0043	0056-08	ODC0015	10/19/2015 13:55:06	Done	
54	0044	0056-09	ODC0015	10/19/2015 13:55:11	Done	
55	0045	0056-10	ODC0015	10/19/2015 13:55:15	Done	

<input type="button" value="Copy to Disk"/>	<input type="button" value="Find"/>	<input type="button" value="External Memory Remove"/>	<input type="button" value="Remove External Memory"/>	<input type="button" value="Data Correction"/>	<input type="button" value="Send to LIS"/>	<input type="button" value="Print"/>
F2	F3	F4	F4	F6	F7	F8

Table 4.8 Main Tab Description

Option	Description
Select All Samples	Select all samples displayed in the list.
Clear All Samples	Clear the selection of all samples displayed in the list.
Copy to Disk [F2]	Copy the results to external memory device or CD-R.
Find [F3]	Search for data according to the following parameters: Index Range, Sample Number, Sample ID, Data Not Yet Transferred to LIS, Data Not Yet Printed, or Patient Information.

Table 4.8 Main Tab Description (Continued)

Option	Description
Remove External Memory [F4]	Remove the external memory media safely.
Recalculate Data [F5]	Recalculate results using a previous calibration factor.
Data Correction [F6]	Correction by A and B of the correction coefficient $AX + B$ is possible by test and by sample type.
Send to LIS [F7]	Send the patient sample results and RB, calibration, and QC results to an LIS.
Print [F8]	Print the selected samples in a list format.

- If necessary, select **Find** [F3] to search for data according to the following parameters: Index Range, Sample Number, Sample ID, Data Not Yet Transferred to LIS, Data Not Yet Printed, or Patient Information.
- Select **OK** to update the contents of the Main tab.
The system displays a list with the samples found using the search criteria.
- Select **By Patient Sample** or **By Patient Test**.
The system displays the search results.

Figure 4.29 Sample Manager: By Patient Sample Tab

<< Results > Sample Manager

Sample Manager
Reaction Monitor
Data Statistics
Correlation Chart

Main
By Patient Sample
By Patient Test

Index Reaction Monitor

Sample No. Type Sample ID

Sex Age Years Months

Test Name	Result	Flags	Test Name	Result	Flags
2.ALP	62.0	r	3.ALT	15	r
5.AST	14	r	32.BUN	21	r
11.CA	9	r	13.CHOL	138	r
99.Cl	103	r	6.CO2	27	r
17.CRE	1	r	19.GLU	119	r
41.HDL-G	37	r	98.K	5	r
27.MG	2	r	97.Na	141	r
28.PHOS	4	r	33.TRIG	119	r
37.UA	6	r	Lipemia	N	r
Icterus	N		Hemolysis	N	
90.LDL-X	77	r			

Edit
F1
Overwritten by Rerun
F5
Detail
F6

You can review and edit results and flags. If you edit a result or flag, the system attaches an e flag to the result.

- If the data indicates problems, select **Reaction Monitor** to display the Reaction Monitor screen and review specific information regarding the sample. Select **Back** in the Reaction Monitor screen to return to the Sample Manager screen.

- 6 Select **Edit** [F1].
You can edit results or flags.
- 7 In the By Patient Sample tab, select the test name for which to perform edits. In the By Patient Test tab, select the sample number for which to perform edits.
- 8 Select **Detail** [F6] to view the sample dilution rate, reagent lot number, and reagent bottle number.
- 9 Edit the desired result or flags.
- 10 Select **Save** [F1] to save the edited data.

Correct Patient Sample Data

The system uses the correction formula $Y = AX + B$ to correct the data for the selected samples for a test or for all tests.

Y Data after correction

X Data before correction

A, B An optional correction factor (9 digits, including sign and decimal point)

- 1 Select **RESULT > Sample Manager > Main**.

The system displays a list of samples in the current index, selected (highlighted in blue).

Figure 4.30 Sample Manager: Main Tab

<< Results > Sample Manager

Sample Manager
Reaction Monitor
Data Statistics
Correlation Chart

Main
By Patient Sample
By Patient Test

Index
2.10/19/2015 11:06
-
2.10/19/2015 11:06

Select All Samples
Clear All Samples
 Abnormal
 Rerun Data

No.[*]	Sample No.	Cup Position	Sample ID	Run Date/Time	Status
39	0029	0072-04	ODC0014	10/19/2015 13:54:03	Done
40	0030	0072-05	ODC0014	10/19/2015 13:54:07	Done
41	0031	0072-06	ODC0014	10/19/2015 13:54:12	Done
42	0032	0072-07	ODC0014	10/19/2015 13:54:16	Done
43	0033	0072-08	ODC0014	10/19/2015 13:54:21	Done
44	0034	0072-09	ODC0014	10/19/2015 13:54:26	Done
45	0035	0072-10	ODC0014	10/19/2015 13:54:30	Done
46	0036	0056-01	ODC0015	10/19/2015 13:54:35	Done
47	0037	0056-02	ODC0015	10/19/2015 13:54:39	Done
48	0038	0056-03	ODC0015	10/19/2015 13:54:44	Done
49	0039	0056-04	ODC0015	10/19/2015 13:54:48	Done
50	0040	0056-05	ODC0015	10/19/2015 13:54:53	Done
51	0041	0056-06	ODC0015	10/19/2015 13:54:57	Done
52	0042	0056-07	ODC0015	10/19/2015 13:55:02	Done
53	0043	0056-08	ODC0015	10/19/2015 13:55:06	Done
54	0044	0056-09	ODC0015	10/19/2015 13:55:11	Done
55	0045	0056-10	ODC0015	10/19/2015 13:55:15	Done

Copy to Disk
F2
Find
F3
External Memory
Remove
F4
Remove
External Memory
F4
Data
Correction
F6
Send to LIS
F7
Print
F8

The screen displays the current index data.

- 2 Select **Find** [F3] to search for data according to the following parameters: Index Range, Sample Number(s), Sample ID, Data Not Yet Transferred to LIS, Data Not Yet Printed, or Patient Information.

Figure 4.31 Find Dialog: Patient Tab

Find

Index: 9/08/25/2015 22:09 - 9/08/25/2015 22:09

Search the designated sample Search all patient samples Data Not Transferred to LIS Data Not Printed

Search by Sample ID * -

Patient RB/Cal/QC

Sample Kind	Search by Sample No.			QC/Cal. No.	Search by Control / Calibrator ID
Calibration	A001	-	A004	*	*
QC	Q001	-	Q006	*	*
RB	R001	-	R004	*	*

Data Replicates Search only the data measured by Replicates.

Search by Patient Info. OK Cancel

- 3 Select **RB/Cal/QC**. Clear **RB, Cal, and QC**.

Figure 4.32 Find Dialog

Find

Index: 9/08/25/2015 22:09 - 9/08/25/2015 22:09

Search the designated sample Search all patient samples Data Not Transferred to LIS Data Not Printed

Search by Sample ID * -

Patient **RB/Cal/QC**

Sample Kind	Search by Sample No.			QC/Cal. No.	Search by Control / Calibrator ID
Calibration	A001	-	A004	*	*
QC	Q001	-	Q006	*	*
RB	R001	-	R004	*	*

Data Replicates Search only the data measured by Replicates.

Search by Patient Info. OK Cancel

- 4 Select **OK**.
The system displays a list with the samples found using the search criteria.
- 5 Select **Data Correction** [F6].
The system displays the Data Correction dialog.

Figure 4.33 Data Correction Dialog

The dialog box is titled "Data Correction". It contains a "Test Name" dropdown menu with "All" selected. Below the menu are two blue buttons: "Correction" and "Cancel".

- 6 Select the test to correct or **All** in **Test Name**, and then select **Correction**.
When you select a specific test, the dialog to enter factors A and B displays.

Figure 4.34 Data Correction Dialog (One Test Selected)

The dialog box is titled "Data Correction". It contains a prompt "Execute Correction?". Below the prompt are two input fields: "Factor A" with a cursor and "Factor B" with the value "0". At the bottom are two blue buttons: "OK" and "Cancel".

When you select **All**, the dialog for programming the factors A and B for all tests displays.

Figure 4.35 Data Correction Dialog (All Tests Selected)

The dialog box is titled "Data Correction". It contains a prompt "Execute Correction?" and a checkbox "Print List". Below is a table with columns for Test Name, Serum (Factor A, Factor B), Urine (Factor A, Factor B), Other-1 (Factor A, Factor B), Other-2 (Factor A, Factor B), and Whole Blood (Factor A, Factor B). The table lists 20 tests with their respective factor values. At the bottom are two blue buttons: "OK" and "Cancel".

Test Name	Serum		Urine		Other-1		Other-2		Whole Blood	
	Factor A	Factor B	Factor A	Factor B	Factor A	Factor B	Factor A	Factor B	Factor A	Factor B
1 ALB	1	0	1	0	1	0	1	0	1	0
2 ALP	1	0	1	0	1	0	1	0	1	0
3 ALT	1	0	1	0	1	0	1	0	1	0
4 AMY	1	0	1	0	1	0	1	0	1	0
5 AST	1	0	1	0	1	0	1	0	1	0
6 CO2	1	0	1	0	1	0	1	0	1	0
7 DBILC	1	0	1	0	1	0	1	0	1	0
8 DBB										
9 TBILC	1	0	1	0	1	0	1	0	1	0
10 TBB										
11 CA	1	0	1	0	1	0	1	0	1	0
12 NDBILI	1	0	1	0	1	0	1	0	1	0
13 CHOL	1	0	1	0	1	0	1	0	1	0
14 AMMON	1	0	1	0	1	0	1	0	1	0
15	1	0	1	0	1	0	1	0	1	0
16 CK	1	0	1	0	1	0	1	0	1	0
17 CRE	1	0	1	0	1	0	1	0	1	0
18 GGT	1	0	1	0	1	0	1	0	1	0
19 GLU	1	0	1	0	1	0	1	0	1	0
20	1	0	1	0	1	0	1	0	1	0

Select **Print List** to print the factor list.

- 7 Enter values for factors A and B and select **OK**.
The Data Correction dialog displays with the message **Operating: Please wait.**

When the correction completes, a message displays with the last sample number corrected.

- 8 Select **OK**.

System Monitoring and Results

Sample Management

The dialog closes and the Main tab displays. The system attaches a c flag to any corrected result.

Recalculate Analysis Data Using a Previous Calibration Curve

- 1 Select **Result > Sample Manager > Main**.

The system displays a list of samples in the current index, selected (highlighted in blue).

Figure 4.36 Sample Manager: Main Tab

<< Results > Sample Manager

Sample Manager Reaction Monitor Data Statistics Correlation Chart

Main By Patient Sample By Patient Test

Index 2.10/19/2015 11:06 - 2.10/19/2015 11:06

Select All Samples Clear All Samples Abnormal Rerun Data

No [N]	Sample No.	Cup Position	Sample ID	Run Date/Time	Status	
39	0029	0072-04	ODC0014	10/19/2015 13:54:03	Done	
40	0030	0072-05	ODC0014	10/19/2015 13:54:07	Done	
41	0031	0072-06	ODC0014	10/19/2015 13:54:12	Done	
42	0032	0072-07	ODC0014	10/19/2015 13:54:16	Done	
43	0033	0072-08	ODC0014	10/19/2015 13:54:21	Done	
44	0034	0072-09	ODC0014	10/19/2015 13:54:26	Done	
45	0035	0072-10	ODC0014	10/19/2015 13:54:30	Done	
46	0036	0056-01	ODC0015	10/19/2015 13:54:35	Done	
47	0037	0056-02	ODC0015	10/19/2015 13:54:39	Done	
48	0038	0056-03	ODC0015	10/19/2015 13:54:44	Done	
49	0039	0056-04	ODC0015	10/19/2015 13:54:48	Done	
50	0040	0056-05	ODC0015	10/19/2015 13:54:53	Done	
51	0041	0056-06	ODC0015	10/19/2015 13:54:57	Done	
52	0042	0056-07	ODC0015	10/19/2015 13:55:02	Done	
53	0043	0056-08	ODC0015	10/19/2015 13:55:06	Done	
54	0044	0056-09	ODC0015	10/19/2015 13:55:11	Done	
55	0045	0056-10	ODC0015	10/19/2015 13:55:15	Done	

Copy to Disk F2 Find F3 External Memory Remove F4 Remove External Memory F4 Data Correction F6 Send to LIS F7 Print F8

- 2 Select **Find [F3]** to search for data according to the following parameters: Index Range, Sample Number, Sample ID, Data Not Yet Transferred to LIS, Data Not Yet Printed, or Patient Information.

- 3 Select **RB/Cal/QC**. Clear **RB**, **Cal**, and **QC**.

- 4 Select **OK**.

The system displays a list of the samples found using the search criteria.

- 5 Select **Recalculate Data [F5]**.

The Recalculate Data dialog displays.

Figure 4.37 Recalculate Data Dialog

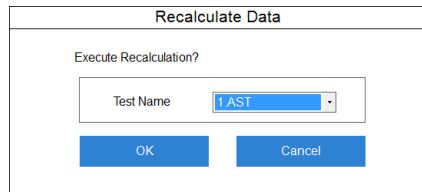

6 Select the test to recalculate in **Test Name**.

7 Select **OK**.

When the recalculation completes, a message displays with the last sample number involved in the recalculation. If the test is not performed on any samples selected using the search criteria, a dialog displays **Data Not Found**. The system does not attach a flag to the recalculated data.

Send Data to Laboratory Information System

Online transfer is possible if you select **Batch** or **Realtime** in **Analysis Results Transfer Mode** in the Online: Setup tab (**CONFIG. > Online > Setup**). For more information, refer to [Online Menu](#).

1 Select **Result > Sample Manager > Main**.

The system displays a list of samples in the current index, selected (highlighted in blue).

Figure 4.38 Sample Manager: Main Tab

<< Results > Sample Manager

Sample Manager
Reaction Monitor
Data Statistics
Correlation Chart

Main
By Patient Sample
By Patient Test

Index
2.10/19/2015 11:06
-
2.10/19/2015 11:06

Select All Samples
Clear All Samples
 Abnormal
 Rerun Data

No. [1]	Sample No.	Cup Position	Sample ID	Run Date/Time	Status
39	0029	0072-04	ODC0014	10/19/2015 13:54:03	Done
40	0030	0072-05	ODC0014	10/19/2015 13:54:07	Done
41	0031	0072-06	ODC0014	10/19/2015 13:54:12	Done
42	0032	0072-07	ODC0014	10/19/2015 13:54:16	Done
43	0033	0072-08	ODC0014	10/19/2015 13:54:21	Done
44	0034	0072-09	ODC0014	10/19/2015 13:54:26	Done
45	0035	0072-10	ODC0014	10/19/2015 13:54:30	Done
46	0036	0056-01	ODC0015	10/19/2015 13:54:35	Done
47	0037	0056-02	ODC0015	10/19/2015 13:54:39	Done
48	0038	0056-03	ODC0015	10/19/2015 13:54:44	Done
49	0039	0056-04	ODC0015	10/19/2015 13:54:48	Done
50	0040	0056-05	ODC0015	10/19/2015 13:54:53	Done
51	0041	0056-06	ODC0015	10/19/2015 13:54:57	Done
52	0042	0056-07	ODC0015	10/19/2015 13:55:02	Done
53	0043	0056-08	ODC0015	10/19/2015 13:55:06	Done
54	0044	0056-09	ODC0015	10/19/2015 13:55:11	Done
55	0045	0056-10	ODC0015	10/19/2015 13:55:15	Done

Copy to Disk
F2
Find
F3
External Memory
Remove
F4
Remove
External Memory
F4
Data
Correction
F6
Send to LIS
F7
Print
F8

System Monitoring and Results

Calculate Data Statistics

- 2 To search for data according to the following parameters: Index Range, Sample Number, Sample ID, Data Not Yet Transferred to LIS, Data Not Yet Printed, or Patient Information:
 - a. Select **Find** [F3].
 - b. Select **RB/Cal/QC** to search the reagent blank, calibration, and quality control results to send to LIS.
 - c. Select **OK**.
- 3 Select **Send to LIS** [F7].
The Online Transfer dialog displays.
- 4 Select **OK**.
The system transfers the data. Select **Stop Sending to LIS** [F7] to stop the transfer.

Calculate Data Statistics

The system displays statistical values of analyzed patient sample results with graphs and numerical data, providing easy-to-understand views, such as variations in results and changes in the same sample.

View Data Statistics

Review key statistics of sample results for a specified range of indexes.

To select samples to use to generate sample statistics:

- 1 Select **RESULT > Sample Manager > Data Statistics > Main**.

Figure 4.39 Data Statistics: Main Tab

Sample Kind	Search by Sample No.	Search by Sample ID
<input checked="" type="checkbox"/> Routine	0001 - 0001 * - * *	
<input type="checkbox"/> Emergency	- - * - * *	
<input type="checkbox"/> STAT	- - * - * *	

- 2 Select the index range in **Index**.
- 3 Select **Search all samples** or **Search the designated sample**.
 - If you select **Search all samples**, and you search the result with a specific sample ID, enter the sample ID in **Search by Sample ID**.
 - If you select **Search the designated sample**, set the search conditions in the tab.
 1. Select the sample kind to search in **Sample Kind**.
 2. Enter a specific sample number or sample ID to search as required.

The Search by Sample No. and Search by Sample ID fields default to search all (indicated by the *) sample numbers and ID numbers.

 3. Select the sample type to search in **Type**.
- 4 To use patient demographic information to search the data, select **Search by Patient Info.** [F5].
- 5 Select the search condition in the dialog, then select **OK**.
- 6 Select **Statistics** to display the data statistics in the Statistics tab.

Figure 4.40 Data Statistics: Statistics Tab

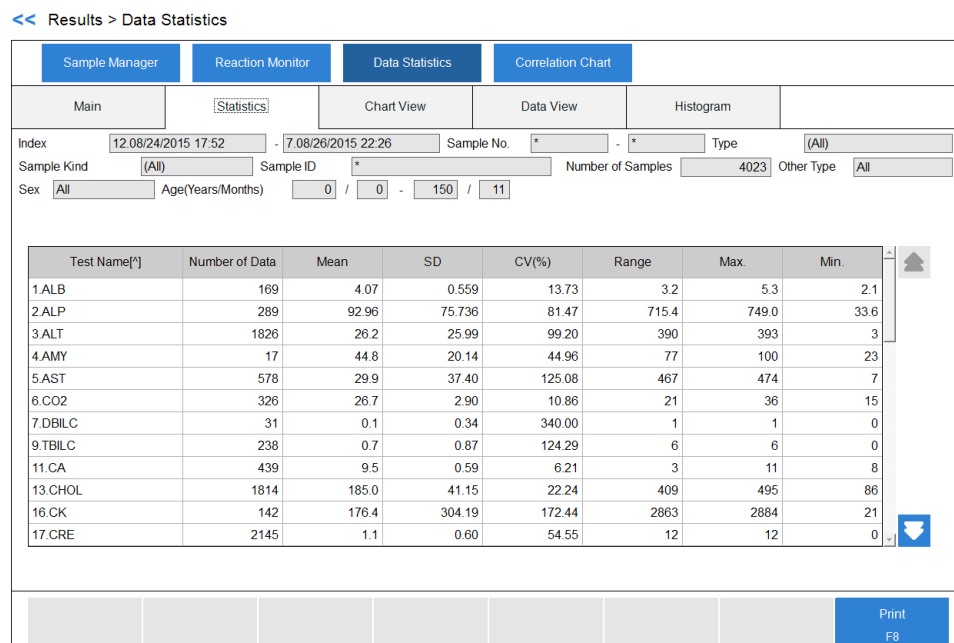

The data statistics include the number of data points, mean, SD, CV (%), range, and maximum and minimum results.

- 7 Select **Test Name** to display tests in test number order from 1 to 120, **Number of Data** to display tests from the highest to lowest number of data points, and **CV(%)** to display tests from the highest to lowest CV.

- 8 Select up to 12 tests to display data statistics for in the Chart View, Data View, or Histogram tabs.
- 9 Select **Chart View** to display data statistics and a graph.

Figure 4.41 Data Statistics: Chart View Tab

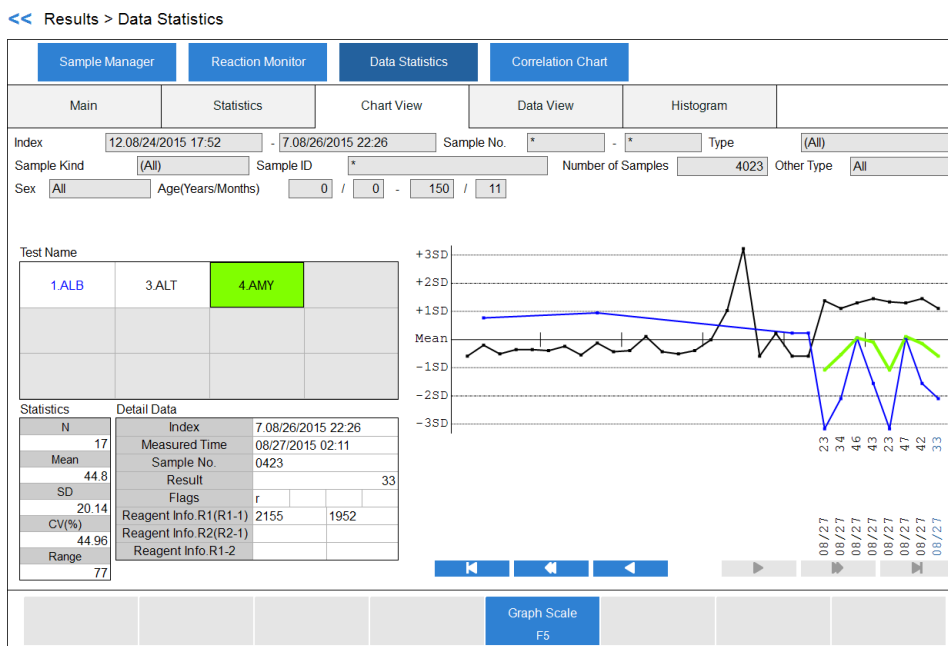

- 10 Select a test in **Test Name** to display the statistical information for that test in the **Statistics** section. Select a specific date, time, result, or sample number displayed on the X axis of the graph to display the information in the **Detail Data** section. The selected test displays with a thick line on the graph.
- 11 To change the graph display parameters, select **Graph Scale** [F5]. The Graph Scale dialog displays.

Figure 4.42 Graph Scale Dialog

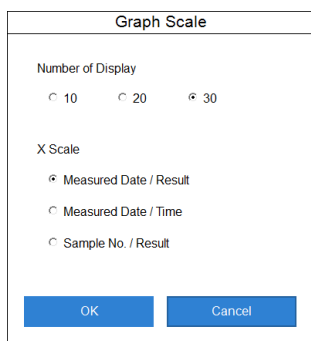

- 12 Select a number in **Number of Display** and an option in **X Scale** option, then **OK**. The graph display changes.

- 13** Select **Data View** to display the sample numbers, measure times, and results for the tests selected in the Statistics tab.

Figure 4.43 Data Statistics: Data View Tab

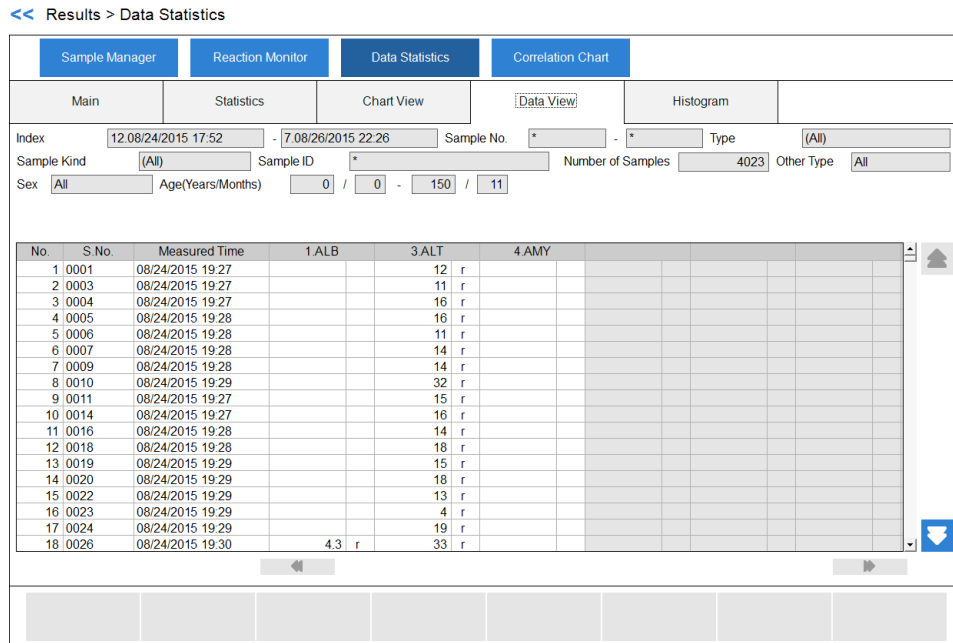

View data corresponding to 10,000 samples using the up or down scroll button.

Change the test display using the left or right scroll button.

- 14** Select **Histogram** to display test data statistics and a bar graph of the data.

Figure 4.44 Data Statistics: Histogram Tab

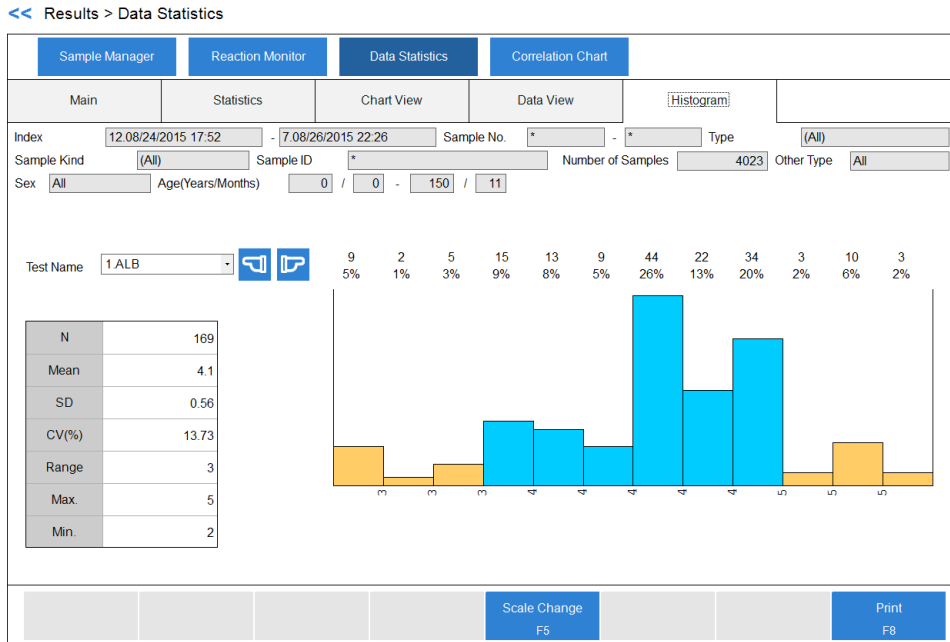

The system displays data within the range of the mean +/- 1 SD with a blue bar. The system displays data outside of the mean +/- 1 SD with an orange bar.

15 Select the test name in **Test Name**.

16 Select **Scale Change** [F5] to change the display range of the histogram.

Figure 4.45 Scale Change Dialog

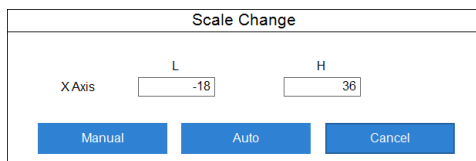

- a. Select **Auto** to display the entire range of results.
- b. Enter the lowest result and highest result to display in **X-Axis**, then select **Manual**.

Create a Correlation Chart

The Correlation Chart allows a comparison of two tests of the same samples within a specified index range.

This function calculates how well two tests correlate using different parameters.

To create a correlation chart, take the following steps:

- 1 Select **RESULT > Sample Manager > Correlation Chart > Main**.

Figure 4.46 Correlation Chart: Main Tab

- 2 Select the index range in **Index**.
- 3 Select the respective test name in **X Axis Test Name** and **Y Axis Test Name**.
- 4 Select **Search all samples** or **Search the designated sample**.
 - If you select **Search all samples**, and you search the result with a specific sample ID, enter the sample ID in **Search by Sample ID**.
 - If you select **Search the designated sample**, set the search conditions in the tab.
 1. Select the sample kind to search in **Sample Kind**.
 2. Enter a specific sample number or sample ID to search as required.

The Search by Sample No. and Search by Sample ID fields default to search all (indicated by the *) sample numbers and ID numbers.
 3. Select the sample type to search in **Type**.
- 5 To use patient demographic information to search the data, select **Search by Patient Info. [F5]**.
Enter information and then select **OK**.
- 6 To exclude data from the correlation chart, select **Data View**.

System Monitoring and Results

Calculate Data Statistics

Figure 4.47 Correlation Chart: Data View Tab

<< Results > Correlation Chart

Sample Manager
Reaction Monitor
Data Statistics
Correlation Chart

Main
Data View
Chart View

Index - Sample No. * - * Type *

Sample Kind * Sample ID * Number of Samples Other Type

Sex Age(Years/Months) / - /

No.	S.No.	Measured Time	X Axis 1 ALB	Y Axis 2 ALP
1	0026	08/24/2015 19:30	4.3 r	72.4 r
2	0161	08/24/2015 19:41	3.6 r	79.5 r
3	0162	08/24/2015 19:41	3.9 r	54.9 r
4	0247	08/24/2015 19:51	4.2 r	51.4 r
5	0280	08/24/2015 19:55	3.9 r	46.7 r
6	0310	08/24/2015 20:26	4.1 r	83.9 r
7	0562	08/24/2015 21:00	4.2 r	80.2 r
8	0659	08/24/2015 21:09	4.1 r	108.8 r
9	0649	08/24/2015 21:09	3.0 r	53.5 r
10	0661	08/24/2015 21:10	3.6 r	68.3 r
11	0650	08/24/2015 21:10	4.0 r	36.1 r
12	0666	08/24/2015 21:11	4.2 r	50.3 r
13	0669	08/24/2015 21:12	3.8 r	106.7 r
14	0693	08/24/2015 21:15	4.2 r	79.3 r
15	0696	08/24/2015 21:16	4.3 r	113.2 r
16	0709	08/24/2015 21:17	3.4 r	109.2 r
17	0718	08/24/2015 21:20	4.6 r	78.6 r
18	0729	08/24/2015 21:20	4.3 r	151.5 r

: Deselected from Chart View

Select / Deselect
F5

View data corresponding to 10,000 samples using the up or down scroll button.

- 7** Select the item to exclude.
- 8** Select **Select/Clear** [F5].
 The color of the item row changes, and the system deletes the item from the Chart View tab. If you select **Select/Clear** [F5] again, the system restores the item. The background color of the excluded sample changes to pink.
- 9** Select **Chart View** to display the correlation chart.

Figure 4.48 Correlation Chart: Chart View Tab

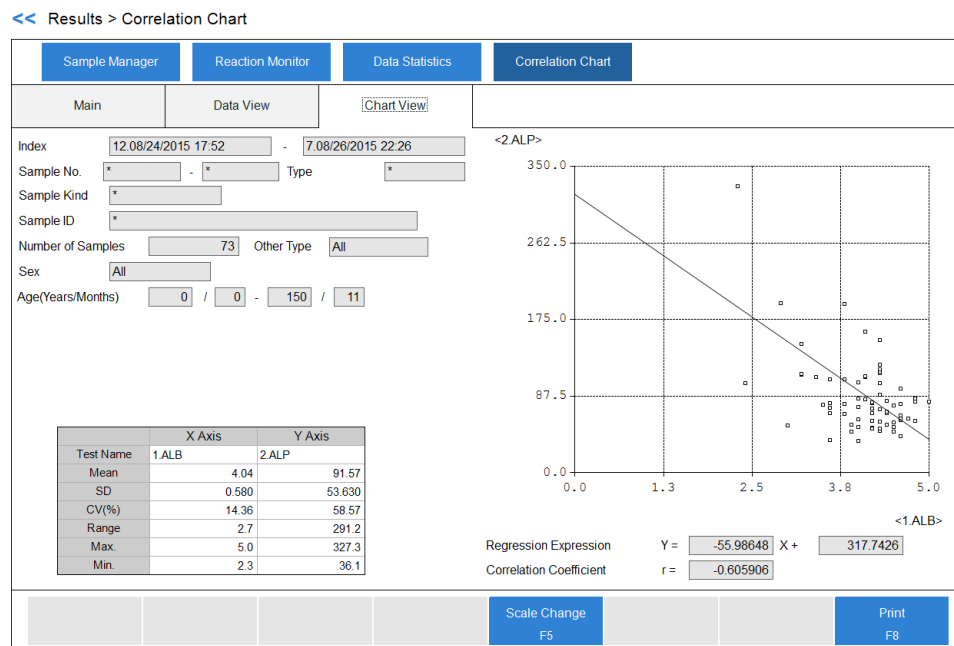

10 To change the display size of the correlation chart, select **Scale Change** [F5].

Figure 4.49 Scale Change Dialog

Scale Change

X Axis L: 0 H: 5

Y Axis L: 0 H: 400

Manual Auto Cancel

- Select **Auto** for the correlation chart to display the maximum range of all the data.
- Enter the lower limits and upper limits in **X Axis** and **Y Axis**.
- Select **Manual** to display the correlation chart with the defined limits.

11 To print the statistics and correlation chart, select **Print** [F8].
The Print Start dialog displays. Select **OK**.

Save or Load Parameters

The system can save or load parameters to a backup folder on the hard drive or external media. If you make programming changes, Beckman Coulter recommends saving parameters or following your laboratory procedure.

If you have multiple DxC 700 AUs in the laboratory, Beckman Coulter recommends saving the parameter files for each DxC 700 AU on separate external media.

1 Select **MAINT. > File Management.**

Figure 4.50 File Management Screen

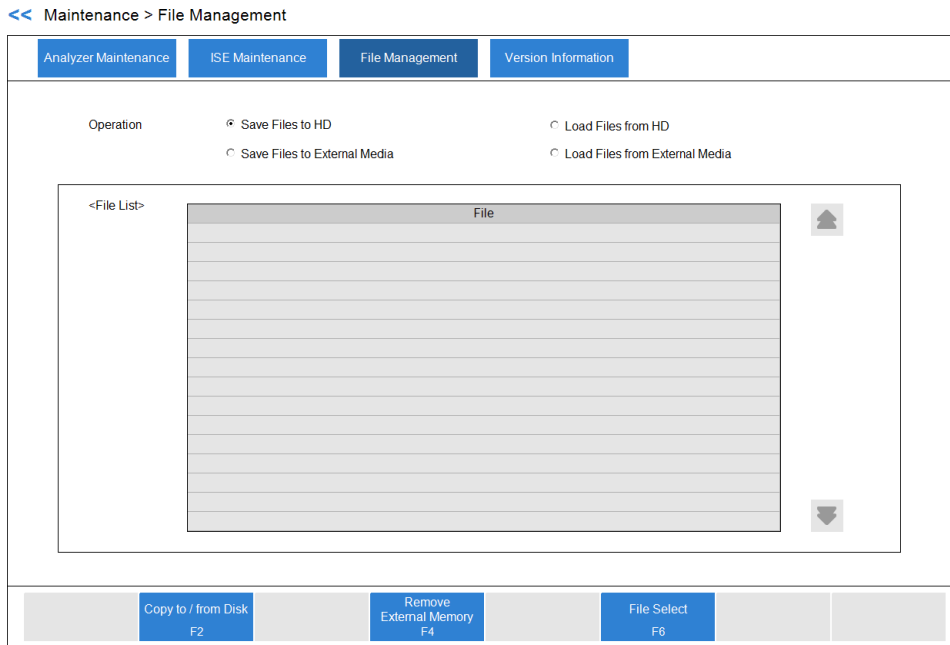

2 In **Operation**, select **Save Files to HD, Load Files from HD, Save Files to External Media, or Load Files from External Media.**

When you save files to HD, you save them to a backup folder on the hard drive.

3 Select **File Select [F6]**.
The system displays the File Select dialog.

Figure 4.51 File Select Dialog

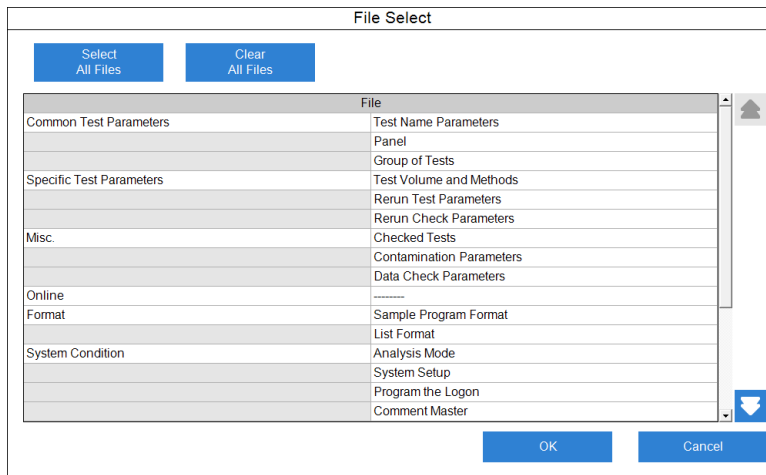

4 Select the files to save or load. Select a menu in the left column to include all the submenus, or select individual submenus in the right column.

5 Select **Select All Files** to select all files. Select **Clear All Files** to clear the selection of all files.

6 Select **OK**.

The system displays the selected files.

Figure 4.52 File Management Screen

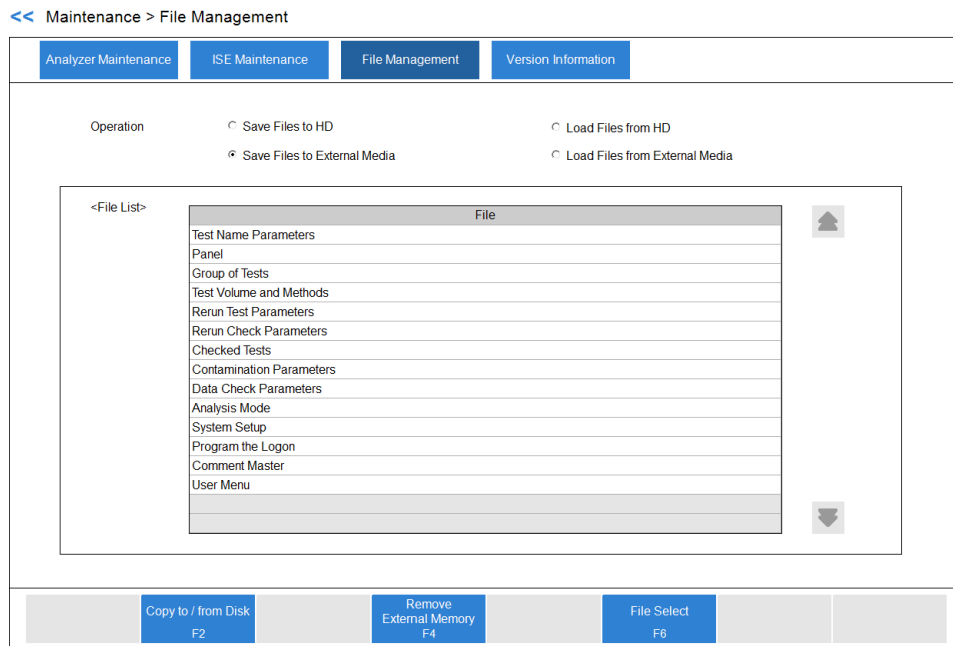

7 Select **Copy to/from Disk** [F2].

a. If saving or loading using external media, select **CD-R** or **External Memory Device**, and then select **OK**.

Figure 4.53 Copy to/from Disk Dialog

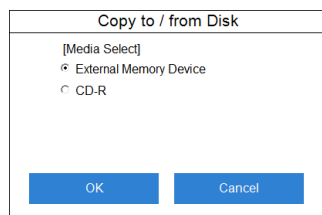

b. If saving or loading using HD, select **OK**.

Figure 4.54 Copy to/from Disk Dialog

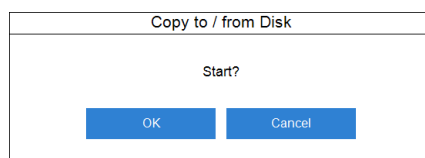

System Monitoring and Results

Save or Load Parameters



Caution

If you save parameters to a hard drive or external memory device, the system overwrites the existing parameters without warning.

The Copy to Disk dialog or Copy to/from Disk dialog displays when the operation completes.

Figure 4.55 Copy to Disk Dialog

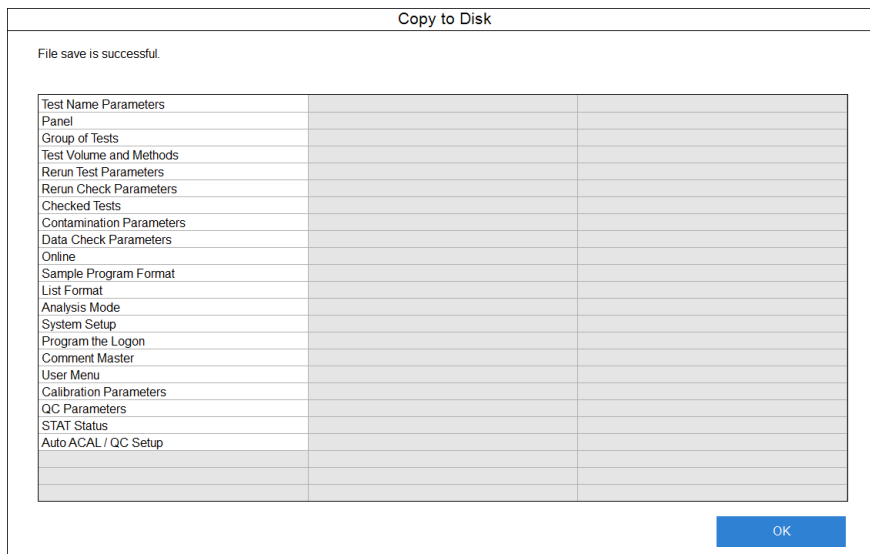
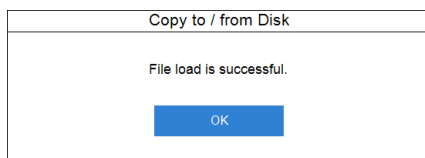

Figure 4.56 Copy to/from Disk Dialog



-
- 8 Select **OK**.
You can remove the external media.
-

Sample Bar Code Label Specifications

Use a bar code label for the sample ID for analysis. The following sections define the bar code label specifications used for identifying samples on the DxC 700 AU.

Bar Code Types

Sample bar codes include the following types:

- NW-7
- CODE 39
- CODE 128, ISBT-CODE 128
- INT (Interleaved 2 of 5)
- Standard 2 of 5

The system can read multiple bar code types when using a mixture of NW-7, CODE 39, CODE 128, INT (interleaved 2 of 5), or Standard 2 of 5. The specifications of individual bar codes comply with the following standards.

Table A.1 Compatible Standard

Bar Code	Compatible Standard
NW-7	JIS-X-0506, USS-NW7
CODE 39	JIS-X-0503, USS-CODE 39
CODE 128	JIS-X-0504, USS-CODE 128
ISBT-CODE 128	ISBT 128
INT (Interleaved 2 of 5)	JIS-X-0502, USS-I2/5

Table A.2 Character Font

Bar Code	Character Font
NW-7	0 to 9
CODE 39	Alphanumerics, special characters
CODE 128	Alphanumerics, special characters
ISBT-CODE 128	Alphanumerics, special characters
INT (Interleaved 2 of 5)	0 to 9
Standard 2 of 5	0 to 9

Bar Code Digit Numbers

Bar codes can contain a maximum of 26 digits.

Specifications

Sample Bar Code Label Specifications



Note

Refer to the Laboratory Automation System manual for bar code types available when the DxC 700 AU is connected to a Laboratory Automation System.

The bar code digit specification is 0 to 17 digits when the DxC 700 AU is connected to a Laboratory Automation System.

Bar Code Label Size

The size of sample bar code labels must follow the following specifications. (The units are in millimeters.)

- Label length (A) < Sample tube length - 12
- Label width (B) = a minimum of $D+10$, and not so wide that the label interferes with the bar code area.

In other words, B is equal to or less than the tube circumference. If the label is wider than the tube circumference, it wraps around the tube and might overlap the bar code.

- Bar code height (D) ≥ 10
- Top and bottom margin (M)
 - CODE 128: 10 times X or 2.54, whichever is larger
 - (X: minimum width of a module)
 - Other than CODE 128: 3 or more
- Bar code area (C) = $A - 2 \times M$

Figure A.1 Sample Bar Code Label Specifications

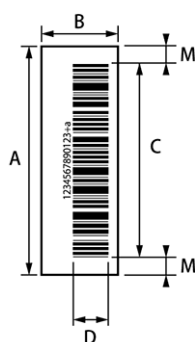

- A: Label length
- B: Label width
- C: Bar code area
- D: Bar code height
- M: Top and bottom margin (quiet zone)

Bar and Space Widths

Bars and spaces must have the following widths:

Table A.3 Bar and Space Widths

	NB (narrow bar)	NS (narrow space)	WB (wide bar)	WS (wide space)	G (gap)	X¹
Minimum	0.165 to 0.2 mm	NB to 1.25 NB	2.2 NB to 3.0 NB	2.2 NB to 3.0 NB	NB to 3.0 NB	0.191 or more
Maximum	0.2 to 0.5 mm		2.0 NB to 3.0 NB	2.0 NB to 3.0 NB	NB to 3.0 NB	

1. Minimum width of a module for CODE 128

Bar Code Check Methods

To configure the mode for bar code checking, select the mode in **Check Mode** in the Analysis Mode screen (**CONFIG. > Analysis Mode**). Refer to [Analysis Mode Screen](#).

Available bar code check methods:

1. **Yes:** Reads the bar code with a check character, and performs the check with a method listed in [Table A.4 Check Method](#).

The system does not output the check character.

2. **No (With Chk. Chr.):** Reads the bar code with a check character, but does not perform the check.

The system does not output the check character.

3. **No (No Chk. Chr.):** Reads the bar code without a check character, and does not perform the check.

CODE 128 and ISBT-CODE 128 require a check character. You cannot select these codes with the above methods 2 and 3.

Table A.4 Check Method

Bar Code	Check Character Position and Method
NW-7	Least significant digit, MODULUS-16
CODE 39	Least significant digit, MODULUS-43
CODE 128, ISBT-CODE 128	Least significant digit, MODULUS-103
INT (Interleaved 2 of 5) and Standard 2 of 5	Least significant digit, MODULUS-10

The check method is fixed for each bar code type. You cannot select the check method.

Requirements for Printing Bar Code Labels

To maintain readout accuracy, print bar code labels according to the following requirements.

- PCS value

Specifications

Sample Bar Code Label Specifications

If the NB (narrow bar) width is between 0.165 and 0.50 mm the PCS value must be 0.60 or more.

If the NB (narrow bar) width is between 0.130 and 0.156 mm the PCS value must be 0.85 or more.

Figure A.2

$$\text{PCS Value} = \frac{R_L - R_D}{R_L} \quad \begin{array}{l} R_L : \text{white bar and margin reflection rate} \\ R_D : \text{black bar reflection rate} \end{array}$$

- CODE 128: The MRD must be 37.5% or more.
- A void on a white bar (damage or print loss on a bar), ink spot (ink stain), or thin spot must satisfy the following restrictions:
 - The spot diameter is 0.05 mm or less.
 - The void is 25% or less in a circular area with a diameter of 0.1 mm.
 - No marked blurring.

Additional Software Screens

Sample Status Screen

Figure B.1 Test Results: Sample Status Screen

<< Results > Sample Status

Sample Status		Detail		Realtime Display		Sample Manager		ISE Calibration		
							View mode		Realtime	
Sample No.	Cup Position	Sample ID	Order	Status	Results	Last Name				
0018	0073-09	105287	07:32	Done		TUCKER				
0019	0073-10	101596	07:33	Done		SANCHEZ				
0020	0037-01	208372	07:33	Done		KENNEDY				
0021	0037-03	101835	07:33	Done		KENT				
0022	0037-05	101638	07:33	Done		CLEAVER				
0023	0037-06	101437	07:34	Done		BEMIS				
0024	0037-07	101526	07:34	Done		JETSON				
0025	0029-03	101729	07:35	Done		STEVENS				
0026	0029-06	105733	07:35	Done		MORALES				
U0027	0058-01	313395	07:48	In Process	07:58	DUNCAN				
0028	0058-02	416242	07:48	In Process	07:59	ARMSTRONG				
0029	0058-04	105837	07:48	In Process	07:59	JOHNSON				
U0030	0058-07	313371	07:48	In Process	07:59	FISHER				

Find F2 Rerun F3 Switch to Static View F4 Reaction Monitor F6

Additional Software Screens

Detail Screen

Detail Screen

Figure B.2 Test Results: Detail Screen

<< Results > Detail

Sample Status
Detail
Realtime Display
Sample Manager
ISE Calibration

Sample No. Type Cup Position -

Results Sample ID Sample Dilution Rate Status

Last Name

Test Name	Result	Flags	Test Name	Result	Flags	Normal	Diluted	Concentrated	Flags
Na	133		K	4.78		CI	100		
CO22U	07:58		Lipemia	07:58		Icterus	07:58		
Hemolysis	07:58								

< Contents of Error >

Rerun
F3

Realtime Display Screen

Figure B.3 Realtime Display: All Tab

<< Results > Realtime Display

Sample Status
Detail
Realtime Display
Sample Manager
ISE Calibration

All
Quick
ISE

View mode
Static

Sample No.0009	Serum	Sample ID 208931	4.50	CI	Last Name	DAVIS
Na	127 L	K	35 H	CRE1U	98	14 L
GLU1U	189 H	BUN1U			3.42 H	CO22U
Sample No.0010	Serum	Sample ID 101567			Last Name	PARKER
Na	134	K	4.71	CI	98	AST1U
LDH1U	182 n					79 n
Sample No.0011	Serum	Sample ID 416957			Last Name	NGUYEN
Na	131	K	4.58	CI	99	CO22U
GLU1U	190 H	BUN1U	36 H	CRE1U	3.50 H	13 L
Sample No.0012	Serum	Sample ID 208137			Last Name	SMITH
Na	133	K	4.70	CI	99	CO22U
GLU1U	200 H	BUN1U	38 H	CRE1U	3.60 H	14 L
Sample No.0013	Serum	Sample ID 101375			Last Name	WEST
Na	134	K	4.82	CI	100	AST1U
LDH1U	185 n					111 n H
Sample No.X0014	CSF	Sample ID 105461			Last Name	JENKINS
GLU1U	111 H					
Sample No.0015	Serum	Sample ID 101264			Last Name	EDWARDS
Na	135	K	4.77	CI	99	AST1U
LDH1U	180 n					75 n
Sample No.X0016	CSF	Sample ID 105396			Last Name	KELLY
GLU1U	152 H					
Sample No.0017	Serum	Sample ID 105942			Last Name	HILL
Na	133	K	4.78	CI	100	AST1U
LDH1U	183 n					106 n H
Sample No.0018	Serum	Sample ID 105287			Last Name	TUCKER
Na	133	K	4.73	CI	97	AST1U
LDH1U	182 n					81 n H
Sample No.0019	Serum	Sample ID 101596			Last Name	SANCHEZ
Na	134	K	4.73	CI	98	AST1U
						91 n H

Find
F2

Switch to Realtime View
F4

Reaction Monitor
F6

Sample Manager Screen

Figure B.4 Sample Manager: Main Tab

<< Results > Sample Manager

Sample Manager
Reaction Monitor
Data Statistics
Correlation Chart

Main
By Patient Sample
By Patient Test

Index
2.12/08/2017 08:04
-
2.12/08/2017 08:04

Select All Samples
Clear All Samples
 Abnormal
 Rerun Data

No. [1]	Sample No.	Cup Position	Sample ID	Run Date/Time	Status	Last Name
9	Q001	0009-01	QC1	12/08/2017 08:58:03	Done	General QC Level 1
10	Q001	0009-02	QC3	12/08/2017 08:59:15	Error	General QC Level 3
11	Q001	0009-05	U1	12/08/2017 08:59:34	Error	Urine QC L1
12	Q001	0009-06	U2	12/08/2017 08:59:38	Error	Urine QC L3
13	Q001	0009-07	C1	12/08/2017 08:59:52	Done	CSF Level 1
14	Q001	0009-08	C2	12/08/2017 08:59:56	Done	CSF Level 2
15	P001	STAT-05	93077	12/08/2017 09:00:23	Done	Reynolds
16	0001	0073-01	105837	12/08/2017 09:00:41	Done	JOHNSON
17	0002	0073-02	416242	12/08/2017 09:00:50	Done	ARMSTRONG
18	U0003	0073-03	313360	12/08/2017 09:01:00	Done	FOX
19	0004	0073-04	313591	12/08/2017 09:01:09	Done	IRWIN
20	0005	0073-05	313509	12/08/2017 09:01:49	Done	GRANT
21	P002	STAT-14	313328	12/08/2017 09:02:12	Done	ODONNELL
22	U0006	0073-06	313371	12/08/2017 09:02:16	Done	FISHER
23	U0007	0073-07	313395	12/08/2017 09:02:21	Done	DUNCAN
24	Q002	0009-05	U1	12/08/2017 09:21:08	Error	Urine QC L1
25	Q002	0009-06	U2	12/08/2017 09:21:12	Error	Urine QC L3

Copy to Disk
F2
Find
F3
Remove External Memory
F4
Recalculate Data
F5
Data Correction
F6
Send to LIS
F7
Print
F8

Rack (Patient) Screen

Figure B.5 Rack (Patient): Test Order Tab

<< Sample Program > Rack (Patient)

Rack (Patient)
Rack (Calibration)
Rack (QC)

Test Order
Demographics

Sample Kind Routine
Switch
Sample No. 0004
Type Serum

Sample ID
Samples Remaining 9996
Sample Dilution Rate 1

Panel
 Change Group Display
Group of Tests 1:Analysis Test

*: Analyzed Test					Normal	Diluted	Concentrated
ALT	CHOL	GGT19	LDH	GLUC	CRP	ALB	AMY
Cl	K	Na					

Search by Sample ID
Test Total
Select Auto Rerun Orders
Perform Replicates
Selected Tests 0

Sample Volume(uL) 0
(not include dead volume)

Rerun
F3
Pending List
F4
Batch Entry
F5
Delete Test Order
F6
Batch Order from LIS
F7
Print
F8

STAT Status Screen

Figure B.8 STAT Status Screen

<< STAT > STAT Status

STAT Status		STAT (Patient)		STAT (Calibration)		STAT (QC)		Auto ACAL / QC Setup	
Pos	Kind	Cup	Status	Sample No.	Type	Cup Information		ID	Comment
1	Patient	None							
2	Free	None							
3	Free	None							
4	Free	None							
5	Free	None							
6	Free	None							
7	Patient	None							
8	Patient	None							
9	Patient	None							
10	Patient	None							
11	Patient	None							
12	Patient	None							
13	Patient	None							
14	Patient	None							
15	Patient	None							
16	Patient	None							
17	Patient	None							
18	Patient	None							
19	Patient	None							
20	Patient	None							
21	Patient	None							
22	Patient	None							

Pos	Cup	Status	Cup Information	Comment
RB1	None		DI Water	
RB2	None			

STAT Pause F2	STAT Check F3	Display Sample Assignment F4	CAU/QC Position F5	STAT Table Setting F6	Previous Cup Set F7	Sample ID Edit F8
------------------	------------------	---------------------------------	-----------------------	--------------------------	------------------------	----------------------

STAT (Patient) Screen

Figure B.9 STAT (Patient): Test Order Tab

<< STAT > STAT (Patient)

STAT Status		STAT (Patient)		STAT (Calibration)		STAT (QC)		Auto ACAL / QC Setup	
-------------	--	----------------	--	--------------------	--	-----------	--	----------------------	--

Test Order | Demographics

Cup Pos: [] Sample Kind: STAT Sample No.: 001 Type: Serum

Sample ID: [] Samples Remaining: 9996 Sample Dilution Rate: 1

Panel [] Change Group Display Group of Tests: 1 Analysis Test

* : Analyzed Test

ALT	CHOL	GGT19	LDH	GLUC	CRP	ALB	AMY
Cl	K	Na					

Selected Tests: 0
 Sample Volume(uL): 0 (not include dead volume)

Search by Sample ID	Test Total	Select Auto Rerun Orders	Perform Replicates	Rerun F3	Pending List F4	Batch Entry F5	Delete Test Order F6	Batch Order from LIS F7	Print F8
---------------------	------------	--------------------------	--------------------	-------------	--------------------	-------------------	-------------------------	----------------------------	-------------

Additional Software Screens

STAT (Calibration) Screen

STAT (Calibration) Screen

Figure B.10 STAT (Calibration) Screen

<< STAT > STAT (Calibration)

STAT Status
STAT (Patient)
STAT (Calibration)
STAT (QC)
Auto ACAL / QC Setup

Type Serum

Panel One Point

Test Name	RB	Cal.	Test Name	RB	Cal.	Test Name	RB	Cal.
Na			K			Cl		
CO22U			GLU1U			CRE1U		
BUN1U			CAZ1U			ALB1U		
TP-1U			PHO1U			LIH		
MG-1U			TBC1U			AST1U		
LDH1U								

Selected Tests RB Cal.

Individual Order
F3
Auto CAL/QC Order
F4
QC Same Order
F5
CAL/QC Position
F6

STAT (QC) Screen

Figure B.11 STAT (QC) Screen

<< STAT > STAT (QC)

STAT Status
STAT (Patient)
STAT (Calibration)
STAT (QC)
Auto ACAL / QC Setup

Type Serum

Panel

ALT	CHOL	GGT19	LDH	GLUC	CRP	ALB	AMY
Cl	K	Na					

Selected Tests

QC Program by Panel

First Bottle Only Multiple Bottles

Individual Order
F3
Select All Tests
F5
Clear All Tests
F6
CAL/QC Position
F7

AUTO ACAL/QC Setup Screen

Figure B.12 AUTO ACAL/QC Setup Screen

Test Name	Available/Unavailable	Auto ACAL/RB	RB Execution Type	ACAL Execution Type
11.TP	Available	No	Change Lot No.	None
97.Na	Unavailable	No	Change Lot No.	None
98.K	Unavailable	No	Change Lot No.	None
99.Cl	Unavailable	No	Change Lot No.	None
18.CO2	Available	No	Change Lot No.	None
15.AST	Available	No	Change Lot No.	None
8.BUN	Available	No	Change Lot No.	None
9.GGT	Available	No	Change Lot No.	None
10.LDH	Available	No	Change Lot No.	None
12.ALP	Available	No	Change Lot No.	None
14.ALT	Available	No	Change Lot No.	None
20.GLU	Available	No	Change Lot No.	None
21.ALB	Available	No	Change Lot No.	None
22.CA	Available	No	Change Lot No.	None
27.CHOL	Available	No	Change Lot No.	None
28.TRIG	Available	No	Change Lot No.	None
25.TBILB	Available	No	Change Lot No.	None
17.CREA	Available	No	Change Lot No.	None

Analyzer Maintenance Screen

Figure B.13 Analyzer Maintenance Operation Buttons

No. [n]	Maintenance	Help	Next Due (Cycle Count)	Performed	Frequency
1	Clean the Sample Probe (1)	?	01/01/2018 08:44	12/25/2017 08:44	Weekly
2	Clean the Mix Bars (0)	?	01/01/2018 08:44	12/25/2017 08:44	Weekly
3	Perform a W2 (0)	?	01/01/2018 07:44	12/25/2017 07:44	Weekly
4	Perform a Photocal (1)	?	01/01/2018 07:44	12/25/2017 07:44	Weekly
5	Clean the Pre-dilution Bottle (0)	?	01/01/2018 08:44	12/25/2017 08:44	Weekly
6	Clean the Sample Probe Wash Well (0)	?	01/25/2018 08:48	12/25/2017 08:48	Monthly
7	Clean the Reagent Probe Wash Wells (0)	?	01/25/2018 08:48	12/25/2017 08:48	Monthly
8	Clean the HbA1c Wash Well (0)	?	01/25/2018 08:46	12/25/2017 08:46	Monthly
9	Clean the Mix Bar Wash Wells (0)	?	01/25/2018 08:48	12/25/2017 08:48	Monthly
10	Clean the Wash Nozzle and Inspect the Tube Mounting Joints (0)	?	01/25/2018 08:48	12/25/2017 08:48	Monthly

1. Analyzer Maintenance box

2. Maintenance operation buttons

ISE Maintenance Screen

Figure B.14 ISE Maintenance Operation Buttons

<< Maintenance > ISE Maintenance

Analyzer Maintenance
ISE Maintenance
File Management
Version Information

Maintenance
Calibration
Selectivity Check
Measurement

Display Pending Procedures Only
 Procedures Due Soon

No. [?]	Maintenance	Help	Next Due (Cycle Count)	Performed	Frequency	Update	Update Approval Date
1	Clean the ISE (2)	[?]	12/26/2017 09:24	12/25/2017 09:24	Daily	<input checked="" type="checkbox"/> ISE Maintenance Total Prime Prime Bypass Buffer Prime MID/REF Prime Drain Flow Cell Drain Bypass	
2	Serum Calibration (1)	[?]	12/26/2017 09:24	12/25/2017 09:24	Daily		
3	Urine Calibration (1)	[?]	12/26/2017 09:24	12/25/2017 09:24	Daily		
4	Selectivity Check for the Na/K Electrodes (1)	[?]	01/01/2018 09:24	12/25/2017 09:24	Weekly		
5	Enhanced Cleaning of Electrode Line (2)	[?]	01/01/2018 09:24	12/25/2017 09:24	Weekly		
6	Manually Clean the ISE Sample Pot (2)	[?]	01/08/2018 09:16	12/25/2017 09:16	2Weeks		
7	Manually Clean the ISE Mix Bar and Liquid Level Sensors (2)	[?]	01/08/2018 09:16	12/25/2017 09:16	2Weeks		
8	Replace ISE Tubing (2)	[?]	01/06/2018 13:52	12/06/2017 13:52	Monthly		
9	Inspect and Add ISE Internal Reference Solution (2)	[?]	02/06/2018 13:52	12/06/2017 13:52	2Months		
10	Manually Clean the Drain Well (0)	[?]	03/06/2018 13:52	12/06/2017 13:52	3Months		

(0) No Action
(1) Perform QC
(2) Perform Calibration and QC

Edit Maintenance
Maintenance History
Maintenance Schedule
Print

1. ISE Maintenance box
2. Maintenance operation buttons

Version Information Screen

Figure B.15 Version Information Screen

<< Maintenance > Version Information

Analyzer Maintenance
ISE Maintenance
File Management
Version Information

System / Console

Program	Ver.	Rev.
System	1	04
Console	1	25
Help	1	00
-----	--	--

Analyzer

Program	Ver.	Rev.	Station	Program	Ver.	Rev.	Station
Analyzer IPL ROM			---	Rack Back, Transfer Controller(CF,CG)	3	2	31
Analyzer Control Program			---	Temperature Controller (Incubation,Fan)	3	1	28
Primary Station Firmware	3	4	0	Temperature Controller (Wash and DI Water)	3	1	27
Reagent Refrigerator Controller(DA01)	3	2	2	Dilution Pump Controller	3	2	9
Reagent Refrigerator Controller(DA11)	3	2	3	ISE Data Controller	3	5	13
STAT Table Controller(DC)	3	2	8	ISE Mixer Controller	3	2	15
Sample Probe Controller(FA)	3	2	7	ISE Pump Controller	3	2	14
Cuvette Washer Controller(FB)	3	2	29	-----	--	--	---
Mixer Controller(FC01)	3	2	26	-----	--	--	---
Mixer Controller(FC11)	3	2	6	-----	--	--	---
R1 Probe Controller(FD01)	3	2	5	-----	--	--	---
R2 Probe Controller(FD11)	3	2	4	-----	--	--	---
Photometry Controller(GA)	2	1	200	-----	--	--	---
Sample Dispenser Controller(SA)	3	2	10	-----	--	--	---
R1 Dispenser Controller(SA)	3	2	11	-----	--	--	---
R2 Dispenser Controller(SA)	3	2	12	-----	--	--	---
Rack Transfer Controller(CB,CJ)	3	2	32	-----	--	--	---
Rack Extrusive Controller(CC)	3	2	33	-----	--	--	---
Normal Lane Controller(CD)	3	2	34	-----	--	--	---
Buffer,Repeat Controller(CE,CH)	3	2	30	-----	--	--	---

Print F8

Calibrate the ISE Screen

Figure B.16 ISE Maintenance: Calibration Tab

<< Maintenance > ISE Maintenance

Analyzer Maintenance
ISE Maintenance
File Management
Version Information

Maintenance
Calibration
Selectivity Check
Measurement

ISE Status: READY
Electrode Status: Na K Cl
Reagent Status: REF MID Buffer

< Result >

Date/Time	Serum						Urine					
	Na	Slope		MID Solution Factor			Na	Slope		MID Solution Factor		
Last Result	54.6	54.9	-54.2	1.000	1.000	0.900	54.5	55.0	-55.5	1.100	1.000	1.100
12/18/2015 11:11	54.6	54.9	-54.2	1.000	1.000	0.900	54.5	55.0	-55.5	1.100	1.000	1.100
12/18/2015 11:09							54.0	54.2	-55.5	1.200	1.100	1.100
12/18/2015 11:07	53.0	55.0	-54.0	1.100	1.000	1.100						
12/18/2015 10:46	55.0	55.0	-55.0	1.100	0.900	1.200	54.0	54.0	-56.0	1.200	1.200	1.100

< Acceptable Calibration Range >

	High	Low	High	Low	High	Low	High	Low	High	Low	High	Low
	68.0	38.0	68.0	-38.0	1.200	0.800	1.200	0.800	68.0	38.0	68.0	-38.0
	38.0	38.0	-68.0	-68.0	0.800	0.800	0.800	0.800	38.0	38.0	-68.0	-68.0

Serum Start
Urine Start
Serum/Urine Start

ISE Stop
F4
Graph Display
F5
Detail
F6
Print
F8

User Menu Screen

Figure B.17 User Menu Screen

<< Configuration Parameters > System Condition > User Menu

Analysis Mode
System Setup
Program the Logon
Comment Master
User Menu

Inspect Analyzer Status

Analyzer Daily Maintenance
Perform Routine Inspections

Monitor Reagent Status
Perform Reagent Volume Check

Inspect ISE Reagents
Review Number of Tests and Stability

ISE Daily Maintenance
Clean and Calibrate the ISE

Order and Perform Calibration from Racks

Review Calibration Data
Recent and History

Order and Perform QC from Racks

Review QC Data
Charts

Monitor Results
Status, Time to Completion, Flags

Edit
F1

Additional Software Screens

User Menu Screen

End-User License Agreement and Open Source Software Notice

End-user License Agreement

 Important

READ THIS END-USER LICENSE AGREEMENT:

THIS END-USER LICENSE AGREEMENT ("**Agreement**") GOVERNS THE USE OF CERTAIN COMPUTER PROGRAMS CONTAINED IN THE BECKMAN COULTER, INC. ("**BCI**") PRODUCT PROVIDED BY BCI OR ON BEHALF OF BCI ("**BCI Product**"). ACCEPTANCE OF THE PRICE QUOTE (BY SUBMISSION OF A PURCHASE ORDER OR OTHERWISE) FOR OR USE OF THE BCI PRODUCT CONSTITUTES ASSENT AND ACCEPTANCE OF THIS AGREEMENT BY YOU AND THE BUSINESS ENTITY ON WHOSE BEHALF THE BCI PRODUCT IS PROVIDED (collectively "**You**" or "**Your**") AND SIGNIFIES YOUR AGREEMENT TO BE BOUND BY THE TERMS AND CONDITIONS OF THIS AGREEMENT. BCI'S ACCEPTANCE OF AN ORDER FOR THE BCI PRODUCT IS CONDITIONAL UPON YOUR ASSENT TO THE TERMS OF THIS AGREEMENT TO THE EXCLUSION OF ALL OTHER TERMS. IF YOU DO NOT AGREE WITH ALL OF THE TERMS AND CONDITIONS OF THIS AGREEMENT, YOU DO NOT HAVE THE RIGHT TO AND MAY NOT USE THE BCI PRODUCT OR THE COMPUTER PROGRAMS CONTAINED IN THE BCI PRODUCT.

1. **GRANT OF LICENSE.** Subject to all of the terms and conditions of this Agreement, BCI grants to You a non-exclusive, non-sublicensable and non-transferable license ("**License**") to use the computer programs, including any updates or upgrades (in object code form only) contained in the BCI Product ("**Programs**") and the associated user documentation ("**Documentation**") (together with the Programs referred to herein, collectively, as the ("**Software**")) only as incorporated within the BCI Product and only in accordance with the Documentation. You have no right to receive, use or examine any source code or design documentation relating to the Programs. The Software is licensed and not sold. As between the parties, BCI and its licensors retains all right, title and interest in and to the Software and any and all derivative works, except as expressly and unambiguously licensed herein, and BCI reserves all rights in the Software not granted to You. In order to use the Software, You may be required to input a registration number or product authorization key and register Your copy of the Software with BCI to obtain the necessary license key or license file. Except as otherwise expressly provided under the Agreement, You shall only use the Software in connection with the use of BCI Product provided to You from BCI or a third party on BCI's behalf and only for Your internal business purposes.
2. **RESTRICTIONS.** Other than as expressly permitted under applicable law, You shall not (and shall not allow others to): (i) copy the Software, except as reasonably required to use the Programs strictly in accordance with this Agreement, (ii) alter, adapt, translate or create derivative works based upon the Software, or include the Programs in any other products or software, (iii) decompile, disassemble, reverse engineer or otherwise attempt to discover or reconstruct the source code (or underlying ideas, sequence, structure organization or algorithms) of any of the Programs, or attempt to do so, except to the limited extent the foregoing is expressly permitted by applicable law, in

End-User License Agreement and Open Source Software Notice

End-user License Agreement

which case You must first notify BCI in writing and request interoperability information regarding the Programs, (iv) provide, rent, loan or lease the Software to any other party or provide any information services to any other party through the use of the Software, whether in the form of a timesharing service, service bureau or other information processing service, (v) remove, modify or obscure any product identification, copyright notice, trademark, and/or any other proprietary legend contained in the Software, (vi) disseminate performance information or analysis relating to the Programs (vii) use the Programs in hazardous environments requiring fail-safe performance in which the failure of the Programs could lead to death, personal injury or environmental damage, or (viii) tamper with, bypass, circumvent, or alter the security features of the Program. You hereby acknowledge and agree that the Program may stop working and become unusable for tampering of the security management technology.

3. **TERMINATION.** The License is effective until terminated. You may terminate the Agreement and the License at any time by destroying all copies of the Program. Your rights under this License will terminate automatically without notice if You fail to comply with any provision of this Agreement. Within fourteen (14) days following termination, You shall cease all use of, and destroy, all copies of the Software in Your possession or control and so certify to BCI in writing. Except for the License, the terms of this Agreement shall survive termination. Termination is not an exclusive remedy and all other remedies will be available to BCI whether or not the License is terminated.
4. **PRODUCT SUPPORT.** Please refer to the BCI support number provided in the Documentation for the BCI Product for information regarding support of the BCI Product.
5. **DISCLAIMER OF WARRANTY.** TO THE MAXIMUM EXTENT PERMITTED BY LAW, THE SOFTWARE IS PROVIDED "AS IS" WITHOUT WARRANTY OF ANY KIND, AND BCI DISCLAIMS ALL WARRANTIES, EITHER EXPRESS OR IMPLIED, INCLUDING, BUT NOT LIMITED TO, IMPLIED WARRANTIES AND CONDITIONS OF TITLE, MERCHANTABILITY, SATISFACTORY QUALITY, FITNESS FOR A PARTICULAR PURPOSE AND NON INFRINGEMENT. BCI DOES NOT WARRANT THAT THE SOFTWARE WILL BE ERROR-FREE, THAT USE OF THE PROGRAMS WILL BE FREE FROM INTERRUPTION OR OTHER FAILURES, THAT ANY ERRORS OR DEFECTS IN THE SOFTWARE WILL BE CORRECTED OR THAT THE SOFTWARE WILL SATISFY YOUR SPECIFIC REQUIREMENTS. YOU ACKNOWLEDGE AND AGREE THAT BCI DOES NOT WARRANT, GUARANTEE, OR MAKE ANY REPRESENTATIONS REGARDING THE PERFORMANCE, USE OR RESULTS OF THE USE OF THE SOFTWARE (INCLUDING IDENTIFIED COMPONENTS) OR ITS CORRECTNESS, ACCURACY, RELIABILITY, CURRENTNESS, OR OTHERWISE. YOU ASSUME THE ENTIRE RISK ASSOCIATED WITH YOUR USE OF THE SOFTWARE. THIS DISCLAIMER OF WARRANTY IS AN ESSENTIAL PART OF THIS AGREEMENT. SOME JURISDICTIONS DO NOT ALLOW THE EXCLUSION OF IMPLIED WARRANTIES OR CONDITIONS, SO THE FOREGOING DISCLAIMER MAY NOT APPLY TO YOU. IN THE EVENT THE DISCLAIMER OF IMPLIED WARRANTIES IS NOT ENFORCEABLE UNDER APPLICABLE LAW, ANY IMPLIED WARRANTIES SHALL BE LIMITED TO NINETY (90) DAYS FOLLOWING DELIVERY OF THE BCI PRODUCT.
6. **LIMITATION OF LIABILITY.** NOTWITHSTANDING ANYTHING ELSE IN THIS AGREEMENT, TO THE MAXIMUM EXTENT PERMITTED BY LAW, NEITHER BCI OR ITS LICENSORS SHALL BE LIABLE WITH RESPECT TO ANY SUBJECT MATTER OF THIS AGREEMENT UNDER ANY CONTRACT, NEGLIGENCE, STRICT LIABILITY OR OTHER LEGAL OR EQUITABLE THEORY FOR LOSS OF OR INTERRUPTION TO BUSINESS; LOSS OF PROFITS OR GOOD WILL; LOSS OF USE; LOSS OR DAMAGE TO OR CORRUPTION OF DATA; DAMAGE TO ANY OTHER SOFTWARE, HARDWARE OR OTHER EQUIPMENT;

UNAUTHORIZED ACCESS TO OR ALTERATIONS OF DATA; UNAUTHORIZED DISCLOSURE OF SENSITIVE, CONFIDENTIAL OR PROPRIETARY INFORMATION; ANY COSTS OF PROCURING SUBSTITUTE GOODS, SERVICES, TECHNOLOGY OR RIGHTS; ANY INDIRECT, SPECIAL, CONSEQUENTIAL, EXEMPLARY OR INCIDENTAL DAMAGES; OR ANY AMOUNT IN EXCESS OF TWO HUNDRED FIFTY DOLLARS (US\$250.00). THE LIMITATIONS IN THIS SECTION 6 SHALL NOT LIMIT BCI'S LIABILITY FOR DEATH OR BODILY INJURY SOLELY RESULTING FROM BCI'S NEGLIGENCE, WILLFUL MISCONDUCT OR FRAUDULENT MISREPRESENTATION.

7. **U.S. GOVERNMENT USERS.** The Software is a "commercial item" consisting of "commercial computer software" and/or "commercial computer software documentation" as such terms are defined in the Federal Acquisition Regulations ("FAR") section 2.101, and the Defense Federal Acquisition Regulations ("DFAR") section 252.227-7014(a)(I) and DFAR section 252.227-7014(a)(5). Consistent with FAR section 12.212 and DFAR section 227.7202-1 through 227.7202-4, any use of the Software by or on behalf of an agency or other instrumentality of the U.S. Government shall be governed solely by the terms of this Agreement and shall be prohibited except to the extent expressly permitted by the terms of this Agreement. You will ensure that each copy of the Software used by or for the U.S. Government is labeled to reflect the foregoing.
8. **EXPORT.** Software, including technical data, is subject to U.S. export control laws, including the U.S. Export Administration Act and its associated regulations, and may be subject to export or import regulations in other countries. You agree to comply strictly with all such regulations and acknowledge that you have the responsibility to obtain licenses to export, re-export, or import Software.
9. **THIRD PARTY COMPONENTS; ADDITIONAL TERMS.** The Software may contain or be delivered with one or more components, which may include third-party components, identified by BCI in the Documentation, readme.txt file, third-party click-accept or on www.beckman.com/thirdpartysoftware (the "Identified Component(s)") as being subject to different license agreement terms, disclaimers of warranties, limited warranties or other terms and conditions (collectively, "Additional Terms") than those set forth herein. You agree to the applicable Additional Terms for any such Identified Component(s). Such Identified Components are the sole responsibility of the licensor of that Identified Component. BCI is not responsible for any Identified Component, whether or not BCI reviewed or modified such component.
10. **CONFIDENTIALITY.** The Software embodies logic, design, architecture, algorithms and coding methodology which constitute valuable confidential information that is proprietary to BCI and its licensors. You agree to safeguard the right to access the Software using the same standard of care which You use for Your similar confidential materials, but in no event less than reasonable care. You agree not to provide or to otherwise make available in any form the Software, or any portion thereof, to any person other than to Your employees or contractors with a need to know, without the prior written consent of BCI.
11. **MISCELLANEOUS.** You may not assign this Agreement or any of Your rights hereunder without BCI's prior written consent and any attempt to do so without such consent shall be null and void. No failure to exercise any right hereunder will operate as a waiver thereof. If any provision of this Agreement shall be adjudged by any court of competent jurisdiction to be unenforceable or invalid, that provision shall be limited or eliminated to the minimum extent necessary so that this Agreement shall otherwise remain in full force and effect and enforceable. This Agreement shall be construed in

End-User License Agreement and Open Source Software Notice

Open Source Software Notice

accordance with the laws of the State of California and the United States without regard to conflicts of laws provisions thereof and without regard to the United Nations Convention on Contracts for the International Sale of Goods. The sole and exclusive jurisdiction and venue for any actions related to the subject matter hereof shall be the state and U.S. federal courts located in the County of Orange, California. You irrevocably submit to the jurisdiction of such courts and consent to venue in such forum with respect to any action or proceeding that relates to this Agreement. The prevailing party in any action to enforce this Agreement shall be entitled to recover its reasonable costs and expenses including reasonable attorneys' fees. No amendment to or modification of this Agreement will be binding unless in writing and signed by a duly authorized officer of BCI. This Agreement is in the English language only, which language shall be controlling and any revision of this Agreement in any other language shall not be binding. Both parties agree that this Agreement is the complete and exclusive statement of the mutual understanding of the parties relating to the subject matter of this Agreement. BCI reserves the right at any time to modify this Agreement in its sole discretion, without liability to You. This Agreement, as amended, will be effective upon use of the BCI Products, or Software and effective for all existing users immediately after posting of any amended terms on the BCI website.

Open Source Software Notice

This document is valid for open-source components used in the following BCI Product:

BECKMAN COULTER DxC 700 AU

Please be informed that the Software contains the following third-party components:

Table C.1 Table 1

No.	License	Component	Notes
1	Jam STAPL Software License	Jam STAPL Byte-Code Player, Version 2.2, Module: jbicomp.c	Copyright (C) Altera Corporation 1997-2001.
		Jam STAPL Byte-Code Player, Version 2.2, Module: jbicomp.h	Copyright (C) Altera Corporation 1997-2001.
		Jam STAPL Byte-Code Player, Version 2.2, Module: jbiexprt.h	Copyright (C) Altera Corporation 1998-2001.
		Jam STAPL Byte-Code Player, Version 2.2, Module: jbijtag.c	Copyright (C) Altera Corporation 1998-2001.
		Jam STAPL Byte-Code Player, Version 2.2, Module: jbijtag.h	Copyright (C) Altera Corporation 1998-2001.
		Jam STAPL Byte-Code Player, Version 2.2, Module: jbimain.c	Copyright (C) Altera Corporation 1998-2001.
		Jam STAPL Byte-Code Player, Version 2.2, Module: jbiport.h	Copyright (C) Altera Corporation 2000-2001.
		Jam STAPL Byte-Code Player, Version 2.2, Module: jbistub.c	Copyright (C) Altera Corporation 1997-2001.

License:

1) Jam STAPL Software License

SOFTWARE DISTRIBUTION AGREEMENT

THE JAM SOFTWARE PROGRAM AND EXECUTABLE FILES, AND RELATED SPECIFICATION DOCUMENTATION ("PROGRAMS") (AVAILABLE FOR DOWNLOADING FROM THIS WEB SITE OR ENCLOSED WITH THE COMPUTER DISK ACCOMPANYING THIS NOTICE), ARE MADE FREELY AVAILABLE FOR USE BY ANYONE, SUBJECT TO CERTAIN TERMS AND CONDITIONS SET FORTH BELOW. PLEASE READ THESE TERMS AND CONDITIONS CAREFULLY BEFORE DOWNLOADING OR USING THE PROGRAMS. BY DOWNLOADING OR USING THE PROGRAMS YOU INDICATE YOUR ACCEPTANCE OF THESE TERMS AND CONDITIONS, WHICH CONSTITUTE THE LICENSE AGREEMENT (the "AGREEMENT") BETWEEN YOU AND ALTERA CORPORATION ("ALTERA") WITH REGARD TO THE PROGRAMS. IN THE EVENT THAT YOU DO NOT AGREE WITH ANY OF THESE TERMS AND CONDITIONS, DO NOT DOWNLOAD THE PROGRAMS OR PROMPTLY RETURN THE PROGRAMS TO ALTERA UNUSED.

1. License Terms

Subject to the terms and conditions of this Agreement, Altera grants to you a worldwide, nonexclusive, perpetual license (with the right to grant sublicenses, and authorize sublicensees to sublicense further) to use, copy, prepare derivative works based on, and distribute the Programs and derivative works thereof, provided that any distribution or sublicense is subject to the same terms and conditions that you use for distribution of your own comparable software products. Any copies of the Programs or derivative works thereof will continue to be subject to the terms and conditions of this Agreement. You must include in any copies of the Programs or derivative works thereof any trademark, copyright, and other proprietary rights notices included in the Programs by Altera.

2. Disclaimer of Warranties and Remedies

NO WARRANTIES, EITHER EXPRESS OR IMPLIED, ARE MADE WITH RESPECT TO THE PROGRAMS, INCLUDING, BUT NOT LIMITED TO, IMPLIED WARRANTIES OF MERCHANTABILITY, FITNESS FOR A PARTICULAR PURPOSE, TITLE AND NONINFRINGEMENT, AND ALTERA EXPRESSLY DISCLAIM ALL WARRANTIES NOT STATED HEREIN. YOU ASSUME THE ENTIRE RISK AS TO THE QUALITY, USE, AND PERFORMANCE OF THE PROGRAMS. SHOULD THE PROGRAMS PROVE DEFECTIVE OR FAIL TO PERFORM PROPERLY, YOU -- AND NOT ALTERA -- SHALL ASSUME THE ENTIRE COST AND RISK OF ANY REPAIR, SERVICE, CORRECTION, OR ANY OTHER LIABILITY OR DAMAGES CAUSED BY OR OTHERWISE ASSOCIATED WITH THE PROGRAMS. ALTERA DOES NOT WARRANT THAT THE PROGRAMS WILL MEET YOUR REQUIREMENTS, OR THAT THE OPERATION OF THE PROGRAMS WILL BE UNINTERRUPTED OR ERROR-FREE. YOU ALSO ASSUME RESPONSIBILITY FOR THE SELECTION, INSTALLATION, USE, AND RESULTS OF USING THE PROGRAMS. Some states do not allow the exclusion of implied warranties, so the above exclusion may not apply to you.

ALTERA SHALL NOT BE LIABLE TO YOU OR ANY OTHER PERSON FOR ANY DAMAGES, INCLUDING ANY INCIDENTAL OR CONSEQUENTIAL DAMAGES, EXPENSES, LOST PROFITS, LOST SAVINGS, OR OTHER DAMAGES ARISING OUT OF OR OTHERWISE ASSOCIATED WITH THE USE OF OR INABILITY TO USE THE

PROGRAMS. IN ANY EVENT, ALTERA'S LIABILITY UNDER THIS AGREEMENT SHALL NOT EXCEED THE LARGER OF EITHER THE AMOUNT YOU PAID ALTERA FOR USE OF THE PROGRAMS, OR ONE HUNDRED DOLLARS (\$100). YOUR SOLE REMEDIES AND ALTERA'S ENTIRE LIABILITY ARE AS SET FORTH ABOVE. Some states do not allow the limitation or exclusion of incidental or consequential damages, so the above limitations or exclusions may not apply to you.

To the extent that the Programs are derived from third-party software or other third-party materials, no such third-party provides any warranties with respect to the Programs, assumes any liability regarding use of the Programs, or undertakes to furnish you any support or information relating to the Programs.

3. General

You acknowledge that Altera is not responsible for and is not obligated to provide, any support, including email and telephone support, for any purpose with respect to the Programs.

You acknowledge that the Programs are made freely available in accordance with this Agreement as part of an effort to promote broad use of the Programs with minimum interference by you and Altera. Accordingly, you agree that, if you obtain any patents relating to inventions or discoveries made through use of or access to the Programs or derivative works thereof, or that are necessary for the use of the Programs, you will not bring any claim for infringement thereof against Altera or any direct or indirect licensee of Altera in connection with or use of the Programs or derivative works thereof. The foregoing does not constitute a license of any copyright or trade secret.

You shall not export the Programs, or any product programmed by the Programs, without first obtaining any necessary U.S. or other governmental licenses and approvals.

This Agreement is entered into for the benefit of Altera and Altera's licensors and all rights granted to you and all obligations owed to Altera shall be enforceable by Altera and its licensors. This Agreement constitutes the entire understanding and agreement applicable to the Programs, superseding any prior or contemporaneous understandings or agreements. It may not be modified except in a writing executed by Altera.

This Agreement will be governed by the laws of the State of California. You agree to submit to the jurisdiction of the courts in the State of California for the resolution of any dispute or claim arising out of or relating to this Agreement.

The prevailing party in any legal action or arbitration arising out of this Agreement shall be entitled to reimbursement for its expenses, including court costs and reasonable attorneys' fees, in addition to any other rights and remedies such party may have.

BY USING THE PROGRAMS YOU ACKNOWLEDGE THAT YOU HAVE READ THIS AGREEMENT, UNDERSTAND IT, AND AGREE TO BE BOUND BY ITS TERMS AND CONDITIONS; YOU FURTHER AGREE THAT IT IS THE COMPLETE AND EXCLUSIVE STATEMENT OF THE AGREEMENT BETWEEN YOU AND ALTERA WHICH SUPERSEDES ANY PROPOSAL OR PRIOR AGREEMENT, ORAL OR WRITTEN, AND ANY OTHER COMMUNICATIONS BETWEEN YOU AND ALTERA RELATING TO THE SUBJECT MATTER OF THIS AGREEMENT.

4. U.S. Government Restricted Rights

The Programs and any accompanying documentation are provided with RESTRICTED RIGHTS. Use, duplication, or disclosure by the Government is subject to restrictions as set forth in subparagraph (c)(1)(ii) of The Rights in Technical Data and Computer Software clause at DFARS 252.227-7013 or subparagraphs (c)(1) and (2) of Commercial Computer Software--Restricted Rights at 48 CFR 52.227-19, as applicable. Contractor/manufacturer is Altera Corporation, 101 Innovation Drive, San Jose, CA 95134 and its licensors.

End-User License Agreement and Open Source Software Notice

Open Source Software Notice

www.beckmancoulter.com



© 2021 Beckman Coulter, Inc.
All Rights Reserved.