

Instructions for Use

StatSpin Express 4 Centrifuge Model Number M510

This manual is intended for

SSH4 – StatSpin Express 4 for 100-240 VAC, 50/60 Hz

Instructions for Use**StatSpin Express 4 Centrifuge Model Number M510**

PN 55-006276-001CE (August 2025)

© 2025 Beckman Coulter, Inc.
All Rights Reserved.

Trademarks

Beckman Coulter, the stylized logo, and the Beckman Coulter product and service marks mentioned herein are trademarks or registered trademarks of Beckman Coulter, Inc. in the United States and other countries.

All other trademarks are the property of their respective owners.

May be covered by one or more patents – see www.beckmancoulter.com/patents.

Find us on the World Wide Web at:

www.beckmancoulter.com

Original Instructions

Revision History 55-006276-001

CE (August, 2025)

- Removed Limited Warranty

CD (December, 2021)

- Added: Product Description section
- Updated the following:
 - Copyright page
 - Symbols and Definitions
 - Safety Notices Warning and Cautions throughout
 - Accessories
 - Confirming the Contents
 - Cycle Selection
 - Error Indicators
 - Installing the System
 - Intended Use
 - Limited Warranty and Disclaimer sections
 - Periodic Maintenance Check
 - Specifications
 - Spinning the Sample
 - Troubleshooting

CC (September, 2018)

- Deleted: StatSpin registered trademark, and references to IRIS

CB (March, 2018)

- Converted the StatSpin Express 4 Operations Manual to a Beckman Coulter Instructions for Use (IFU) Manual, and made general clarifications to the IFU
- Added: Revision History, Safety Notice, Symbols and Definitions table, Alerts for Warning, Caution, Important, Note, and Tip explanations, Warning and Cautions, and How to Replace the Fuse
- Updated: Logo, Manufacturer address, Intended Use, and Limited Warranty statement
- Deleted: EC Rep

Safety Notice

Read all product manuals and consult with Beckman Coulter-trained personnel before you operate the system. Do not perform any procedure before you carefully read all instructions. Always follow the product labels and the manufacturer's recommendations. If you have any questions:

- Visit <http://www.beckmancoulter.com>.
- US customers: Contact Beckman Coulter Customer Support at 1-800-854-3633.
- International customers: Contact your local distributor.

Alerts for Warning, Caution, Important, Note, and Tip



Warning indicates a potentially hazardous situation which can cause death or serious injury. Warning can indicate the possibility of erroneous data that could cause an incorrect diagnosis.



Caution indicates a potentially hazardous situation which can cause minor or moderate injury. Caution can also alert against unsafe practices, or indicate the possibility of erroneous data that could cause an incorrect diagnosis.



Important indicates important information to follow.

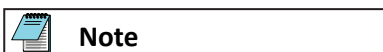

Note indicates notable information to follow.

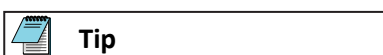

Tip indicates information to consider.

Safety Notice

Warnings and Cautions

Warnings and Cautions

Pay close attention to the instructions that accompany the notes and symbols and the standard laboratory procedures outlined by your facility and local regulatory agencies.



Warning

Always operate the system with shield and cover in position and secured to avoid injury.

Perform system operations with caution.

Wear Personal Protective Equipment (PPE) such as gloves, eye shields, and lab coats.

Wash hands thoroughly after contact with sample media and all maintenance activities.

Observe all laboratory policies and procedures related to the handling of biohazardous materials.

Refer to the applicable sources (such as Safety Data Sheets) for specific hazard information.



Warning

Do not operate the centrifuge below the minimum operating temperature (2°C). Do not store the rotor below the minimum storage temperature. Doing so will subject the rotor materials to damage. Refer to [Specifications](#).



Warning

Do not expose the rotor to strong or concentrated acids, bases, esters, aromatic or halogenated hydrocarbons, ketones, or strong oxidizing agents, or environmental influences, including natural ultra-violet radiation. Doing so will subject the rotor to corrosion or weakening of the construction.



Warning

Handle and dispose of sharp fragments according to the World Health Organization's Laboratory Biosafety Manual and relevant local and national regulations.



Warning

Safety protection may be impaired if the equipment is used in a manner not specified by the manufacturer.

 **Warning**

Inspect the instrument for cracks or any physical damage to housing, cover, and rotor upon the receipt of the unit. Damage can cause unsafe operation; if damage or cracks are found, discontinue use until repairs have been performed.

 **Warning**

Only reset the cycle counter after conducting the recommended inspections and service. Resetting the cycle counter without performing the recommended inspections and service reduces the reliability and safety of the instrument.

 **Warning**

Outside of North America: do not use the power cord supplied. Use power cord for at least 3.0 Amp with an IEC320/CEE22 female connector and male connector suitable for the power outlet to be used.

 **Warning**

Picking up or moving the centrifuge during operation can cause injury to the operator and/or damage to the centrifuge.

 **Warning**

Electromagnetic Compatibility

This device complies with the emissions and immunity requirements as specified in the EN/IEC 61326 series of Product Family Standards for a “basic electromagnetic environment.” Such equipment is supplied directly at low voltage from public mains network. This equipment is not intended for residential use.

This device generates, uses, and can radiate unintentional radio-frequency (RF) energy. If this device is not installed and operated correctly, this RF energy can cause interference with other equipment. It is the responsibility of the end user to be sure that a compatible electromagnetic environment for the device can be maintained so that the device operates as intended.

This equipment is designed for use in a PROFESSIONAL HEALTHCARE FACILITY ENVIRONMENT. It is likely to perform incorrectly if used in a HOME HEALTHCARE ENVIRONMENT. If it is suspected that performance is affected by electromagnetic

Safety Notice

Warnings and Cautions

interference, correct operation may be restored by increasing the distance between the equipment and the source of the interference.

In addition, other equipment can radiate RF energy to which this device is sensitive. If one suspects interference between this device and other equipment, Beckman Coulter recommends the following actions to correct the interference:

- Evaluate the electromagnetic environment before installation and operation of this device.
- Do not operate this device close to sources of strong electromagnetic radiation (for example: unshielded intentional RF sources), as these can interfere with proper operation. Examples of unshielded intentional radiators are handheld radio transmitters, cordless phones, and cellular phones.
- Do not place this device near medical electrical equipment that can be susceptible to malfunctions caused by close-proximity to electromagnetic fields.
- This device has been designed and tested to CISPR 11, Class A emission limits. In a domestic environment, this device can cause radio interference, in which case, you need to take measures to mitigate the interference.

 **Caution**

Disconnect the power cord from the electrical outlet before performing maintenance or inspection.

 **Caution**

Do not spray cleaning solutions directly onto the centrifuge bowl or housing. Overspray can reach the motor bearings or internal circuitry, causing harm to the electronics and could also cause corrosion or weakening of the construction of the protective casing.

Before using any cleaning or decontamination methods other than those recommended by the manufacturer, users should check with the manufacturer that the proposed method will not damage the equipment. Cleaning and decontamination may be necessary as a safeguard before laboratory centrifuges, rotors, and any accessories are maintained repaired, or transferred.

 **Caution**

During operation maintain a 30 cm (12 inch) clearance around the centrifuge. The clearance must be free from obstruction and away from the edge of the surface that the centrifuge is on. The appliance coupler on the rear of the instrument is considered the power supply disconnect device, ensure that it is accessible after installation.

 **Caution**

Follow Universal Precautions with all biological specimens, regardless of whether the specimen is known to contain an infectious agent. (See [References](#))

 **Caution**

Use the same size and style tubes in opposite positions. Balance liquid in tubes to within 0.5mL. If glass tubes are used to balance rotor load, replace the glass balance tube every ten cycles to prevent possible breakage caused by the repeated stress of centrifugation. Replace the tube inserts immediately if a tube breaks during centrifugation.

 **Caution**

Inspect rotor on a routine basis. Rotor lifespan depends on usage. Inspect rotor for cracks and replace the rotor immediately when any crack or visible wear occurs.

 **Caution**

Never operate the centrifuge without the rotor properly mounted and the hex screw tightened. Failure to install and secure the rotor correctly can damage the centrifuge.

 **Caution**

Replace Tube Insert immediately if a tube breaks during centrifugation. Wear Personal Protective Equipment (PPE) such as gloves, eye shields, and lab coats.

 **Caution**

Running the centrifuge repeatedly with an unbalanced load condition can cause excessive vibrations and premature equipment failure.

 **Caution**

The cover interlock bypass is for emergency use only. Disconnect the power cord from the wall outlet and ensure the rotor has come to a complete stop before using the interlock bypass. If the equipment is not used correctly, safety can be impaired.

 **Caution**

The instructions prohibit use of the specified materials within the centrifuge

- flammable or explosive materials.
- materials which could react chemically with sufficient vigor to cause a hazard.

 **Caution**

Ensure to replace the fuse with the correct type and rating for continued protection against risk of fire and/or improper instrument operation.

Safety Notice

Symbols and Definitions



If the fuse continues to blow after being replaced, contact service for additional assistance.

Please use the instrument as intended. Improper use may cause damage to the instrument, inaccurate results, or potentially nullify warranties.

Symbols and Definitions

Table 1 Express 4 Symbols Glossary



Symbol	Description
	<p>Warning; Biological hazard</p> <p>This symbol indicates a warning of a biological hazard.</p> <p><i>ISO 7010. Graphical Symbols - Safety colors and safety signs. #W009</i></p> <p>Supplemental Product-Specific Manufacturer Information</p> <p>This symbol indicates a caution to operate only with all covers in position to decrease risk of personal injury or biohazard.</p> <p>This symbol indicates the use of biohazardous materials in the area. Use caution when working with possible infectious samples.</p> <p>Wear Personal Protective Equipment (PPE) such as gloves, eye shields, and lab coats. Handle and dispose of biohazardous materials according to your laboratory procedures.</p>
	<p>Consult instructions for use</p> <p>This symbol indicates the need for the user to consult the instructions for use.</p> <p><i>ISO 15223-1. Medical devices - Symbols to be used with medical device labels, labelling and information to be supplied - Part 1: General Requirements. #5.4.3</i></p>
	<p>Caution</p> <p>This symbol indicates the need for the user to consult the instructions for use for important cautionary information such as warnings and precautions that cannot, for a variety of reasons, be presented on the medical device itself.</p> <p><i>ISO 15223-1. Medical devices - Symbols to be used with medical device labels, labelling and information to be supplied - Part 1: General Requirements. #5.4.4</i></p>

Table 1 Express 4 Symbols Glossary (Continued)





Symbol	Description
	<p>Warning; Crushing of hands</p> <p>This symbol indicates a warning of a closing motion of mechanical parts of equipment.</p> <p><i>ISO 7010. Graphical Symbols for electrical equipment in medical practices. #W024</i></p> <p>Supplemental Product-Specific Manufacturer Information</p> <p>Use caution to avoid injury to hands when close to equipment with moving mechanical parts.</p>
	<p>Moving Parts Symbol</p> <p>This symbol indicates that there are moving parts in the area. Only operate the system when all covers are in position and use caution to reduce the risk of personal injury. While the system is operating, do not touch the moving parts of the system. Do not insert fingers or hands into any system opening.</p>
	<p>cNRTLus Certification Mark</p> <p>This symbol indicates recognition by a Nationally Recognized Testing Laboratory (NRTL) that the system has met the relevant product safety standards for the United States and Canada.</p> <p><i>OSHA, CEC</i></p>
	<p>RCM Symbol</p> <p>This symbol indicates compliance with the Australian Communications Media Authority (ACMA) requirements (safety and EMC) for Australia and New Zealand.</p>

Table 1 Express 4 Symbols Glossary (Continued)







Symbol	Description
	<p>Recycling Symbol</p> <p>This symbol is required by the Waste Electrical and Electronic Equipment (WEEE) Directive of the European Union. This symbol indicates that:</p> <ol style="list-style-type: none"> 1. The device was put on the European Market after August 13, 2005. 2. The device is not to be disposed of via the municipal waste collection system of any member state of the European Union. <p>Customers must understand and follow all laws regarding the correct decontamination and safe disposal of electrical equipment. For Beckman Coulter products bearing this label, contact your dealer or your local Beckman Coulter Representative for more information on the take-back program that facilitates the correct collection, treatment, recovery, recycling, and safe disposal of these products.</p> <p><i>EU Directive 2002-96-EC: waste electrical and electronic equipment (WEEE)</i></p> <p>For the Japan market:</p> <p>This system is considered an industrial waste, subject to special controls for infectious waste. Before disposal of the system, refer to the <i>Waste Disposal and Public Cleaning Law</i> for compliance procedures.</p>
	<p>RoHS Caution Symbol</p> <p>This symbol indicates that this electronic information product contains certain toxic or hazardous elements, and can be used safely during its environmental protection use period. The number in the middle of the logo indicates the environmental protection use period (in years) for the product. The outer circle indicates that the product can be recycled. The logo also signifies that the product should be recycled immediately after its environmental protection use period has expired. The date on the label indicates the date of manufacture.</p> <p>These labels and materials declaration table (the Table of Hazardous Substance's Name and Concentration) meet People's Republic of China Electronic Industry Standard SJ/T11364-2006 <i>Marking for Control of Pollution Caused by Electronic Information Products</i> requirements.</p>
	<p>"OFF" (power)</p> <p>This symbol indicates disconnection from the mains, at least for mains switches or their positions, and all those cases where safety is involved.</p> <p><i>IEC 60417: Graphical symbols for use on equipment - Overview and application, #5008</i></p> <p>Supplemental Product-Specific Manufacturer Information</p> <p>This symbol indicates the off position.</p>

Table 1 Express 4 Symbols Glossary (Continued)

Symbol	Description
	<p>"ON" (power)</p> <p>This symbol indicates connection to the mains, at least for mains switches or their positions, and all those cases where safety is involved.</p> <p><i>IEC 60417: Graphical symbols for use on equipment - Overview and application, #5007</i></p> <p>Supplemental Product-Specific Manufacturer Information</p> <p>This symbol indicates the on position.</p>
	<p>Alternating current</p> <p>This symbol indicates on the rating plate that the equipment is suitable for alternating current only; to identify relevant terminals.</p> <p><i>IEC 60417: Graphical symbols for use on equipment - Overview and application, #5032</i></p>
	<p>Fuse</p> <p>This symbol indicates fuse boxes or their location.</p> <p><i>IEC 60417: Graphical symbols for use on equipment - Overview and application, #5016</i></p> <p>Supplemental Product-Specific Manufacturer Information</p> <p>This symbol can also indicate a fuse location and rating.</p>
	<p>Protective earth; protective ground</p> <p>This symbol indicates a terminal which is intended for connection to an external conductor for protection against electric shock in case of a fault, or the terminal of a protective earth (ground) electrode.</p> <p><i>IEC 60417: Graphical symbols for use on equipment - Overview and application, #5019</i></p>
	<p>Date of Manufacture</p> <p>This symbol indicates the date when the medical device was manufactured.</p> <p><i>ISO 15223-1. Medical devices - Symbols to be used with medical device labels, labelling and information to be supplied - Part 1: General Requirements. #5.1.3</i></p>

Safety Notice
 Symbols and Definitions

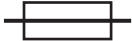
Table 1 Express 4 Symbols Glossary (Continued)













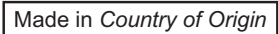

Symbol	Description
	<p>Manufacturer</p> <p>This symbol indicates the medical device manufacturer.</p> <p><i>ISO 15223-1. Medical devices - Symbols to be used with medical device labels, labelling and information to be supplied - Part 1: General Requirements. #5.1.1</i></p> <p>Supplemental Product-Specific Manufacturer Information</p> <p>This symbol indicates who the legal manufacturer of the product is.</p>
	<p>Catalogue Number</p> <p>This symbol indicates the manufacturer's catalogue number so that the medical device can be identified.</p> <p><i>ISO 15223-1. Medical devices - Symbols to be used with medical device labels, labelling and information to be supplied - Part 1: General Requirements. #5.1.6</i></p>
	<p>Serial number</p> <p>This symbol indicates the manufacturer's serial number so that a specific medical device can be identified.</p> <p><i>ISO 15223-1. Medical devices - Symbols to be used with medical device labels, labelling and information to be supplied - Part 1: General Requirements. #5.1.7</i></p>
	<p>Country of Origin Symbol</p> <p>This symbol indicates the country that the product was manufactured in.</p>
	<p>California Proposition 65</p> <p>This symbol indicates that this product can expose you to chemicals known to the State of California to cause Cancer and Reproductive Harm. For more information go to https://www.P65Warnings.ca.gov.</p>
	<p>Batch Code</p> <p>Indicates product lot number.</p>
	<p>Do Not Reuse</p> <p>Indicates product is single use only.</p>
	<p>Use By Date</p> <p>Indicates product expiration date.</p>

Table 1 Express 4 Symbols Glossary (Continued)

Symbol	Description
	Contents Indicates project contents.
	Non-sterile Indicates non-sterile product.
	Temperature limitation Indicates storage requirements limit.
	Start button The Start button initiates the selected cycle.
	Stop or Open button The Stop or Open button interrupts the cycle and stops the centrifugation. This button releases the cover.
	Error or Service indicator The red indicator with an adjacent wrench symbol flashes to signal an error condition or remains continuously illuminated when service is needed.
	Lock Locked position for shield.
	Unlock Unlocked position for shield.

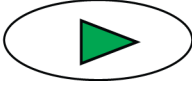
Safety Notice

Symbols and Definitions

Contents

	Revision History 55-006276-001, iii
	Safety Notice, v
CHAPTER 1:	Installation, 1-1
	Inspecting the Package, 1-1
	Confirming the Contents, 1-1
	Installing the System, 1-1
	Connecting the Power, 1-2
CHAPTER 2:	System Overview, 2-1
	Intended Use, 2-1
	Product Description, 2-1
	Operator Controls, 2-1
	Error Indicators, 2-2
	Error Code Table, 2-3
	Accessories, 2-4
CHAPTER 3:	Operating Instructions, 3-1
	Opening and Closing the Cover, 3-1
	Cover Interlock By-pass, 3-1
	Removing and Installing the Rotor, 3-1
	Removing the Rotor, 3-1
	Reinstalling the Rotor, 3-2
	Spinning the Sample, 3-3
	Loading, 3-3
	Cycle Selection, 3-5
	Unloading, 3-5
CHAPTER 4:	Maintenance, 4-1
	Overview, 4-1
	Cleaning, 4-1
	General Cleaning, 4-2
	Disinfecting the Rotor, 4-2
	Checking the Rotor Speed, 4-2
	Inspecting the Rotor, 4-3
	Periodic Maintenance Check, 4-3
	Resetting the Cycle Counter, 4-4
	Troubleshooting, 4-4
	Replacing the Fuse, 4-5
	Service, 4-6
APPENDIX A:	Specifications, A-1
	Specifications, A-1

Contents

APPENDIX B:	References, B-1
	References, B-1

Inspecting the Package

The StatSpin Express 4 and its accessories are delivered in one carton. If the centrifuge or accessories have suffered any damage in transport, inform your carrier immediately.



Note

Save shipping carton and components to simplify return if service is required.

Confirming the Contents

The package contains:

- One StatSpin Express 4 horizontal centrifuge (Product No. SSH4)
- One centrifuge rotor (Product No. RTH8)
- Eight tube inserts for 13x100 mm tubes (Product No. SV09)
- Eight tube inserts for 16x100 mm tubes (Product No. SV07)
- One line cord for use in North America only.
- One Instructions for Use Manual
- One manual latch release tool
- One 1/8 inch hex key

Installing the System

- 1 Place the centrifuge on a solid level surface suitable for operation of laboratory instrumentation.



Caution

During operation maintain a 30 cm (12 inch) clearance around the centrifuge. The clearance must be free from obstruction and away from the edge of the surface that the centrifuge is on. The appliance coupler on the rear of the instrument is considered the power supply disconnect device, ensure that it is accessible after installation.

- 2 Position the StatSpin Express 4 away from direct sunlight and sources of heat or cold.
- 3 For the acceptable range of operating temperature and humidity, refer to [Specifications](#).
- 4 Remove the packaging around the rotor and in the cover before operating the centrifuge.

Installation

Connecting the Power

Connecting the Power

- 1 Plug the centrifuge into a grounded outlet supplying 100-240 V @ 50-60 Hz.
- 2 Turn on the power switch (located on the rear panel, above the line cord connector).
- 3 When the instrument is ready for use, it will give a two beep signal and illuminate the two minute cycle light on the front keypad. Press the stop button to release the latch and open the cover.



Warning

Outside of North America: do not use the power cord supplied. Use power cord for at least 3.0 Amp with an IEC320/CEE22 female connector and male connector suitable for the power outlet to be used.

Intended Use





The StatSpin Express 4 is a high-speed horizontal bench top centrifuge used to rapidly separate whole blood in the original sample collection tubes. Do not centrifuge substances with a density greater than 1.2 kg/dm³.

Product Description

The horizontal rotor included with the centrifuge accepts up to 8 primary 16x100mm primary blood tubes with a maximum volume of 10 mL per tube. The operator selects a fixed spin time of 3, 5 or 10 minutes. The rotation speed is 5100 rpm for the 3 and 5 minute cycles, producing a centrifugal force of 4000 xg at a rotor radius of 13.8 cm. The 10 minute cycle generates 3100 xg at 4500 rpm. This setting provides lower g-forces for procedures which require a conventional spin.

Operator Controls

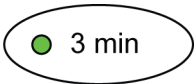
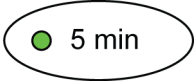

Table 2 Express 4 Operator Controls

Symbol	Description
	Start button The Start button initiates the selected cycle.
	Stop or Open button The Stop or Open button interrupts the cycle and stops the centrifugation. This button releases the cover.
	3 Minute Cycle The 3 min button selects a cycle of three minutes at 5100 rpm.
	5 Minute Cycle The 5 min button selects a cycle of five minutes at 5100 rpm.
	10 Minute Cycle The 10 min button selects a cycle of ten minutes at 4500 rpm.
	Error or Service indicator The red indicator with an adjacent wrench symbol flashes to signal an error condition or remains continuously illuminated when service is needed.

System Overview

Error Indicators

Table 2 Express 4 Operator Controls (Continued)

Symbol	Description
	Lock Locked position for shield.
	Unlock Unlocked position for shield.



Note

Buttons should be depressed with finger tips only. Never press buttons with a sharp object such as a pen, screwdriver, centrifuge insert, fingernail, etc. The buttons are membrane switches designed to be activated by finger actuation. Use with any hard or sharp object can cause damage to the tactile layer of the button, rendering the button unstable and prone to premature failure.

Error Indicators

A flashing red Error or Service indicator on the control panel signals a StatSpin Express 4 error condition.

Use the combination of green cycle time indicators that are flashing to identify the cause of the error condition. For more information, refer to [Error Code Table](#).

To clear the error condition, correct the problem and press the Stop or Open button.

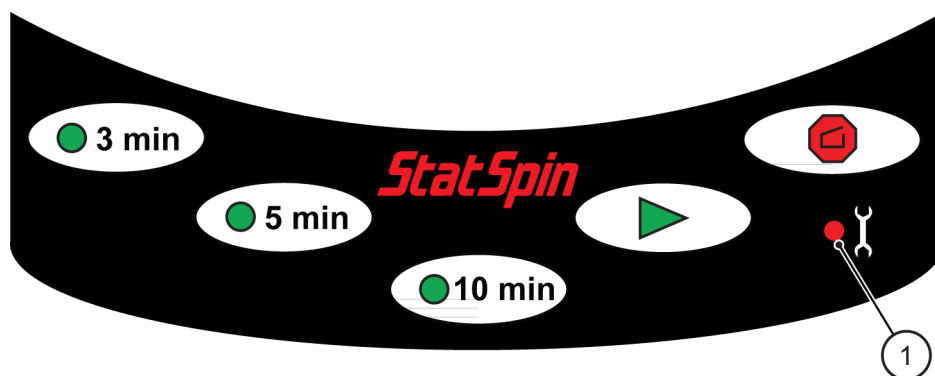

1. Error or Service light flashing

Error Code Table

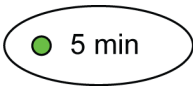
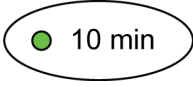
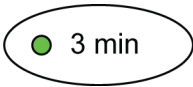
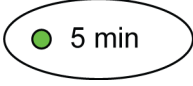
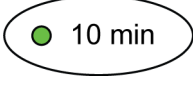

Table 3 Error Code Table

Cycle Time Indicator Combination	Problem	Solution
● 3 min	Failure to reach speed in 30 seconds.	Confirm no obstruction in bowl area, contact customer service.
● 5 min	Latch is not locked.	Confirm cover is fully seated in closed position.
● 3 min ● 5 min	Rotor exceeded set speed.	Remove and inspect rotor, reinstall.
● 10 min	Cover is not closed.	Confirm cover is fully seated in closed position.
● 3 min ● 10 min	Out of balance.	Confirm tubes are balanced in rotor and centrifuge is on a level surface.

System Overview

Accessories

Table 3 Error Code Table (Continued)

Cycle Time Indicator Combination	Problem	Solution
 	Locked Rotor	Contact customer service. Confirm no obstruction in bowl area.
  	Shield is not installed.	Confirm shield is installed and in the locked position.
Continuously illuminated Error or Service indicator. 	Cycle Counter	50,000 run cycles have been reached, please conduct periodic maintenance check. (For more information, refer to Maintenance).

Accessories

Table 4 Accessories

Product No.	Description
SV02	Inserts for 3 mL tubes (10.25 x 64 mm) 4/pk.
SV05	Inserts for 1.5 - 2.0 mL microtubes (10.25 x 47 mm or BD Microtainers) 4/pk.
SV06	Inserts for 7 mL tubes (16 x 75 mm) 8/pk.
SV07	Inserts for 10 mL tubes (16 x 100 mm) 8/pk. Included with centrifuge
SV08	Inserts for 5 mL tubes (13 x 75 mm) 8/pk.
SV09	Inserts for 7 mL tubes (13 x 100 mm) 8/pk. Included with centrifuge
SV10	Inserts for 5 mL Greiner tubes (13 x 75 mm) 8/pk.
SV11	Inserts for 4 mL BD RST tubes (13 x 100 mm) 8/pk
RTH8	8 place rotor. Included with centrifuge

Figure 1 StatSpin Express 4 Tube Insert Guide

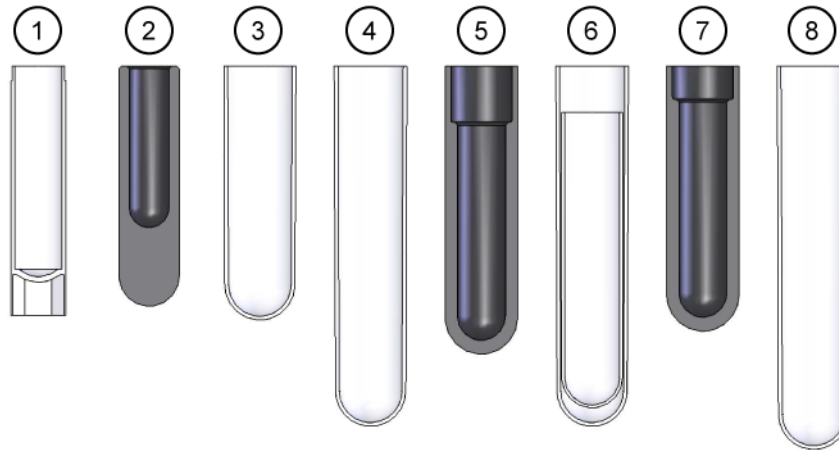

- | | |
|--|----------------------------------|
| 1. SV02 10.25 x 64 mm | 5. SV08 13 x 75 mm BD tubes |
| 2. SV05 1.5-2.0 mL microtubes, 10.25 x 47 mm, and BD Microtainers® | 6. SV09 13 x 100 mm |
| 3. SV06 16 x 75 mm | 7. SV10 13 x 75 mm Greiner tubes |
| 4. SV07 16 x 100 mm | 8. SV11 13 x 100 mm BD RST tubes |

System Overview

Accessories

Opening and Closing the Cover

The electronically operated cover interlock mechanism prevents operation until the cover is completely closed and locked, and prevents the cover from being opened while the centrifuge is in operation. When the cover is completely closed and locked, an operating cycle can be initiated.

Cover Interlock By-pass

To release the electronically operated cover interlock mechanism, insert the manual latch release tool into the small hole in the center of the front membrane panel. If you press the **Stop** or **Open** button and the cover does not release, push the lock lever inward about one inch (25 mm) to release the interlock mechanism. The cover interlock by-pass is for emergency use only. Misuse may expose the operator to unsafe conditions.



The cover interlock bypass is for emergency use only. Disconnect the power cord from the wall outlet and ensure the rotor has come to a complete stop before using the interlock bypass. If the equipment is not used correctly, safety can be impaired.

Removing and Installing the Rotor

The Express 4 is shipped with the rotor installed and supported by a shipping retainer. To prevent possible damage to the motor mount of the centrifuge, remove the rotor whenever the centrifuge is shipped to another location.



Never operate the centrifuge without the rotor properly mounted and the hex screw tightened. Failure to install and secure the rotor correctly can damage the centrifuge.

Removing the Rotor

-
- 1 Open the cover.

 - 2 Turn off the power.

 - 3 Disconnect the power cord.

Operating Instructions

Removing and Installing the Rotor

-
- 4 Remove the shield. Grasp the shield at the center opening and rotate clockwise to unlock. Lift the shield straight up and out of the centrifuge housing.

Figure 2 Removing Shield



1. Remove the shield by lifting it straight up and out of the centrifuge.

Figure 3 Locking Shield

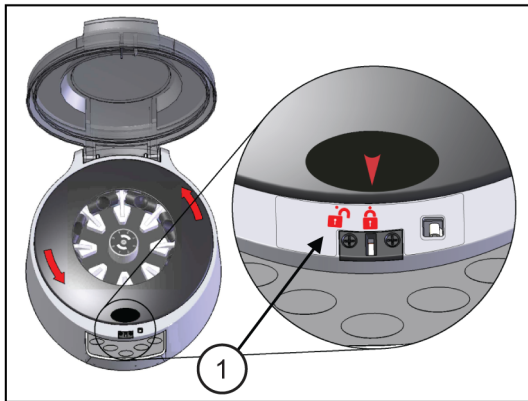

1. Locked and Unlocked Positions

-
- 5 Use an 1/8 inch hex key to remove the hex screw of the rotor hub.
 - 6 Remove the rotor by lifting it straight up and out of the centrifuge.
-

Reinstalling the Rotor

-
- 1 Align the indent on the side of the rotor hub with the flat on the motor shaft.
 - 2 Slide the rotor onto the motor shaft to seat. Do not force the rotor onto the motor shaft. If it does not slide down easily re-align the rotor with the motor shaft.
-

-
- 3 Reinstall hex screw and tighten with 1/8 hex key (supplied).
-
- 4 Reinstall the shield into the housing by grasping the shield in the center and rotating it counter-clockwise until it is in the locked position.
-

Spinning the Sample

Loading



Warning

Always operate the system with shield and cover in position and secured to avoid injury.

Perform system operations with caution.

Wear Personal Protective Equipment (PPE) such as gloves, eye shields, and lab coats.

Wash hands thoroughly after contact with sample media and all maintenance activities.

Observe all laboratory policies and procedures related to the handling of biohazardous materials.

Refer to the applicable sources (such as Safety Data Sheets) for specific hazard information.



Caution

Never operate the centrifuge without the rotor properly mounted and the hex screw tightened. Failure to install and secure the rotor correctly can damage the centrifuge.



Caution

During operation maintain a 30 cm (12 inch) clearance around the centrifuge. The clearance must be free from obstruction and away from the edge of the surface that the centrifuge is on. The appliance coupler on the rear of the instrument is considered the power supply disconnect device, ensure that it is accessible after installation.

-
- 1 Be sure the correct tube inserts are installed. The StatSpin Express 4 centrifuge is provided with eight tube inserts for 13 x 100-mm tubes (Product No. SV09) and eight

Operating Instructions

Spinning the Sample

tube inserts for 16 x 100-mm tubes (Product No. SV07). Other sizes are available (Refer to [Accessories](#)).

- 2 The rotor must be balanced to ensure smooth operation. Do not spin a single tube.



Running the centrifuge repeatedly with an unbalanced load condition can cause excessive vibrations and premature equipment failure.

- 3 Use the same size and style tubes in opposite positions of the sample. Fill the balance tube with liquid to within 0.5 mL.



Handle and dispose of sharp fragments according to the World Health Organization's Laboratory Biosafety Manual and relevant local and national regulations.



Replace Tube Insert immediately if a tube breaks during centrifugation. Wear Personal Protective Equipment (PPE) such as gloves, eye shields, and lab coats.



Use the same size and style tubes in opposite positions. Balance liquid in tubes to within 0.5mL. If glass tubes are used to balance rotor load, replace the glass balance tube every ten cycles to prevent possible breakage caused by the repeated stress of centrifugation. Replace the tube inserts immediately if a tube breaks during centrifugation.

- 4 Close and latch the centrifuge cover.
 - 5 Select the spin time by pressing a cycle time button.
 - 6 Press **Start** button.
-

Cycle Selection

Select spin time settings to achieve optimum results for specific applications.

The following are general guidelines:

Table 5 Cycle Selection

Setting	Description	Speed	RCF
3 min	Separates plasma/serum from whole blood for chemistry and cardiac testing.	5100 rpm	4000 xg
5 min	Separates plasma/serum from whole blood for chemistry and cardiac testing. Recommended for most Greiner gel tubes	5100 rpm	4000 xg
10 min	Slower spin. Centrifugal forces are decreased to provide a conventional spin.	4500 rpm	3100 xg

Unloading



Warning

Always operate the system with shield and cover in position and secured to avoid injury.

Perform system operations with caution.

Wear Personal Protective Equipment (PPE) such as gloves, eye shields, and lab coats.

Wash hands thoroughly after contact with sample media and all maintenance activities.

Observe all laboratory policies and procedures related to the handling of biohazardous materials.

Refer to the applicable sources (such as Safety Data Sheets) for specific hazard information.

-
- 1** When the cycle completes, the rotor decelerates to a complete stop in 45 seconds or less. The instrument beeps 3 times, and the cover latch automatically releases.
-
- 2** Lift the cover.
-
- 3** Carefully remove the tubes and try not to resuspend the sample.
-

Operating Instructions

Spinning the Sample

Overview

Beckman Coulter recommends that instrument operators perform periodic inspections and preventative maintenance on all devices. Contact Beckman Coulter at any time if the instrument is not functioning correctly.

 **Caution**

Disconnect the power cord from the electrical outlet before performing maintenance or inspection.

 **Warning**

Inspect the instrument for cracks or any physical damage to housing, cover, and rotor upon the receipt of the unit. Damage can cause unsafe operation; if damage or cracks are found, discontinue use until repairs have been performed.

 **Warning**

Do not expose the rotor to strong or concentrated acids, bases, esters, aromatic or halogenated hydrocarbons, ketones, or strong oxidizing agents, or environmental influences, including natural ultra-violet radiation. Doing so will subject the rotor to corrosion or weakening of the construction.

Cleaning

Clean the outside surfaces and the control panel with a water-dampened absorbent tissue and mild detergent. Clean the inner surface with a mild detergent and if necessary, a disinfectant, wiping with an absorbent tissue dampened with 70% alcohol or 10% bleach solution.

 **Caution**

Do not spray cleaning solutions directly onto the centrifuge bowl or housing. Overspray can reach the motor bearings or internal circuitry, causing harm to the electronics and could also cause corrosion or weakening of the construction of the protective casing.

Before using any cleaning or decontamination methods other than those recommended by the manufacturer, users should check with the manufacturer that the proposed method will not damage the equipment. Cleaning and decontamination

Maintenance

Checking the Rotor Speed

may be necessary as a safeguard before laboratory centrifuges, rotors, and any accessories are maintained, repaired, or transferred.

General Cleaning

- 1 Open centrifuge cover.
- 2 Turn off the power and unplug the power cord from the electrical outlet.
- 3 Remove the shield.
- 4 Remove the rotor (For more information, refer to [Removing and Installing the Rotor.](#))
- 5 Clean bowl area with mild detergent.
- 6 Re-install rotor (For more information, refer to [Reinstalling the Rotor.](#))
- 7 Plug the power cord into the electrical outlet.

Disinfecting the Rotor

- 1 Open centrifuge cover.
- 2 Turn off the power and unplug the power cord from the electrical outlet.
- 3 Remove shield to allow access to the rotor.
- 4 Remove the rotor. (For more information, refer to [Removing and Installing the Rotor.](#))
- 5 The rotor and inserts may be soaked in detergent and warm water or a 10% bleach solution.
- 6 Do not attempt to clean an insert that has a broken tube. Dispose of insert immediately.
- 7 Dry the rotor and inserts with a clean absorbent paper towel or allow to air dry.
- 8 Re-install the rotor. (For more information, refer to [Reinstalling the Rotor.](#))
- 9 Plug the power cord into the electrical outlet.

Checking the Rotor Speed

The rated speeds can be checked with a stroboscope or photoelectric tachometer. Point the tachometer through the transparent cover at the reflective patch located near rotor center. Do not defeat any safety interlocks while performing the test. If the StatSpin Express 4 fails

to achieve an operating speed of 5,100 rpm \pm 5% in the 3 minute and 5 minute settings or 4,500 rpm \pm 5% in the 10 minute setting, contact Beckman Coulter.

Inspecting the Rotor

To inspect the rotor for cracks or damage monthly:

- 1 Clean and dry the rotor. For more information, refer to [Cleaning](#).
 - 2 Hold the rotor under a light source.
 - 3 Tilt and slowly rotate the rotor to inspect for hairline cracks on the rotor plate.
 - 4 Inspect the rotor for cracks or damage. Discontinue use of centrifuge if any cracks are found and replace the rotor. Contact Beckman Coulter at any time if the instrument is not functioning correctly.
-

Periodic Maintenance Check

When the cycle counter in the instrument reaches 50,000 run cycles, the Error or Service indicator will continuously illuminate. The indicator is a reminder to perform some important maintenance inspections on the instrument. Follow these steps to complete the maintenance inspection and reset the cycle counter.

Replace damaged or cracked components found during the inspection immediately. Contact Beckman Coulter to order replacement parts or to schedule a repair.

- 1 Open the cover.
- 2 Turn off the power and unplug the power cord from the electrical outlet.
- 3 Remove protective shield and rotor from the instrument. For more information, refer to [Removing and Installing the Rotor](#).
- 4 Clean the inside surfaces of the shield and bowl, as well as the rotor, with a mild detergent.
- 5 Inspect the cover and housing for any cracks – particularly around the hinge area.
- 6 Inspect the cover gasket for tears and excessive flattening.
- 7 Inspect the latch guide (black) on the front of the housing for cracks.
- 8 Inspect the keypad for cracks or worn areas.

Maintenance

Troubleshooting

-
- 9 Inspect the rotor for cracks, warping, or loose hardware. For more information, refer to [Inspecting the Rotor](#).

Do not reinstall the rotor if any are discovered.

-
- 10 Re-install the rotor and protective shield into the instrument.
-

Resetting the Cycle Counter



Warning

Only reset the cycle counter after conducting the recommended inspections and service. Resetting the cycle counter without performing the recommended inspections and service reduces the reliability and safety of the instrument.

-
- 1 Hold down the 3 and 5 minute cycle buttons while powering the unit on. The instrument beeps continuously.
 - 2 Release the buttons. The beep stops. The cycle-counter resets to zero.
 - 3 Run a test cycle to confirm that the red Error or Service indicator is not lit.
-

Troubleshooting

Table 6 Troubleshooting

Symptom:	Solution:
Red Error or Service indicator flashing.	Refer to Error Code Table of manual to identify and correct problem.
Tubes are loose and do not fit into buckets.	Be sure the correct tube inserts are in use. Inspect insert listing available under accessories to match with appropriate tube sizes
No LEDs are on and unit does not spin.	Main power switch is located on rear panel along with fuse holder. Inspect the switch position and condition of the fuses. Confirm power cord is plugged into a powered outlet.
Unit vibrated and shuts down.	The centrifuge detected an imbalance and stopped operation. Clear the error using the keypad and inspect the balance tube to ensure the same size and style tubes in the opposite positions. The liquid in the balance tube should be at the same level as the sample tube (refer to Spinning the Sample). The weight difference between the tubes should be less than 4 grams. If the correct balance is being used, then inspect the rotor for any wear or damage. Follow the instructions on how to inspect the rotor. Remove rotor and inspect for cracks, warping, or loose hardware. If any are found, discontinue operation and contact Beckman Coulter Customer Service for rotor replacement.
A crack in the top cover or housing.	Discontinue operation. Have unit serviced.

Table 6 Troubleshooting (Continued)

Symptom:	Solution:
Rotor does not come off motor shaft.	Remove the screw and apply a straight upward pressure at rotor center. For more information, contact Beckman Coulter Customer Service.
Red Error LED is on and does not turn off.	The cycle counter has reached 50,000 run cycles. Please perform the periodic maintenance checks as indicated in Section 4.
Caps are popping off the tubes during centrifugation.	Be sure the correct tube inserts are in use. Inspect insert listing available under accessories to match with appropriate tube sizes.
Sample is not separating adequately.	Be sure the tubes are correctly mixed immediately following collection. Refer to tube manufacturer for recommended procedure. Inspect rotor speed and cycle times. Allow serum tubes to clot before centrifugation.
Tubes are breaking during centrifugation.	Replace the tube insert. Do not attempt to clean broken glass from inserts. If glass tubes are used as balance tubes, they should be replaced after 10 cycles.
Cover does not open.	Confirm unit has power; press the Stop or Open button. If there is a power failure or malfunction, insert the manual latch release tool into the small hole on front panel. The cover releases and samples can be removed.
3 minute, 5 minute, 10 minute flashing, unit does not spin.	Confirm shield is securely locked in position (counter-clockwise).

Replacing the Fuse



Caution

Disconnect the power cord from the electrical outlet before performing maintenance or inspection.



Caution

Ensure to replace the fuse with the correct type and rating for continued protection against risk of fire and/or improper instrument operation.



Caution

If the fuse continues to blow after being replaced, contact service for additional assistance.

Items required:

- #2 flat head screwdriver
- Replacement fuse (as required)

To replace the fuse:

Maintenance

Service

-
- 1** Turn off the instrument power and disconnect the power cord from the instrument.

 - 2** Use the flat head screwdriver to remove the fuse block located below the ON/OFF switch.

 - 3** Replace the fuse: 5x20 mm type, rated F2.5A, 250V.

 - 4** Reinstall the fuse block and reconnect the power cord.

Service

Refer all service to qualified service personnel or Contact Beckman Coulter Customer Service at 1-800-854-3633.

Be sure to complete and return the warranty card as directed.

Decontamination before returning for service:

Any instrument or accessory containing accumulated blood or other biological or chemical deposits must be cleaned before shipment for service. This decontamination is required by Federal Law (Title 48 and 49 of the Federal Regulations) and according to the Environmental Protection Agency's Regulations for Biohazard Waste Management. Beckman Coulter cannot perform decontamination.

APPENDIX A
Specifications

Specifications

Product Number	SSH4
Model Number	M510
Spin Parameters	3 minutes: 180 seconds at 5100 rpm, 4000 xg
	5 minutes: 300 seconds at 5100 rpm, 4000 xg
	10 minutes: 600 seconds at 4500 rpm, 3100 xg
Acceleration Time	≤30 seconds
Deceleration Time	≤30 seconds
Electrical	100 to 240 VAC, 50/60Hz, 2.5 Amps
Dimensions	Height: 8.0 inches (20.3 cm)
	Width: 13.0 inches (33.0 cm)
	Depth: 16.0 inches (40.6 cm)
	Weight: 20 lbs. (9 Kg)
Environmental	Indoor use only
	Operating temperature: 2°C to 40°C
	Storage temperature: -10°C to 50°C
	Maximum 80% RH between 2°C to 30°C, decreasing to 50% RH at 40°C
	Maximum altitude 2000 m
	Main supply voltage fluctuations not to exceed ±10% of the nominal voltage
	Transient over-voltages according to installation category II
	Pollution degree 2

Specifications

Specifications

References

1. CLSI. *Protection of Laboratory Workers from Occupationally Acquired Infections; Approved Guideline-Third Edition*. "CLSI document M29-A3 [ISBN 1-56238-567-4]. CLSI, 940 West Valley Rd, Suite 1400, Wayne, Pennsylvania 19087-1898 USA, 2005.
2. CDC. *Recommendations for Prevention of HIV Transmission in Health Care Settings*. MMWR (Suppl. No. 2S):2S-18S, 1987.
3. CDC. Updated: *US Public Health Service Guidelines for the Management of Occupational Exposures to HBV, HCV and HIV and Recommendations for Post Exposure Prophylaxis*. Appendix A and B. MMWR 50 (RR-11): 1-42, June 29, 2001.

References

References

www.beckmancoulter.com



© 2025 Beckman Coulter, Inc.
All Rights Reserved.